

GasTurb 13



GasTurb 13

Design and Off-Design Performance of Gas Turbines

GasTurb GmbH

GasTurb 13

Copyright © 2018 by GasTurb GmbH

All rights reserved. No parts of this work may be reproduced in any form or by any means - graphic, electronic, or mechanical, including photocopying, recording, taping, or information storage and retrieval systems - without the written permission of the publisher.

Products that are referred to in this document may be either trademarks and/or registered trademarks of the respective owners. The publisher and the author make no claim to these trademarks.

While every precaution has been taken in the preparation of this document, the publisher and the author assume no responsibility for errors or omissions, or for damages resulting from the use of information contained in this document or from the use of programs and source code that may accompany it. In no event shall the publisher and the author be liable for any loss of profit or any other commercial damage caused or alleged to have been caused directly or indirectly by this document.

Printed in Germany

Table of Contents

Foreword

Part I Getting Started 1

1 Introduction 2

Program Requirements and Installation 2

 License software..... 3

Getting Help 3

 Support & Updates..... 3

 Tutorials 4

What's New 4

Compatibility with Previous GasTurb Versions 4

 GasTurb 12 (and earlier versions)..... 4

 GasTurb 11 (and earlier versions)..... 5

 GasTurb 10 (and earlier versions)..... 7

2 First Steps 7

Program Scope 7

Engine Configurations 8

Starting the Calculation 9

Define Composed Values 10

Define Iterations 12

Switching Between SI and Imperial Units 13

3 More Cycle Design Calculations 13

Parametric Studies 13

Optimization 15

Monte Carlo Study 17

Effects of Small Changes 19

4 Off-Design Calculations 20

Input Data For Off-Design Simulations 20

Variable Compressor Geometry 21

Maximum and Minimum Limiters 22

Automatic Bleed 24

Single Operating Line 24

Multiple Operating Lines 25

Off-Design Parametric Study 26

Mission Calculations 26

Effect of Small Changes in Off-Design 27

Flight Envelope 28

Off-Design Monte Carlo Study 28

Transient 28

Test Analysis by Synthesis 31

5 More than Performance 32

Part II The Cycle Design Point 35

1 Input Data 36

Basic Data 36

Secondary Air System 37

Ambient Conditions 39

Mass Flow 40

Compressor Efficiency 40

Turbine Efficiency 41

Conventional Test Analysis 42



- Test Analysis Example 43
- Reheat 44
- Nozzle 45
 - Convergent Nozzle..... 45
 - Convergent Divergent Nozzle..... 45
 - Nozzle Calculation Switch..... 46
- Thermodynamic Stations 46
- 2 Parametric Studies 47**
 - Parametric Study with Iteration 48
 - Companions 49
 - Contours and Boundaries 50
 - Picture Overlay 51
 - Combining Design and Off-Design Results 52
 - Difference Between Two Parametric Studies 53
- 3 Cycle Optimization 54**
 - Optimization Variables 55
 - Constraints 55
 - Off-Design Constraints 56
 - Figure of Merit 56
- 4 Sensitivity Studies 56**
- 5 Monte Carlo Study 56**
 - Engine Design Uncertainty 56
 - Test Analysis Uncertainty 57
- 6 External Load 58**
 - Power Offtake from Any Spool 58
 - Lift Fan 58
 - Load Compressor 59
- Part III Geometrical Engine Design 61**
 - 1 Overview 62**
 - 2 Engine Design Example 63**
 - 3 Flow Annulus 63**
 - Compressors 63
 - Turbines 65
 - Other Components 66
 - 4 Disk Design 66**
- Part IV Off-Design Performance 69**
 - 1 General 70**
 - Data Files 70**
 - Standard Data Files..... 70
 - Engine Model Files..... 70
 - Map Scaling File..... 71
 - Compressor Maps 71**
 - Map Scaling Procedure..... 71
 - Standard Maps..... 71
 - Selected Maps..... 71
 - Special Maps..... 72
 - Efficiency Scaling..... 74
 - Map Scaling Example..... 75
 - Another Map Scaling Example..... 76
 - Use of Unscaled Compressor Maps..... 76
 - Single Stage Fan Map Scaling..... 77

Turbine Maps	80
Turbine Map Scaling.....	80
Selected Maps.....	80
2 Input Data for Steady State	81
ZNX or T4 Given	82
Con/Di Nozzle Area Schedule	82
Iteration Variables	83
Inlet Flow Distortion	83
Off-Design Turbine Tip Clearance Correction	84
Modifiers	84
Variable Geometry (Compressor)	85
3 Operating Line	86
General	86
Single Spool Turboshaft	87
Operation with Variable Spool Speed.....	87
Operation with Constant Spool Speed.....	87
Reheat	88
Off-Design Parametric Study	88
4 Calculating a Series of Points (Mission)	89
Mission List Output	90
Output Used as Input	91
Export of Results	92
5 Effect of Small Changes	92
6 Flight Envelope	93
7 Calibrating a Model	96
Test Data	96
Test Data File Format	96
Data Enrichment	97
8 Monte Carlo Simulations	99
Manufacturing Tolerance	99
Engine Test with Control System Interaction	99
9 Model Based Test Analysis	100
Turbojet Testbed	100
Turboshaft Testbed	101
Compressor Performance Analysis	101
Single Point Data Input	102
Turbine Capacity	103
Test Vehicle Air System	103
Flow Analysis Method	103
Deviations from Model	104
Thrust Facility Modifier	104
Multiple Point Data Input	104
Sensor Checking	105
ISA Correction	106
Schedule Correction	107
Effect of Measurement Errors	107
Comparing a Model with Measured Data	108
Data Export	108
Data Output to File.....	108
Export To Excel.....	109
10 Steady State Engine Control	109
Limiters	109
Single Limiter Settings.....	109
Limiter Schedules.....	111



- Limiter Codes..... 112
- Automatic Bleed 113**
- Thrust Management 113**
 - Fighter Engines..... 113
 - Subsonic Airliners..... 114
 - Flat Rating at Sea Level..... 115
 - Flat Rating at Altitude..... 115
 - EGT Margin..... 116
 - Thrust Setting Parameters..... 117
 - The Throttle Lever..... 118
 - Rating Availability in the Flight Envelope..... 118
 - Calculating Rating Schedules..... 119
 - Take Off Rating..... 120
 - Max Continuous Rating..... 122
 - Max Climb, Max Cruise..... 123
 - Idle 124
 - Using the Power Lever..... 125
 - Rating Adjustments 126
 - De-Rating..... 126
 - Assumed (FLEX) Temperature De-Rating..... 127
 - Flight Idle and Ground Idle..... 128
 - Cruise and Partload..... 128

- 11 Transient 128**
- Simplified Model 128**
- Enhanced Model 129**
 - Tip Clearance..... 130
 - Heat Soakage..... 131
 - Compressor and Turbine..... 132
 - Burner 133
- Transient Control 133**
 - Power Lever Definition..... 133
 - Acceleration and Deceleration Control..... 133
 - Limiter Codes..... 133
 - PID Control..... 136
- Input Data for Transient 136**
 - General..... 137
 - Burner Time Constant..... 137
 - Temperature Sensor Time Constant..... 137
 - 100% Power Offtake and Bleed..... 137
 - Enhanced Model..... 138
- Time Dependent Input 138**
 - Power Lever Movement..... 138
 - Spool Speed..... 139
 - Fuel Flow..... 139
- Running a Transient 139**
 - Simplified Model..... 139
 - Enhanced Model..... 140
- Part V Component Modeling 141**
- 1 Gas Properties 142**
 - Air and Combustion Gases 142**
 - Fuel 142**
 - Humidity 142**
 - Inlet Fogging 143**
 - Water and Steam Injection 143**
 - Standard Atmosphere 144**

2 Component Map Format	145
Intake Map	146
Compressor Map	146
Reynolds Correction	148
Reynolds Number Index	148
Efficiency and Mass Flow Correction	150
Pipe Flow Analogy	150
Application of the Pipe Flow Analogy	152
Variations of the Pipe Flow Analogy	153
Propeller Map	153
Turbine Map	154
Smooth C and Smooth T	154
3 Intake	155
Flight, Test Bed and Power Generation Input Mode	155
Pressure Loss	155
Altitude Test Facility	156
Inlet and Exhaust Pressure Losses for Power Generation	157
4 Compressor	157
Compressor Design	157
Compressor Calculation	158
Compressor Efficiency Estimates	159
Recirculating Bleed	160
Wet Compression	160
Work done on Liquid Water	161
Inlet Flow Distortion	162
Parallel Compressor Theory	162
Compressor Coupling	164
Pressure Distortion	164
Temperature Distortion	165
5 Gearbox	165
6 Duct Pressure Losses	165
7 Intercooler	166
8 Heat Exchanger	166
Simulation Options	166
Bypass Valve	167
9 Combustor	167
Temperature Rise	167
Off-Design Efficiency	167
Pressure Losses	170
Sequential Combustion	170
Emissions	170
NOx	170
CO and HC	171
10 Turbine Design	171
Turbine Design	171
Blade Metal Temperature	172
Turbine Tip Clearance Correction	173
Blade Root Stress	173
11 Turbine Performance Calculation	174
Un-Cooled Turbine	175
Cooled Turbine	175
Thermodynamic Turbine Efficiency	176
Turbine Interduct Pressure Loss	177
12 Exhaust Duct Pressure Loss	177



- Calculated Inlet Swirl 178
- Swirl from Turbine Map 178
- 13 Mixer 179**
- 14 Reheat (Afterburner) 179**
 - Reheat Efficiency 180
 - Reheat Pressure Loss 180
- 15 Nozzle 181**
 - Convergent Nozzle 181
 - Convergent-Divergent Nozzle 181
 - Thrust Coefficient 183
- 16 Thermodynamic Stations 183**
- 17 Secondary Air System 184**
- 18 Propeller 184**
 - Ideal Propeller 184
 - Real Propeller 186
- 19 Component Maps 186**
 - Intake Map 186
 - Compressor Maps 187
 - Compressor Map 187
 - Fan Map 188
 - Single Stage Fan Map 189
 - Beta Value 190
 - Surge Margin 190
 - Turbine Map 191
 - Propeller Map 192

Part VI Engine Dimensions 193

- 1 Using a Given Cross Section 194**
- 2 Engine Inlet 196**
- 3 Fan 196**
 - Fan and Booster Design Example 197
- 4 Compressor 197**
 - Axial Compressor 197**
 - HP Compressor Design Example 199
 - Aerodynamic Design 200
 - Radial Compressor 212**
 - Conceptual Design - Radial Stage 212
 - Single Stage Geometry 214
 - Two Stage Geometry 216
- 5 Burner 216**
 - Axial Flow Burner 216**
 - Axial Flow Burner Design Example 217
 - Reverse Flow Burner 217**
 - Reverse Flow Burner Design Example 217
- 6 Turbine 218**
 - HP Turbine Design Example 218
 - LP Turbine Design Examples 219
- 7 Inter-duct 220**
- 8 Turbine Exit Duct 221**
- 9 Bypass 221**
- 10 Mixer 222**

- 11 Reheat 222
- 12 Exhaust 222
- 13 Intercooler and Heat Exchanger 224
- 14 Gearbox 224
- 15 Shaft 225
- 16 Disk Design Methodology 225
 - Geometry 225
 - Temperature 226
 - Design Options 226
 - Design Criteria 228

Part VII Combined Cycle and Cogeneration 229

- 1 Heat Recovery Steam Generator 230
 - Single Pressure 230
 - Design 231
 - Off Design 232
- 2 Steam Turbine 232

Part VIII General Options 233

- 1 Range Checking 234
- 2 Composed Values 234
 - Definition 234
 - Using Design Cp_Val's During Off-Design 236
 - General Tables 236
 - Pre-Defined Functions 237
 - Input Parameter 238
 - Userdefined Dynamic-Link Libraries (DLLs) 238
 - dll-File 239
 - ini-File 239
- 3 Iterations 241
 - Design 241
 - Off-Design 241
 - Condition 242
- 4 Export of Data 242
 - Export to Excel 242
 - User Defined File Content 243
 - Maps 244
- 5 Batch Mode 244
 - Batch Job Nomenclature 244
 - Batch Job Editing 245
 - Running a Batch Job 246
- 6 Graphics 247
 - General 247
 - Several y-Axes 248
 - Copy to Clipboard 250
 - Contour Lines 250
 - Picture Catalog 250
- 7 Options 251

Part IX Mathematics 253



1	Iteration Algorithms	254
	General Iteration Technique	254
	Numerical Example	255
	Convergence Problems	255
	Convergence Monitor	256
	Iteration Setup Examples	258
	Single Spool Turbojet	258
	Two Spool Turboshaft, Turboprop	259
	Boosted Turboshaft, Turboprop	260
	Unmixed Flow Turbofan	261
	Mixed Flow Turbofan	262
	Geared Turbofan	262
	Variable Cycle Engine	263
2	Monte Carlo Simulations	264
	Overview	264
	Statistical Background	264
	Symmetrical Distributions	265
	Asymmetric (Trapezoid) Distribution	266
3	Optimization Strategies	266
	Gradient Search	267
	Random Search	269
Part X How to ...		271
1	... Adjust the Cycle Design Point	272
2	... Adjust the Off-Design Model	272
3	... Modify the Efficiency Distribution in a Compressor Map	273
4	... Re-Label the Speed Lines in a Compressor Map	274
5	... Set the Design Points in the Component Maps	275
6	... Model a Derivative Engine	276
7	... Compare Data with GasTurb Results	278
8	... Calculate Off-Design Performance for Specified Thrust or Fuel Flow	278
9	... Modify Reynolds Number Corrections	279
10	... Increase Surge Margin	279
11	... Use a Booster Map with an Unmixed Turbofan	280
12	... Select the Optimum Fan Pressure Ratio for Turbofan Engines	280
13	... Make a Turbine Temperature Schedule	281
14	... Make Nozzle Area a Function of Corrected Speed	281
15	... Estimate the Confidence of Achieving the Development Target	282
16	... Analyse a Transient Test	283
17	... Simulate Water Injection into a Turbofan	283
18	... Generate Data for Input to Aircraft Performance Calculation Programs	34
19	... Design an Engine for a Supersonic Aircraft	284
20	... Investigate a Variable Cycle Engine	287
21	... Speed up the Calculation	287
22	... Compare Temperature-Entropy and Enthalpy-Entropy Diagrams	287
23	... Recover from a "General Error"	288
24	... Compile the Program	288

Part XI Nomenclature and Units	291
1 File Nomenclature	293
2 Station Designation	293
3 Symbols	294
4 Short and Long Names	296
5 Units	296
6 Total Pressure	297
7 Total Temperature	297
8 Further Definitions	298
GasTurb Deck	298
Heat Rate	298
Stator Outlet Temperature	298
Rotor Inlet Temperature	298
Standard Day Conditions	298
Spool Speed	299
Corrected Flow	299
Aircraft Speed	300
Entropy Function	300
Exergy	301
Relative Enthalpy Rise	302
Equivalent Shaft Power	302
Turbine Flow Capacity	302
Heat Exchange Effectiveness	303
AnSyn Factor	303
Propulsive Efficiency	304
Thermal Efficiency	304
Core Efficiency	304
Transmission Efficiency	305
Overall Efficiency	305
Peak Efficiency	306
Part XII Acknowledgements	307
Part XIII References	309
Index	315

Foreword

GasTurb is a powerful and flexible gas turbine cycle program and it is accompanied with additional tools, namely **Smooth C**, **Smooth T**, **Map Collection** and **GasTurb Details**. Dr. Joachim Kurzke is the inventor and developer of these programs. Having been a performance engineer of MTU Aero Engines for 28 years and one of the most respected performance experts in the world, he has built this program package which gives a thorough insight into gas turbine performance theory while being easy to operate. He has closed the gap between the complexity of the matter and ease of program use by building in his expert knowledge through pre-defined performance tasks with an exceptionally intuitive graphical user guidance. Furthermore Dr. Kurzke has outlined in detail his physical modeling in manuals to all programs. Most valuably, he and his co-author Ian Halliwell complemented the GasTurb programs with their book "Propulsion and Power - An Exploration of Gas Turbine Performance Modeling", published in 2018, within which they use practical examples to guide the user through principal and more sophisticated performance tasks.

In 2013 the program development responsibility was transferred to the company GasTurb GmbH in Aachen, Germany. Since then a team of performance engineers sustains, maintains and extends the features of the programs. The RWTH-Aachen University and Professor Peter Jeschke's Institute of Jet Propulsion and Turbomachinery are strategic partners of the GasTurb GmbH.

GasTurb

- is a program for calculating design and off-design performance of gas turbines
- simulates the most common types of aircraft and power generation gas turbines
- helps with parametric studies, calculates exchange rates, does Monte Carlo studies and offers numerical optimization
- shows engine cross sections with station numbering and air system
- provides temperature-entropy, enthalpy-entropy, and pressure-volume diagrams
- takes additional user specified correlations into account, which can be given as formulae or tabulations
- calculates a combined cycle with gas turbine, heat recovery steam generator, steam turbine and condenser
- uses component maps for off-design
- defines a mission based on many operating conditions or a flight envelope and calculates all points in a single run
- simulates the transient operation of gas turbines
- models the thrust management of commercial airliners
- simulates engine deterioration
- performs model based test analysis and engine performance monitoring
- can run in batch mode and export results to Microsoft Excel
- does preliminary engine design and draws the general arrangement to scale
- estimates weights for each engine configuration
- includes stress calculation for disks and optimization of their shape

New Features in **GasTurb 13**:

- improved map selection for more realistic off-design calculations (e.g. offering to choose between subsonic and transonic booster maps, single or multi-stage fans)
- compressor aerodynamic design, based on mean line analysis of multi-stage compressors, including optimization and generation of cross-sectional drawings
- improved graphics, new plot options, and a carefully optimized user interface with modern icons
- enhanced computational speed and many further improvements (find out more on <http://download.gasturb.de/NewInGasTurb13.pdf>)

The **GasTurb 13 Laboratory Package** includes the following additional tools for the advanced user, which are described in separate manuals.

Smooth C and Smooth T among others ...

- quickly produce high quality compressor or turbine maps from measured data
- create maps for performance software like GasTurb, NPSS, PROOSIS
- can be used to extract maps from literature and compare different maps
- offer many cross plots to check whether the map is a reasonable description of underlying physics
- allow physical meaningful interpolation and extrapolation of maps

Map Collection among others ...

- contains 58 compressor maps and 15 turbine maps from open literature
- offers digitized maps ready for use with GasTurb and Smooth C / Smooth T

GasTurb Details among others ...

- allows doing basic calculations with the same procedures as used in GasTurb
- isolates single components of the engine to allow in-depth analysis independently of GasTurb
- includes basic thermodynamic and aerodynamic calculations
- can be used as a slide ruler specialized for gas turbine problems

More information is found on the GasTurb website <http://www.gasturb.de>.

Dr. Joachim Kurzke is the principal author of the GasTurb software and this manual. Most of the new features in GasTurb 13 are based on his ideas. Corresponding chapters in the manual have been added by the team of GasTurb GmbH. A significant addition is the mean line design feature for axial compressors which has been developed and implemented by the team of GasTurb GmbH.

The GasTurb Team

Getting Started





1 Getting Started

1.1 Introduction

Welcome to GasTurb 13, a program which makes it easy to evaluate the design and off-design performance of the most common types of gas turbines.

1.1.1 Program Requirements and Installation

Requirements

For running GasTurb 13, you need a PC running a Microsoft Windows operating system (Windows 2000, XP, Vista, 7/8/10). The license server, used for Floating and Site Licenses, can run on Windows, Max OS, Linux or Solaris.

Installation

Run setup for installing the program. A wizard will lead you through the details of the installation.

Install GasTurb 13 in its own, new directory and do not install it in the directory of any previous program version you may have. Some of the files delivered with GasTurb 13 have the same file name as those of previous versions, but different file contents. Mixing the files from different versions of GasTurb will cause a program crash.

Installation on a Network

On a network you can store the program in a directory which everybody can access. The various users should store their private data in their own directories for data and component maps. Note that the component maps delivered with the program must reside in the same directory as the program. You can store a copy of these files in a private component map directory. The component map collection which is part of GasTurb 13 Laboratory needs not be in the program directory, it can reside in any directory.

A Microsoft security measure prevents HTML Help .CHM files from being opened on network drives. When you call help, "Action canceled!" will be displayed instead of the topic text. This will happen with all HTML Help files that you open over a network connection (note, that local HTML Help files will not be affected). The reason for this error is a new and more strict security policy for Microsoft Internet Explorer.

When you install the program on a network, please ensure that the help file (file extension .CHM) gets installed on the local C: drive (this is recommended by Microsoft). If this is not possible or not desirable, you can explicitly register individual help files and folders to allow viewing them over the network or edit the Windows registry to make the security settings less strict in general. Microsoft describes the necessary steps in detail in the knowledge base article KB 896054.

Using Data Directories and Component Map Directories

If you want to store your data files and component map files in directories different from those selected automatically, you need to start GasTurb 13 with two command line parameters. Add after the program call (separated by a space) first the path to your data (this will be the standard data directory) and second the path to your component maps, the standard map directory. The working directory which you specify from Windows Program Manager as a program item property must be the directory in which the program resides.

If you have stored the program in directory C:\Programs\GasTurb (your program directory), and want your data stored in directory C:\GasTurb\Data (your standard data directory) and your component

maps in C:\GasTurb\Maps (your standard map directory) then you must start the program by the following command sequence:

```
C:\Programs\GasTurb 13.exe C:\GasTurb\Data C:\GasTurb\Maps
```

When your file names or directory names contain blanks, then you must include the path names in double quotes:

```
"C:\Program Files\GasTurb 13.exe" "C:\My Data\GasTurb\Data" "C:\My Data\GasTurb\Maps"
```

About GasTurb Files

There are some ASCII files with the extension NMS delivered with the program. Do not modify these files because they are essential for the correct interpretation of the data. Note that the *.NMS files are not compatible between the different program versions.

There are many graphic files that contain engine configuration schemes and other pictures. They are stored as Windows meta files with the extension WMF. Many other programs can read this file format. You may use these files for illustrations in reports, for example. If you do that, you must refer to the source of the graphics and include the GasTurb 13 program as a reference.

1.1.1.1 License software

Additionally to GasTurb 13, you have to install a license software called CodeMeter Control Center. This will be done automatically, if you check the respective box during the setup of GasTurb 13.

Moreover, in case you have a Floating or Site License, a license server has to be installed somewhere in your local network. Details about the installation of the license server and the activation of licenses can be found in a guide you have received together with your license information via email.

If you experience any kind of problems during the installation, please contact the [support](#).

1.1.2 Getting Help

Help can be selected from many menus. Use the help *Contents* list to find structured information, look at the *Index* or use *Find* when you need help for a specific topic.

For a short info about the meaning of a button hold your mouse pointer on it and you will get a hint about which action will be initiated by pressing this button. Note that - depending on the context of the simulation task - some of the buttons can be temporarily dimmed which indicates that they are disabled.

1.1.2.1 Support & Updates

For questions regarding installation and use of our software, all license holders can use our free email support. Our support team will help you as fast as possible.

If you suspect a bug or experience difficulties using GasTurb or its associated software, please let us know. Likewise, feel free to share your improvement ideas. All known bugs are fixed within a reasonable amount of time and bug fixes are made available. You can always download the latest service update from the [support section](#) of our website.



1.1.2.2 Tutorials

Free tutorials are available for GasTurb 13. They cover the most important functions of the software as well as more elaborate ones. The list of tutorials dealing with more advanced topics is constantly being added to. Visit the [tutorial section](#) of our website and learn how GasTurb 13 can be put into practical use.

1.1.3 What's New

There are many improvements compared to previous versions of GasTurb, both in the user interface and the technical content.

1.1.4 Compatibility with Previous GasTurb Versions

When reading a data file which has been created with a previous version of GasTurb then some warning messages may appear. These messages regard input properties that did not exist in the older program version or that have been renamed. In many cases the missing data can be set to reasonable default values, however, in some cases no generally applicable default value exists and in such a case the dummy value 111111 is introduced.

Enter a suitable number for the missing data that are indicated by the dummy number 111111. Commencing the calculation while one or more properties have the dummy value 111111 will result in an error message. Writing the completed data file to disk by GasTurb 13 will make the data set compatible with the new version.

Reading a data set from a previous version of GasTurb and calculating the geometry of the engine with the default settings which the program uses for the missing data frequently does not yield a reasonable engine geometry. This applies also to the demo data sets from previous GasTurb versions; therefore a number of new demo data sets have been created that yield nice and meaningful engine cross-sections.

1.1.4.1 GasTurb 12 (and earlier versions)

Geared Turbofan Geometry

The bypass strut geometry calculation has been modified to give a realistic transfer of momentum from the fan bearing to the casing. To the same end, an additional strut has been introduced at the booster inlet. The geometry of these features is controlled by means of the fan properties *Bypass Gap/Chord Ratio*, *Core Exit Vane Gap/Chord Ratio* and *Core Exit Duct Radius Ratio*.

Fan Geometry

With GasTurb 13, the bypass geometry calculation has been adjusted. Changing the *Bypass Inlet Mach Number M_{13}* does not affect the inner bypass inlet geometry anymore. This radius is constant. Station 13 is now defined at the outer strut exit and therefore no part of the strut is in the bypass. This changed geometry calculation also affects the mass numbers, which will hence not be identical to those calculated with earlier versions.

Radial Compressor Geometry

When using combined axial/radial compressors, an optional duct between the axial and radial stages has been introduced. This duct is invoked by selecting a value for *Duct Length/Inlet Inner Radius*.

The calculation of the last stage height of radial compressors has been modified to represent a correct relationship between length, height and aspect ratio. This may also change component masses.

Reverse Burner Geometry

An error in the mass calculation of reverse burners has been corrected. This only affects reverse burners of machines featuring radial compressors.

Reynolds Correction

In GasTurb 13, the laminar flow region is specifically considered during [Reynolds Number Correction](#). This was not the case in earlier versions. Therefore under certain inlet conditions, the off-design results may deviate.

2-Spool Turbojet

The reheat liner cooling of two spool turbojets has been modified. The cooling air is now taken directly from the fan and can be prescribed as *Liner Cooling Air Wcl/W16* (part of the *Secondary Air System*). In earlier versions, the cooling air was taken from the turbine exhaust gas and defined as *Nozzle Cooling Air Wcl/W6*.

Miscellaneous

In disk design and strain calculations, there was a bug. Under certain circumstances the temperature curves were calculated incorrectly with US units. This bug has been removed.

Calculation of cooling effectiveness and first rotor metal blade temperature in a multi-stage turbine were improved. This has only an impact on these two values but does not affect the cycle or any other value.

1.1.4.2 GasTurb 11 (and earlier versions)

In addition to the changes mentioned above, the following applies:

Secondary Air System

In GasTurb 11 and previous versions the cooling air input was from principle for a single stage turbine only. The NGV cooling air does work in the turbine and the rotor cooling air does not.

If a multistage turbines had to be simulated, then the true amounts of the various NGV and rotor cooling air streams could not directly be used as input. For each of the cooling air streams it had to be decided first to which percentage they do work in the turbine. Cooling air doing work had to be treated formally as the NGV cooling air and the not working cooling air as rotor cooling air of an equivalent single stage turbine.

The cumbersome calculation of the working and non-working fractions of the cooling air of a multistage turbine has been simplified in GasTurb 12. Now there are four input properties:



NGV 1 Cooling Air / W25	does work in all rotors
Rotor 1 Cooling Air / W25	does work in all rotors except rotor 1
NGV 2 Cooling Air / W25	does work in all rotors downstream of rotor 1
Rotor 2 Cooling Air / W25	does work in all rotors downstream of rotor 2

For calculating the working and non-working cooling air fractions the number of turbine stages needs to be known in addition to these four properties.

Property	Unit	Value	Comment
Rel. Handling Bleed to Bypass		0	
Rel. HP Leakage to Bypass		0	
Rel. Overboard Bleed W_Bld/W25		0	
Rel. Enthalpy of Overb. Bleed		1	
Recirculating Bleed W_recirc/W25		0	Off Design Input Only
Rel. Enthalpy of Recirc Bleed		1	
Number of HP Turbine Stages		1	
HPT NGV 1 Cooling Air / W25		0,05	
HPT Rotor 1 Cooling Air / W25		0,06	
HPT Cooling Air Pumping Dia	m	0	
Number of LP Turbine Stages		4	
LPT NGV 1 Cooling Air / W25		0	
LPT Rotor 1 Cooling Air / W25		0,02	
LPT NGV 2 Cooling Air / W25		0	
LPT Rotor 2 Cooling Air / W25		0	
Rel. Enth. LPT NGV Cooling Air		0,6	
Rel. Enth. of LPT Cooling Air		0,7	
Rel. HP Leakage to LPT exit		0	
Rel. Fan Overb. Bleed W_Bld/W13		0	
Core-Byp Heat Transf Effectiven		0	
Coolg Air Cooling Effectiveness		0	
Bleed Air Cooling Effectiveness		0	

Note that the number of turbine stages is needed also for the turbine efficiency calculation option and also (with calculation mode "More") for the calculation of engine geometry. Inconsistent simulations could be created if there would be three places for the input of turbine stage numbers. Therefore, from GasTurb 12 onwards, there is only one place for the input of turbine stage numbers: on the Secondary Air System page.

If you are not interested in engine geometry calculations and if you do not use the option to calculate turbine efficiency from a velocity diagram analysis, then use 1 as turbine stage number. In this case there will be no difference between the GasTurb 12 and GasTurb 11 cycle results.

For turbofan engines there are three more new input properties added at the bottom of the Secondary Air System page. They allow the simulation of heat transfer between core and bypass, [cooling the turbine cooling air](#) and a customer bleed air cooler in the bypass.

Miscellaneous

The iteration variables have been added to the mission input table. This allows using special estimates for each operating point. The price for this improvement is that mission input files created with earlier program versions cannot be read by GasTurb 12.

The calculation of equivalent shaft power for turboprop engines has been changed. Equivalent shaft power is now the power which would be delivered when expanding the gases to the exhaust pressure ratio of $P_8/P_{amb}=1$.

1.1.4.3 GasTurb 10 (and earlier versions)

In addition to the changes mentioned above, the following applies:

In the Reynolds number corrections applied during off-design simulations there was a bug: the [Reynolds Number Index](#) was calculated incorrectly. This bug has been removed and consequently in some cases the Reynolds number correction factors have changed a bit.

Inlet flow distortion simulation is now more rigorously simulated, small differences to previous results are normal. The [Coupling Factor](#) described in ASME GT2006-90419 has been introduced and the simulation option for radial distortion has been deleted.

With mixed flow engines, P_3/P_{64} in off-design simulations now a function of corrected flow W_{64R}

The rear VABI of the [Variable Cycle Engine](#) was previously either open or closed. Now it is fully variable and allows resetting the cold and hot mixer areas.

1.2 First Steps

The quickest way to familiarize yourself with GasTurb 13 is to go through this *Getting Started* section which guides you through the basics of the program using simple examples.

After completion of the tutorial you have only used a small part of the options built into GasTurb 13. Now you can have a look on the [tutorials](#) and read the manual for more detailed information on specific topics.

1.2.1 Program Scope

Three program scopes with different degrees of simulation detail are offered. Select *Basic Thermodynamics* if you have only fundamental questions, decide for *Performance* when you want to study gas turbine cycles and off-design behavior in more detail and chose *More...* if you want to do preliminary engine design.

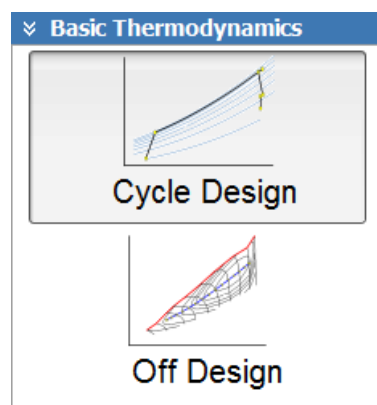

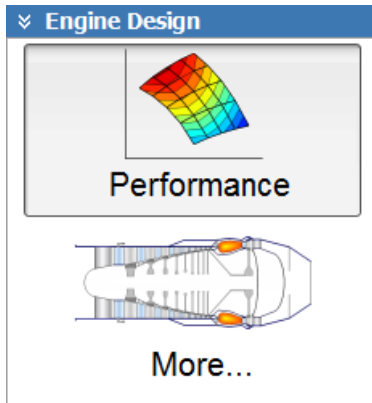

If you are interested only in the basic gas turbine cycle analysis as described in many textbooks then select Basic Thermodynamics as scope of the simulation. Then the input data are limited to the really important properties like pressure ratio, burner inlet temperature and the component efficiencies. All sophisticated details of the other two scopes are set to default values in the background. For example, all component inter-duct pressure losses are set to zero and the complex turbine cooling air system is excluded from the simulation. Thus the program input for the Basic Thermodynamics scope is very easy to take in at a glance.

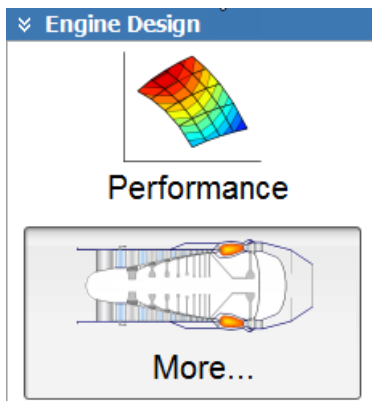

Performance is the normal operating mode for the gas turbine performance specialist. This mode adds to the basic thermodynamics the detail required for professional gas turbine performance simulations. There are more data input options, including the simulation of the secondary air system and turbine cooling. Furthermore, there are additional calculation options like cycle optimization and Monte Carlo studies, for example.



More... For the performance scope only a few dimensions of the engine are required as, for example, the nozzle area of a turbojet engine. With the scope *More..* additionally the shape and dimensions of the flow annulus are derived, compressors and turbine disks designed and a cross section of the engine is created. Thus much detail is added to the simulation and the quality of the preliminary design results is significantly improved. You will get some insight into the interaction between thermodynamics, component aerodynamics and the mechanical design of gas turbines.

After reading the input data from file you can choose in the cycle design input window to calculate the geometry of the engine, including the stresses in the disks by clicking  (*Enable Geometry*). These calculations require considerable computer power and therefore they are not pre-selected. For accessing the input data of the engine geometry select  (*Edit Geometry*).

1.2.2 Engine Configurations

Before you actually begin with calculations you must decide which type of gas turbine you want to study. The basic configuration of the engine can be selected by clicking one of the engine schematics on the *Jet Engines* or the *Gas Turbines* page. Alternatively you can choose from the configuration tree views on the *Propulsion* or the *Power Generation* page in the program main window.

If you use the engine configuration tree for selecting the basic engine type the selected engine configuration is shown as a figure to the right of the selection tree. While the selection is not yet concise enough you will see a photo with an aircraft or with power lines.

Once the basic configuration is fixed, you have additional configuration options that can be selected during engine design. For some engines you can add an afterburner (augmentor) and select between a convergent and a convergent-divergent nozzle, for example. The final selection of heat exchangers (recuperators) and intercoolers is also made in the design point input window.

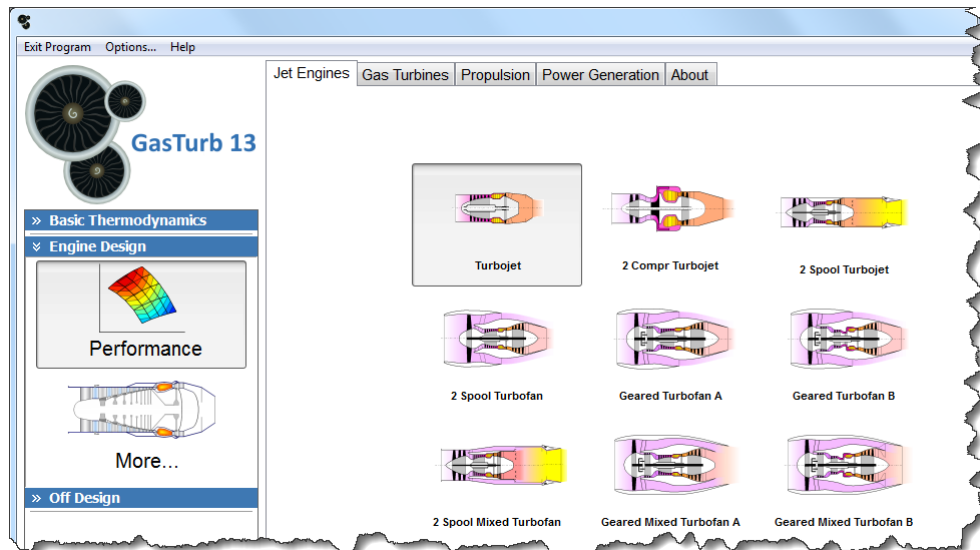

For your first tour through the program select on the Jet Engines page the TURBOJET. Click *Performance* to proceed with engine design. From the file dialog window which opens then select the file **Demo_jet.CYJ**.

1.2.3 Starting the Calculation

The cycle input data are presented in a table. The contents of this table depends on your selection in the tree view to the left of the table. The input data shown in the table are those of the selected branch in the data tree. You will not see any input quantities that are not needed for the type of calculation you have chosen. Data you have entered for a switch position not selected at the moment will not be deleted; they will just not be shown. When writing a set of data to disk, all quantities will be stored, regardless of the switch positions.

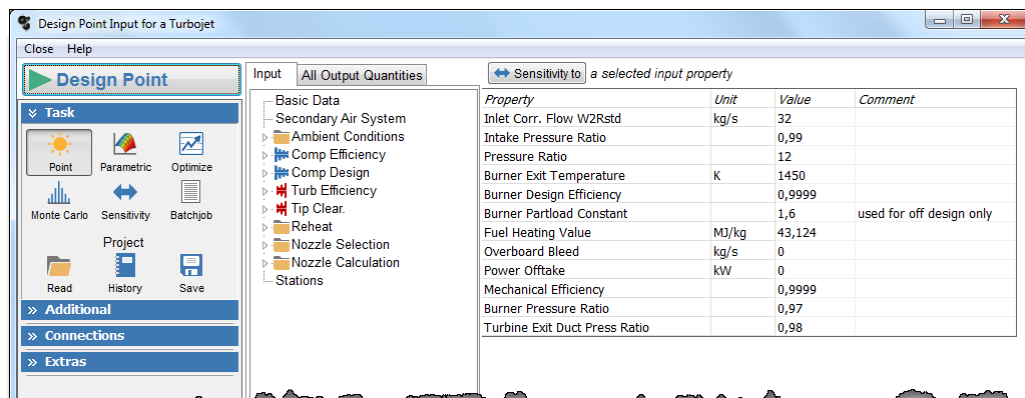

To begin the calculation click the top left button with the caption Design Point. The input data will be checked and the thermodynamic cycle calculation commences. If the result is valid, then the data will be saved automatically. For that purpose GasTurb 13 uses an automatically generated filename which depends on the selected engine configuration. Automatically saved Turbojet data files are called **Last_1_Jet.CYJ**, **Last_2_Jet.CYJ**, and **Last_3_Jet.CYJ**. Backup file names of other engine configurations also begin also with the four letters "Last".

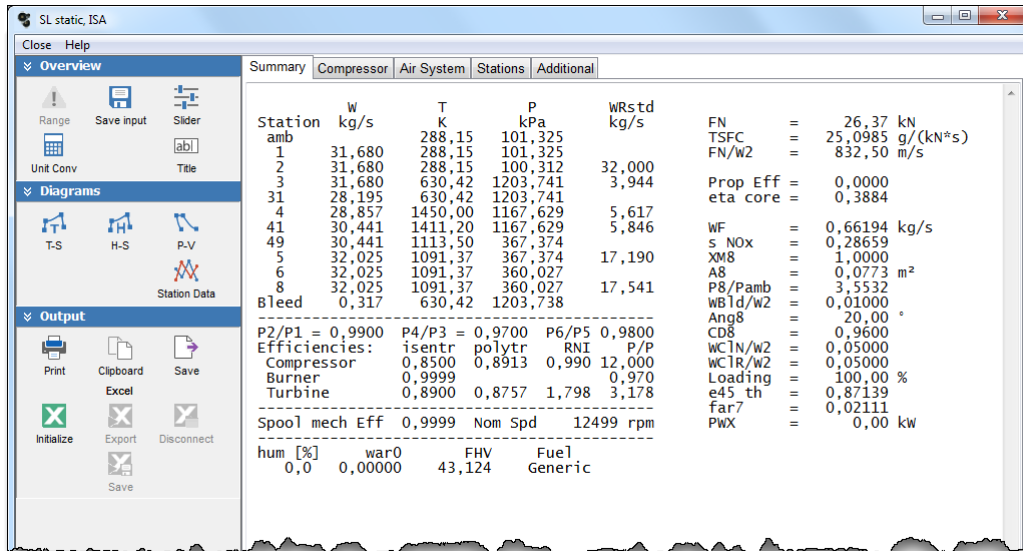

If the program fails to calculate a cycle for a specific data set, check your data for typing errors, incorrect units or wrong orders of magnitude. The program can never calculate a cycle with a burner pressure ratio of 0.04, for example. You may have entered this number because you were thinking of a burner pressure loss of 4%. GasTurb 13 tries to avoid errors caused by wrong magnitudes of input values by checking whether the value is within reasonable limits. Thus, if you really enter 0.04 as burner pressure ratio you will get a range warning.

As a newcomer to the program you should play around with the input data of the turbojet and calculate several cycles. Have a look at the cycle output window, thereby getting accustomed to the nomenclature and the units used. Note that you can get explanations for the terms used by clicking after the first letter of the name.

Use also a slider for your experiments (click (Slider) for assigning up to three variables to the slider). You can see immediately the influence of the slider variables on the cycle data.

You can mark part or all of the data, copy and paste them to your word processor or to your presentation program. If you paste the data into a Word document or to Power Point then it might happen that the text is formatted with a variable pitch font of too big a size and the printout looks like a mess. Select "Courier New" or any other fixed spaced font in appropriate size to get the data nicely arranged.

1.2.4 Define Composed Values

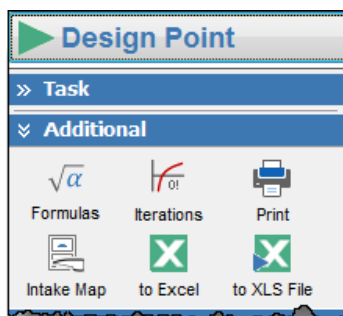

You may be interested in a quantity which is not shown in the standard output window, such as the temperature ratio across the compressor, T_3/T_2 for example. You can get the desired value by defining a composed value, click the Formulas button (in the Additional button group) for doing that.

The composed value definition window is a powerful formula editor which allows you to add your own correlations to the standard GasTurb 13 calculations. In the definition of composed values you can use any input or output property and also plain numbers. The availability of property names depends on the calculation options you have selected. If the option to calculate turbine efficiency from a velocity diagram analysis is not selected, for example, then you cannot use the geometrical data of the turbine in composed values, since they will not be calculated.

A total of 199 composed values can be defined. The mathematical operations available include +, -, *, / as well as ^ for exponential expressions. Moreover, the natural logarithm **ln(x)**, the absolute value **abs(x)** and the trigonometric functions **sin(x)**, **cos(x)**, **tan(x)**, **arcsin(x)**, **arccos(x)** and **arctan(x)** can be used in the formulae. Furthermore you can use parenthesis in your formula definitions.

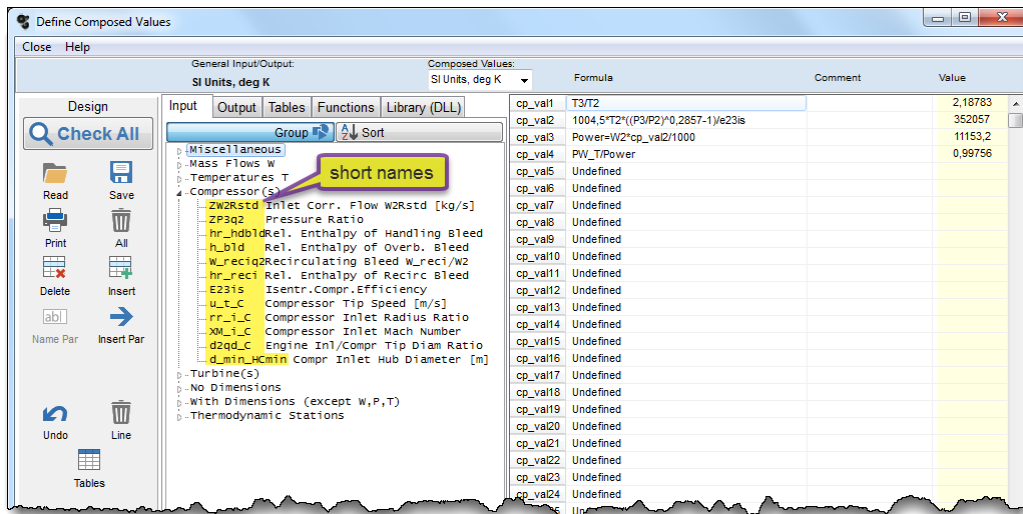

An example for a complex composed value is shown in line 2 of the composed value formula editor. For composed values you can use any previously defined composed value as you see in line 3 where the result of the formula in the second line is employed in the definition of the third composed value cp_val3.

You can give composed values a *user defined name* consisting of letters, numbers and underscores that are followed by the = sign as shown in line 3. In this example the name **Power** will be used for the text output and in the graphics. You can use the name you have introduced in further formulae as shown for example in line 4 of the screen shot above. Note that using the name **Power** in lines 1 and 2 is not permitted because the value of this property will not yet be known when cp_val1 and cp_val2 are calculated.

Note that user defined names must be different to the names that are already used as *short name* by the program. User defined names must begin with two letters and they should consist of about 4 to 8 characters. Actually, there is no restriction for the length of a user defined name, however, long names are impractical if used within other formulas. Blanks in user defined names will be eliminated by the program.

The result of an invalid operation like the square root of a negative number will be set to zero or to 999999.

Here only the most simple formulas are mentioned. The use of *tables* and *pre-defined functions* is described in later sections.



1.2.5 Define Iterations

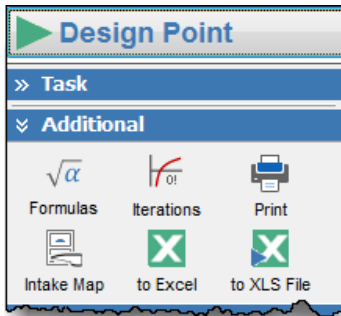

Besides using additional correlations (composed values) you can influence the calculation result by adding iterations to the standard GasTurb 13 calculation. Select this option by clicking the *Iterations* button if you want an output quantity to have a specific value. In the turbojet cycle you can, for example, iterate the compressor pressure ratio in such a way that the turbine pressure ratio will be exactly 4.0 (this could be a reasonable limit for a single stage turbine).

Whether the iteration converges or not depends very much on the problem being investigated. If there is a solution, the program will find it. Thus, check your data if you do not get convergence.

Note, that you can select up to 99 variables, thus specifying values for up to 99 output quantities. In addition to keeping the turbine pressure ratio constant, you can iterate burner exit temperature as a second variable such that the turbine exit temperature is equal to 1200K. With a third iteration you could keep the thrust constant at 40kN by iterating the engine inlet corrected flow, for example.

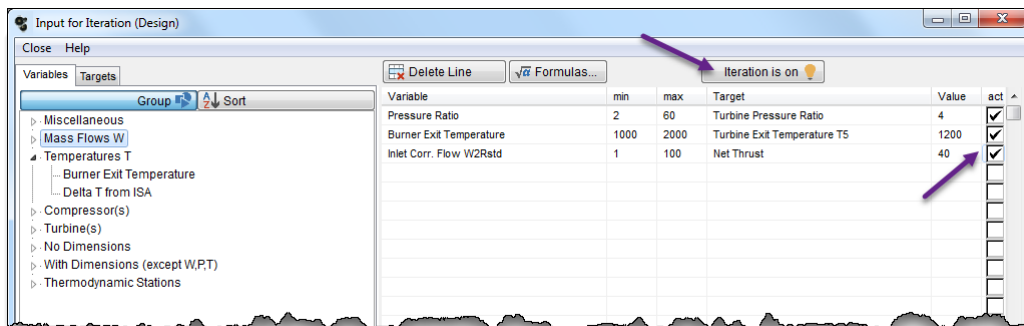

For each of the variables a reasonable range must be specified by setting **min** and **max** values. If the range is too narrow, then by accident the solution could be excluded and the iteration would fail to converge. A very wide range causes also problems, since the cycle cannot be evaluated with extreme combinations of pressure ratio and turbine inlet temperature. Moreover, a large range for the iteration variables leads to an inaccurate result.

Before closing the iteration window you must activate the individual iterations in the check boxes that are arranged along the right border of the window and in addition to that the iteration setup in general by clicking the little bulb above the table.

1.2.6 Switching Between SI and Imperial Units



In the cycle design input window click in the Extras button group the Imperial Units button to convert the input data from SI units to Imperial units. After having chosen the general system of units you can select the units for temperature from the Units page in the Options window which opens after clicking the Options button.

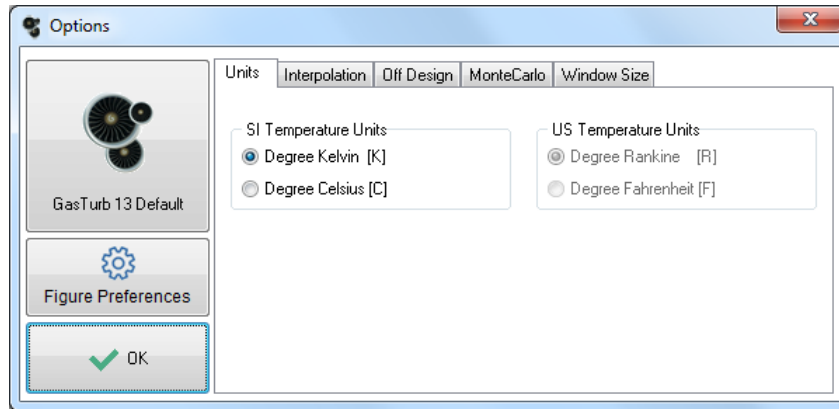

1.3 More Cycle Design Calculations

In this section of the tutorial we deal with engine design which means that each thermodynamic cycle represents a new machine. In a cycle design parametric study, for example, each calculated case yields an engine with a different geometry.

1.3.1 Parametric Studies

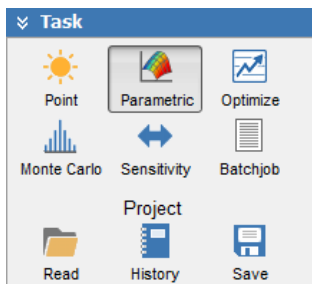

Parametric variations of one or two variables are easy with GasTurb 13. For reproducing the following example go back to the program main window and select the 2 SPOOL TURBOFAN just below the Turbojet on the Jet Engines page. Click » *Performance* and open the file **Demo_tf.CYF**. Click the  button to calculate a single cycle as a reference point.

Next click *Parametric* in the *Task* button group to go to the parameter selection window.

Select the parameters from the tree view and enter your numbers for the *Start Value*, the *Number of Values* and the *Step Size*.

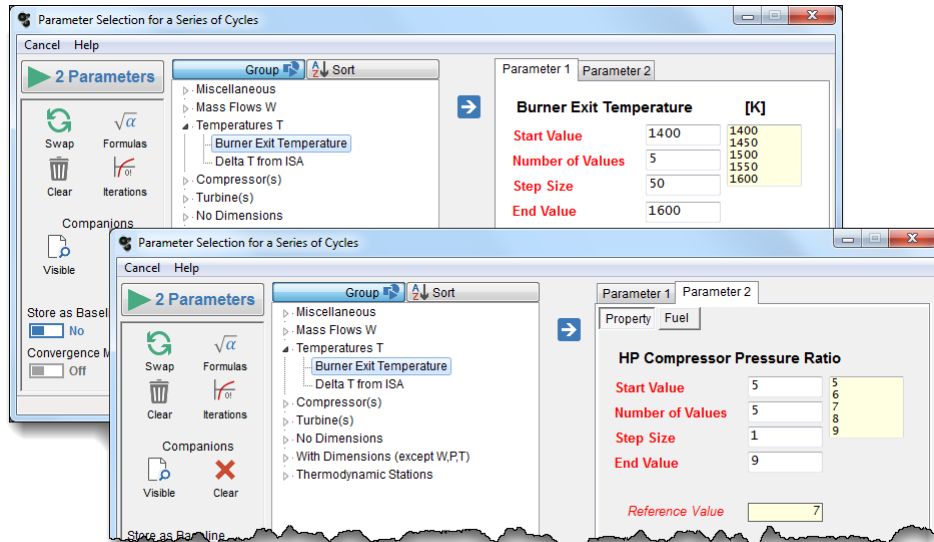

Start the parametric study by clicking the *Two Parameter* button. The calculation will be completed quickly and you can choose what you want to plot. Note that the program checks which values remained unchanged during the parametric study. For example, the engine inlet temperature will not change if the *Burner Exit Temperature* and the *HP Compressor Pressure Ratio* are the parameters. Since it does not make sense to plot constant values, the program will not show them in the plot parameter tree view on the left.

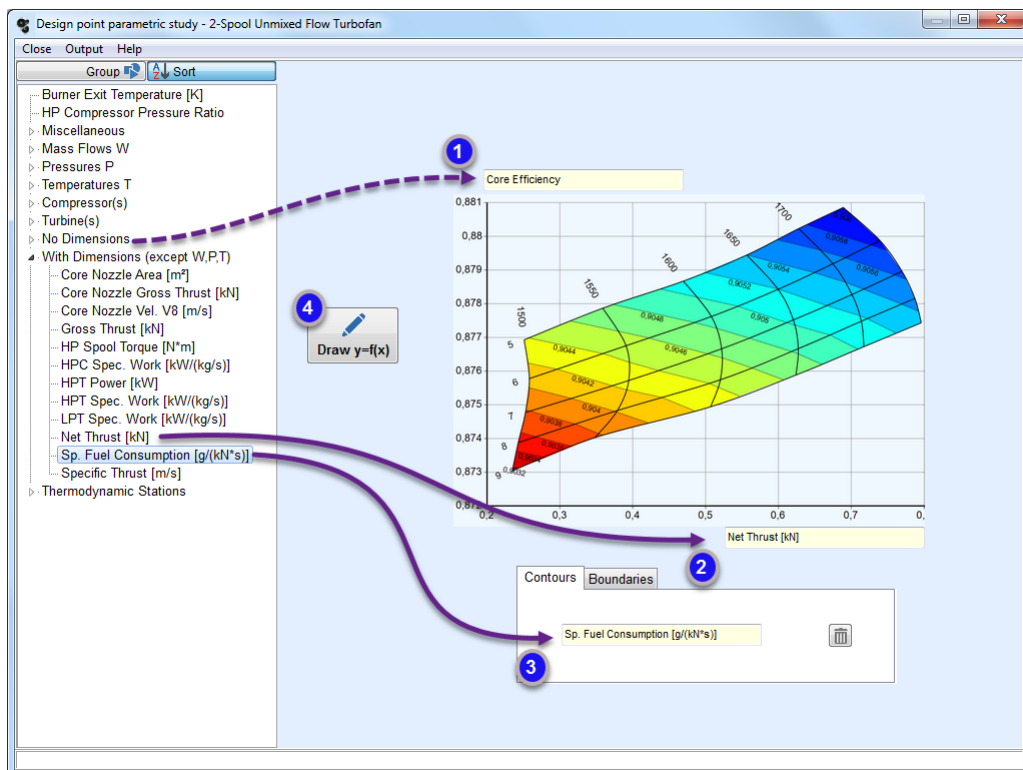

Picture definition with contour lines

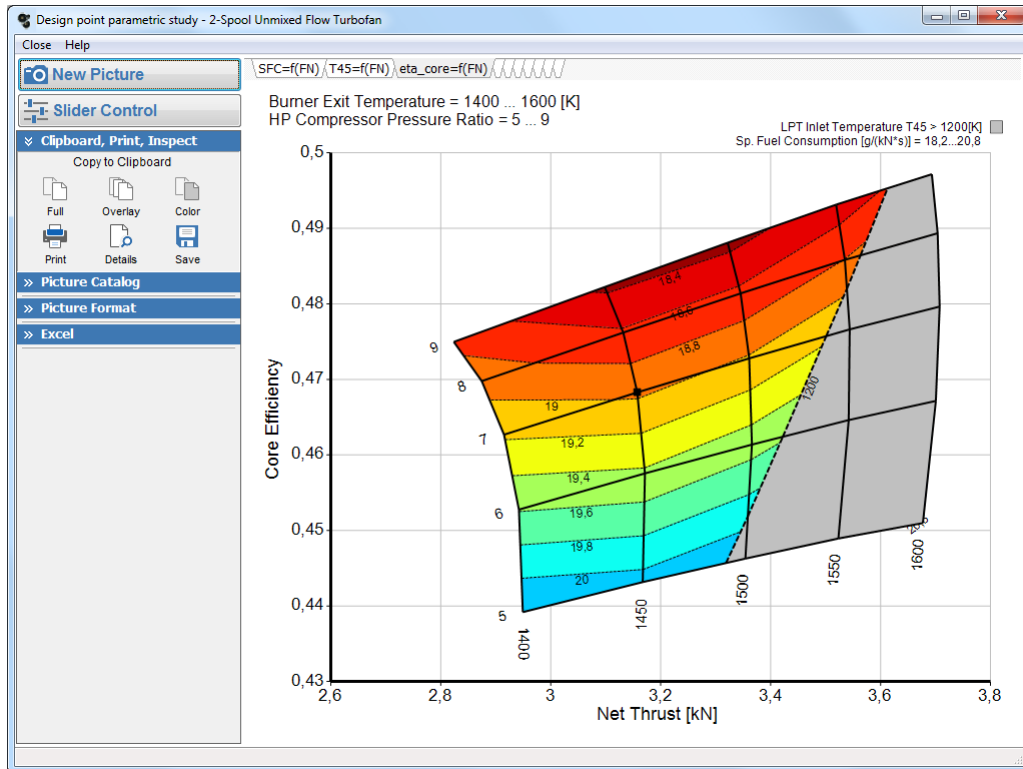

Example with contour lines and a boundary

For an alternate view on the same data set click the *New Picture* button; this will bring you back to the picture definition window. Play around with the options you have with the graphical output, test different plot parameter selections with or without contour lines and test also the boundaries.

When you are done with your plotting experiments select *Close* from the menu.

Repeat the parametric study with only one parameter. In such a case you can view the results in a graphic with up to *four y-axes* plotted over a common x-axis parameter.

1.3.2 Optimization

Instead of doing parametric studies for finding the best cycle you can employ numerical optimization. For the next example stay with the 2 SPOOL TURBOFAN configuration, re-load the file **Demo_tf.CYF** and run the design point calculation. Note the number for the thrust specific fuel consumption which is 18.984 in SI units.

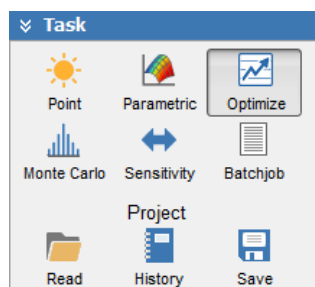

Close the single point output window and click *Optimize* in the *Task* button group. The caption of the top button is now *Optimize*.

Clicking the top button opens the optimization input window:

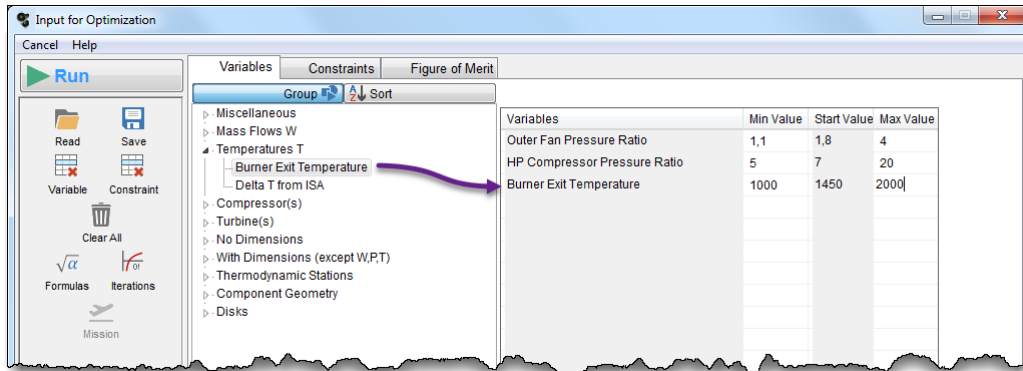

Here are the variables of the optimization selected: Take as the first variable the *Outer Fan Pressure Ratio*, enter for the minimum value 1.1 and for the maximum limit 4 in the first line of the table. Chose *HP Compressor Pressure Ratio* as the second variable with a lower limit of 5 and an upper limit of 20. As the third variable select *Burner Exit Temperature* and limit it to the range from 1000K to 2000K.

Finally the intent of the optimization has to be formulated. Click the tab *Figure of Merit* and pick *Sp. Fuel Consumption* from the list of output variables. Do not forget to choose *Minimize* - maximizing fuel consumption does not make sense.

The optimization window opens after clicking the *Run* button. There are three horizontal bars which represent the ranges of the three optimization variables. To begin with the optimization choose one of the four search strategies and click the *Run* button.

Not all optimization attempts yield a satisfying result. The Random strategies are very robust, however, they do not yield a very accurate result if the range of the optimization variables is wide. In this special example the *Systematic* strategy works very well. Play also with the other optimization strategies; finally you will find as the best cycle a parameter combination with a specific fuel consumption not higher than 17.0246 which is 10% less than the starting value of 18.984.

Click the (*Optimum*) button to get all the details of the optimized cycle. You will see, for example, that the ideal jet velocity ratio $V_{18}/V_{8,id}$ is around 0.745 which is near to the theoretically postulated optimum.

However, there might be a problem with the solution found: the *HP Compressor Pressure Ratio* is at its upper limit of 20. Possibly this is a true technical limit - or just an error in the specification of the range for this optimization variable. Further scrutinizing the optimum cycle output you will find that the *HPT Pressure Ratio* is 5.6. If you are looking for engines with single stage high pressure turbines then this value is much too high.

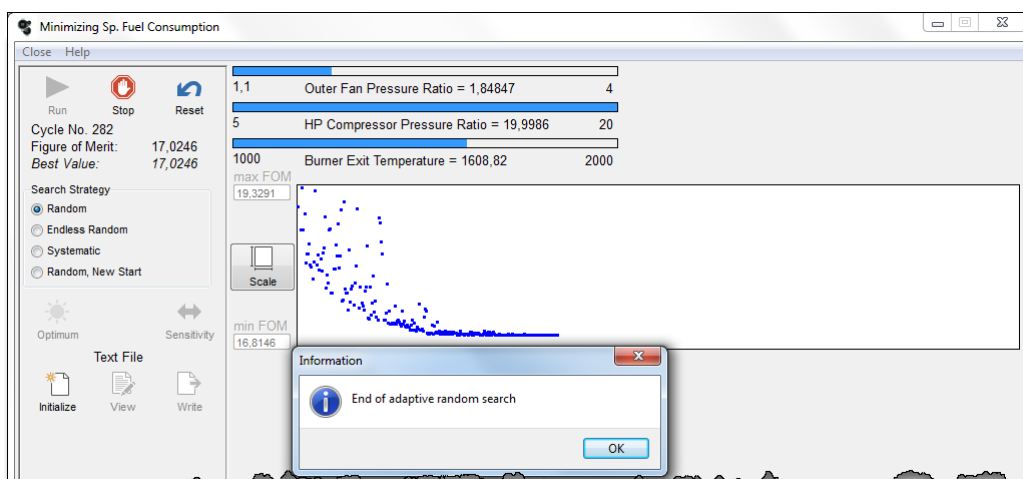

How can we find a more realistic optimal solution which takes into account that we are looking for engines with single stage HP turbines? Close the optimization window and answer the question *Restore old data?* with *yes*. Click the *Optimize* button again to reopen the optimization input window. Next click on the *Constraints* tab and select *HPT Pressure Ratio* as a constrained value for the optimization with the lower limit 0 and the upper limit of 4. Finally click the *Run* button again and you will get the figure below which includes now on the right side of the window a bar with the newly introduced design constraint.

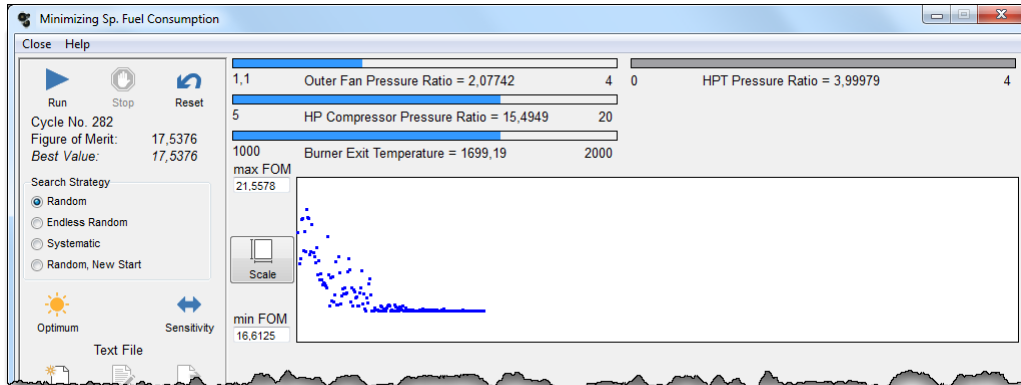

Running this optimization example yields a solution in which the *HP Compressor Pressure Ratio* is no longer at its limit. The *HPT Pressure Ratio* is exactly 4 and the specific fuel consumption is 17.6. This is higher than before, but still 7.3% better than the initial value.

1.3.3 Monte Carlo Study

In a Monte Carlo simulation many cycles with some randomly distributed cycle input parameters are calculated. Normal distributions with specified standard deviation will be created for the selected input parameters. The cycle output quantities will consequently also be randomly distributed. The results are presented graphically as bar charts together with a corresponding Gaussian distribution.

A typical application of the Monte Carlo method is the evaluation of the uncertainty of a quantity which is derived from the actual measurements. We use here as an example again the 2 SPOOL TURBOFAN configuration with the data from the file **Demo_tf.CYF**. Click in the tree view on *Test Analysis* and select test analysis mode *on*:

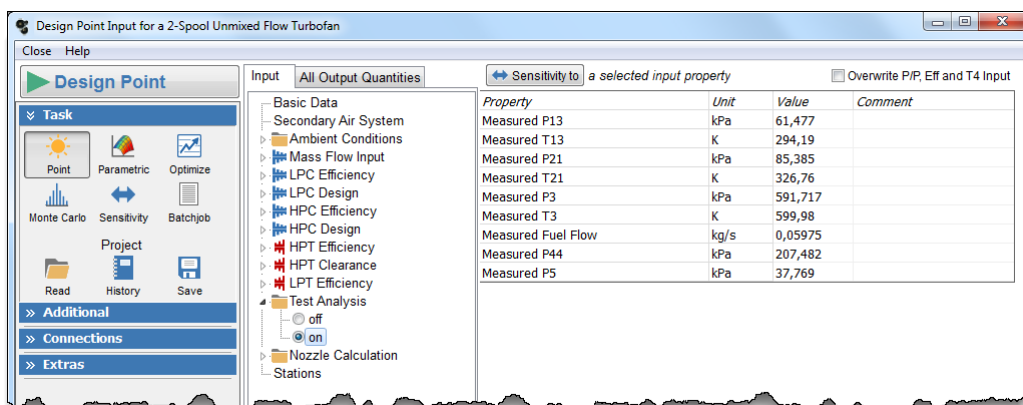

The measured values for the fuel flow, all the total pressures and temperatures in the compressor section, and the total pressures in the turbine section are input data for this special cycle calculation mode which yields the component efficiencies and other cycle parameters.

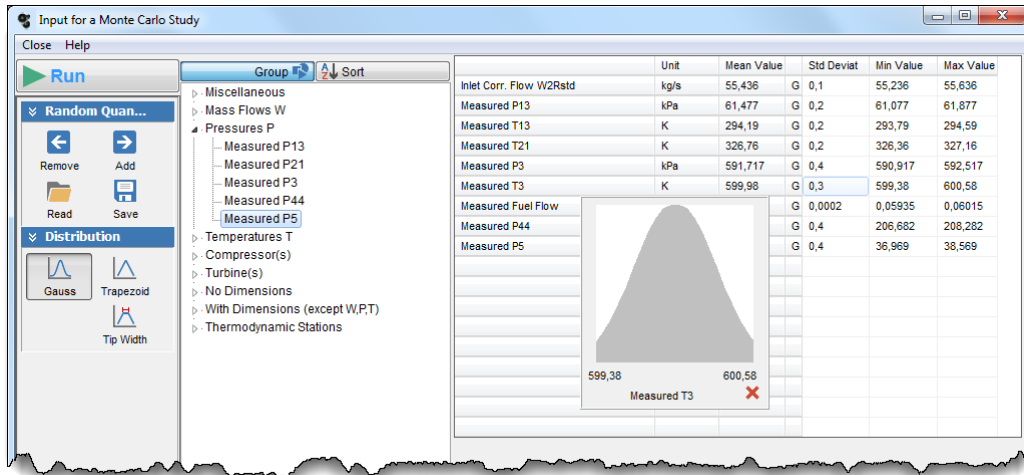

Each of the measured parameters has an uncertainty which is described with the standard deviation of the measured parameter. These standard deviations are input values for the Monte Carlo method. Before you actually start the Monte Carlo simulation you can select one of the randomly distributed parameters from a list. While the Monte Carlo simulation is running you can observe how the distribution of this parameter develops.

After starting the Monte Carlo simulation the program will run until you stop it. The first 2500 data sets are stored in memory; these data can be shown graphically in various formats. For a plotting the statistical distribution of any of the random parameters, select it from the tree view and then click the *New Picture* button.

The figure below shows that the statistical distribution of the *Isentropic LPT Efficiency* compared with that of a normal (Gauss) distribution. The latter is represented by the little yellow squares.

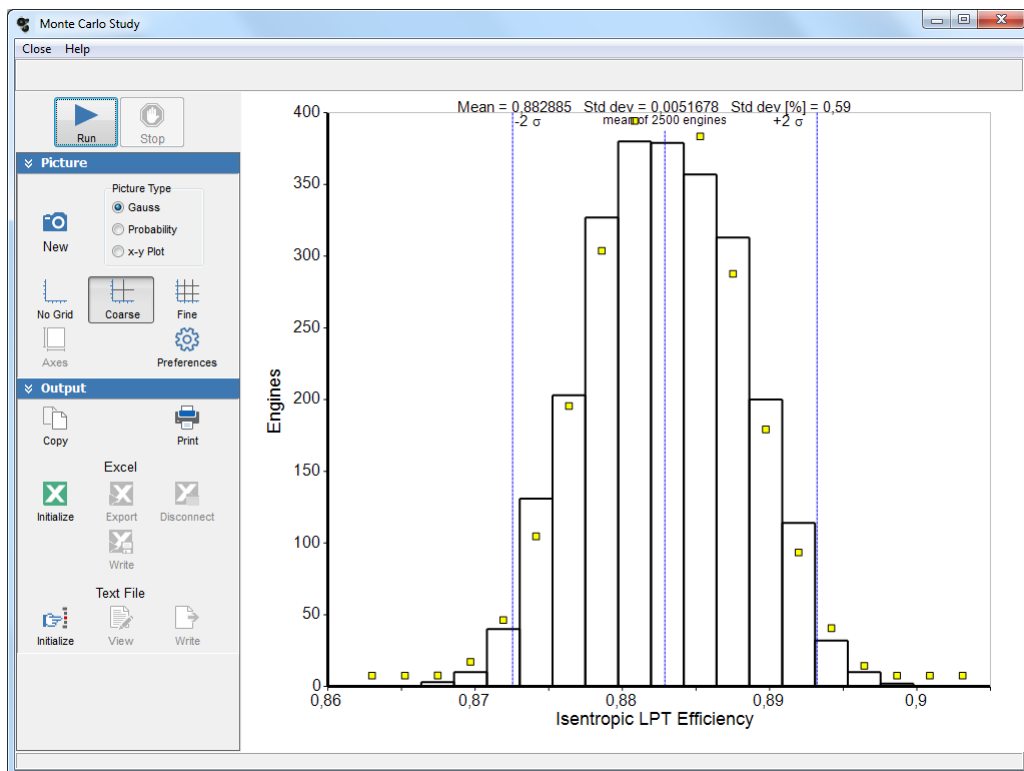

1.3.4 Effects of Small Changes

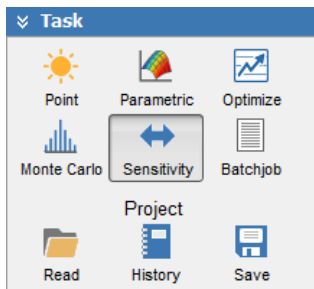

You may want to know how important one or the other input quantity is for a certain cycle; To learn this click the *Sensitivity* button. In the window that opens select the items you are interested in; you need not enter step sizes since they will be pre-selected automatically. If so you can adapt these step sizes to your needs.

Click on *Show the Effect of...* respectively on *the Result for...* to switch between input and output quantities. While the arrows in the middle of the window are pointing to the right, clicking them will transfer the selected item from the list on the left side to the appropriate selection list. Clicking on an item in the selection list activates arrows pointing to the left. Clicking a left pointing arrow removes the highlighted property from the selection list.

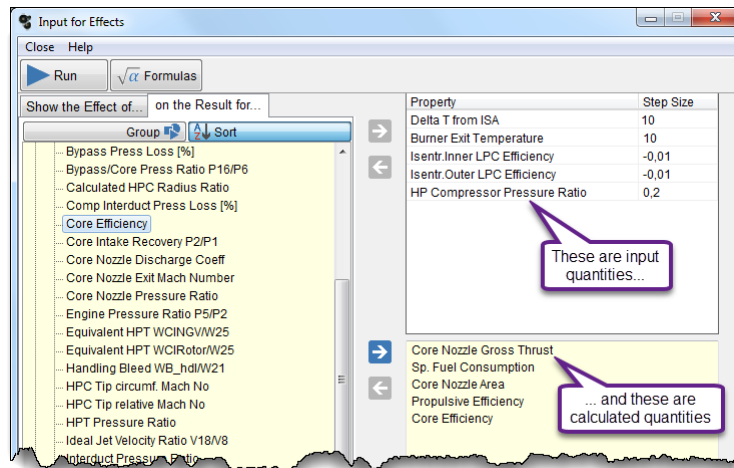

Click the *Run* button and you will get immediately a table with exchange rates:

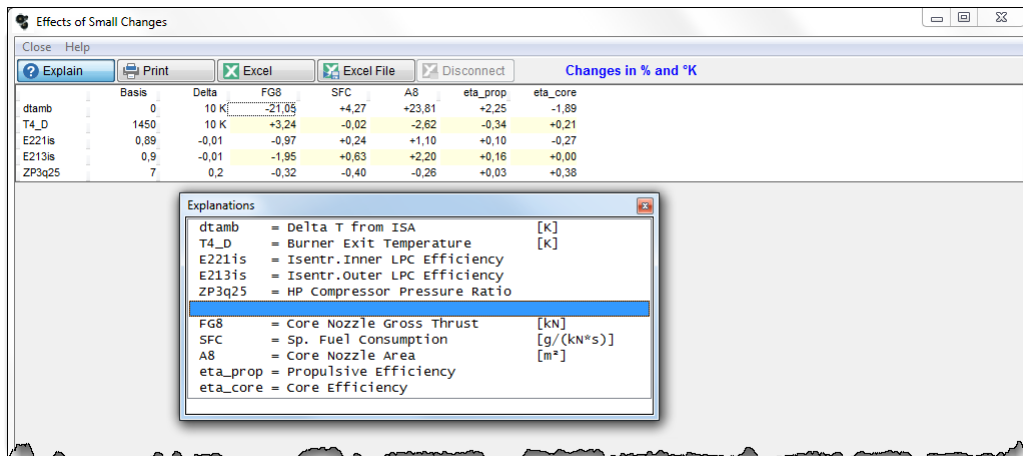

In the table the **short names** are used to save space. You will get explanations for these abbreviated names when you click the *Explain* button.

Be careful when interpreting the results of sensitivity studies. The changes are presented in terms of percentages and in degrees K (or R if you are using Imperial units). A 1% increase in efficiency with the basic efficiency equal to 0.8 means that the efficiency has changed from 0.8 to 0.808. You might have expected erroneously, that the efficiency increase would be from 0.8 to 0.81.



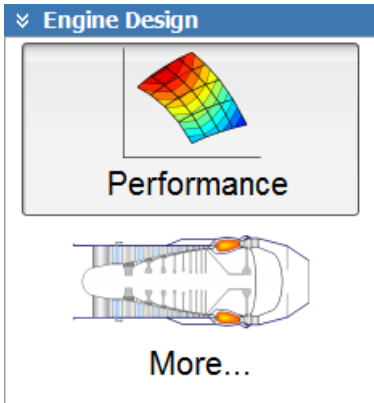

1.4 Off-Design Calculations

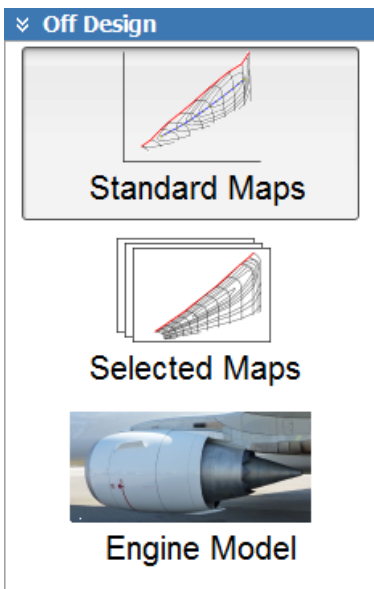

Use for this part of the tutorial the TURBOJET engine configuration. Do the cycle design calculation first: Click the *Performance* button in the *Engine Design* button group and load the file **Demo_jet.CYJ**. Calculate the cycle design point which yields the geometry of the engine. Then go back to the main window.



Click . This will show the *Standard Maps* and *Engine Model* buttons and change the heading of the *Engine Design* button group to . Click the *Standard Maps* button and that will in the background scale the standard component maps in such a way that they are consistent with the cycle design point and then the Off-Design Input window opens. Alternatively, click the *Selected Maps* button to choose from a pre selected catalog of standard maps for each component in a dialog that opens next. This allows for a more accurate calculation of component off-design performance. The selected maps will also be scaled to be consistent with the cycle design point. Afterwards, the Off-Design Input window opens

Note that you cannot change the scope while off-design is selected. Switching from *Performance* scope to the scope *More* (or the other way round) requires a new engine design calculation.

Only directly after starting the program you can go immediately to off-design simulations, without going first to engine design. Select the scope first and then click *Standard Maps*, *Selected Maps* or *Engine Model*. You will be prompted to read a data file. Before the off-design input window opens, the cycle design point is in the background calculated first.

1.4.1 Input Data For Off-Design Simulations

In the *Off-Design Input* window the contents of the table depends on your selection in the tree view, and - in case of the *Basic Data* - whether the *Inlet Flow Distortion* checkbox is checked.

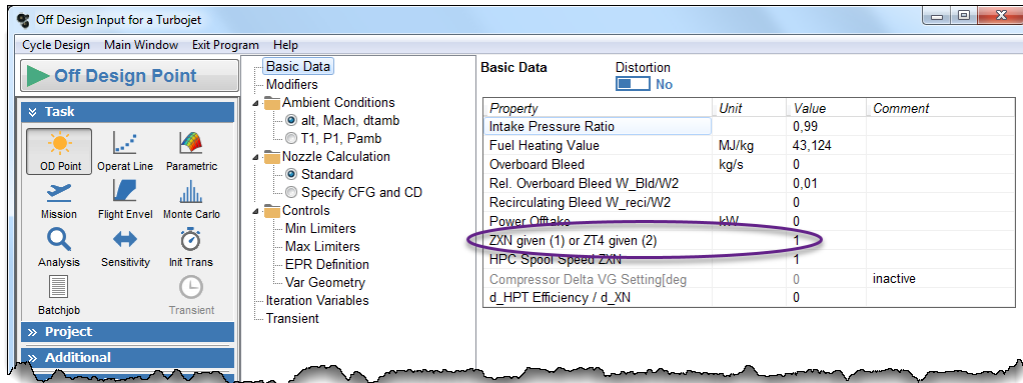

In the line *ZNX given (1) or ZT4 given (2)* there is a 1 which means that the engine operating condition is specified by the **relative high-pressure spool speed ZNX**. Do some experiments with various values of *HPC Spool Speed ZNX* in the range of 0.6...1.1 calculated as a single *Off-Design Point*.

Then switch to *ZNX given (1) or ZT4 given (2) = 2* which makes *Burner Temperature ZT4* an input quantity (instead of *HPC Spool Speed ZNX*) and do some more Off-Design simulations. If you specify very low values for Burner Temperatures *ZT4* below 800K then the iteration which is required for finding the solution may not converge. Click in the tree view on *Iteration Variables* and check if the values are suited as start value for a new calculation in such a case. If the values look suspicious, set them to the design point values, for example, and try again.

Alternatively you can load one of the backup files **Last_1_jet.CYJ**, **Last_2_jet.CYJ** or **Last_3_jet.CYJ** which contain the data of the last three converged calculations.

The group of data on the *Modifiers* page allows you to study changes of turbine flow capacity and nozzle area for the simulation of engines with variable geometry. If you want to study engine deterioration, apply Modifiers to the flow capacity and efficiency of the components and to duct and burner pressure ratios, for example.

During off-design calculations the number of input data is small because the basic behavior of the engine is fixed with the engine cycle design point. Duct pressure losses, for example, are specified for the cycle design point and will vary with corrected flow at part load. Therefore normally there is no need to enter any data for duct pressure losses during off-design calculations, and therefore you will not find the duct pressure losses among the off-design input data.

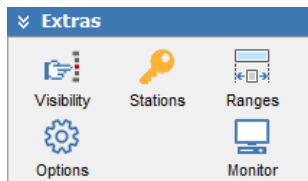

However, you might be interested in modifying cycle design input data not listed on the standard input page. You can make these data visible after clicking the *Input Visibility* button in the *Extras* button group.

1.4.2 Variable Compressor Geometry

On the *Var Geometry* page, which is a subsection of *Controls*, you can select one of the compressors having variable geometry. However, for most compressors having variable guide vanes in reality it is not necessary to choose the variable compressor geometry option in GasTurb for the simulation.

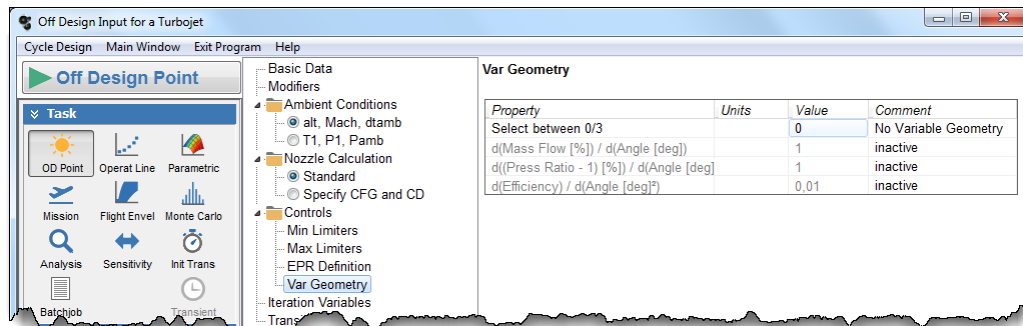

When to select Variable Geometry?

For a rigorous performance model of a compressor with variable geometry one needs many [maps](#). Each of these maps is valid for a given position of the variable guide vanes. While evaluating such a set of compressor maps within a simulation, the data must be interpolated between the appropriate maps as a function of the guide vane angle.

In nearly all real compressors that have several rows of variable guide vanes there is a mechanical link between the rows of guide vanes which enforces, that all vanes change their position simultaneously. A single actuator is sufficient to set all vanes accordingly to the demand of a controller. For fully describing the performance of a compressor with linked guide vanes one needs much less maps compared to the case in which the vane rows would be controlled independently from each other.

With most compressors the linked vane rows are controlled as a function of corrected compressor speed, the vane positions follow a simple schedule. This makes it possible to show the performance of the compressor in one one single map which is a combination of the speed lines from the various maps that are valid for the corresponding vane positions. Thus there is for the simulation no difference between compressors with fixed geometry and those which have their variable geometry position controlled as a function of corrected compressor speed because only one compressor map is needed.

In GasTurb you need to apply the variable compressor geometry option only if you want to study effects of deviations from the nominal geometry schedule of the map or in cases in which the vane position is deliberately not controlled as a function of corrected speed. The latter is the case with single spool gas turbines used for power generation, for example.

1.4.3 Maximum and Minimum Limiters

The maximum power available from a given engine depends on several limits such as the maximum spool speed, maximum temperature and maximum pressure. Which of the limiters is active depends, among other things, on the flight condition, the amount of power offtake and bleed air offtake. Besides the maximum limits for any gas turbine there are also minimum limits like gas generator spool speed at idle or minimum fuel flow, for example:



	Value	Maximum	On/Off
Spool Speed NH [%]	100,0	100	On <input checked="" type="checkbox"/>
Corr Spool Speed NHR [%]	100,0	105	On <input checked="" type="checkbox"/>
Comp Exit Temperature T3 [K]	630	690	Off <input type="checkbox"/>
Compr Exit Pressure P3 [kPa]	1204	1400	Off <input type="checkbox"/>
Turb Rotor Inl Temp T41 [K]	1411	0	Off <input type="checkbox"/>
Turb Exit Temperature T5 [K]	1091	1100	On <input checked="" type="checkbox"/>
Fuel Flow [kg/s]	0,6619	0	Off <input type="checkbox"/>
Net Thrust [kN]	26,3737	0	Off <input type="checkbox"/>
Engine Pressure Ratio EPR	3,6623	0	Off <input type="checkbox"/>

The program can observe several maximum and minimum limiters simultaneously. You can choose to run the engine at its maximum power (click the *Max Limits* button) or at its minimum power (*Min Limits*) or in between the defined limits (*Within Limits*).

Besides the pre-defined limiters you can employ up to three [composed values](#) as additional maximum and minimum limiters. Note that the drop-down lists with the composed values will appear only when composed values are defined.

The data in the table above have been created with the Turbojet example data file **Demo_Jet.CYJ**. One of the four activated limiters is T5 with a setting of 1100K. If you increase the T5 setting to 1150K then you will get an operating point with T5=1107K only. This is because the Spool Speed Limiter setting of 101 prevents achieving a higher temperature. The rules of the game are "Lowest Maximum Limiter Wins" and "Highest Minimum Limiter Wins".

If you switch on only *Max Limiters* then the program will run to one of the maximum limits and similarly if only *Min Limiters* are switched on then the solution will be at a minimum limit. If *Within Limits* is specified then the solution will be within the limits, but not necessarily at a *Min* or *Max* limiter. In special cases it can happen that the operation at the minimum limit violates a maximum limit. Then the minimum limit is ignored and the maximum limit dictates the operation of the engine.



1.4.4 Automatic Bleed

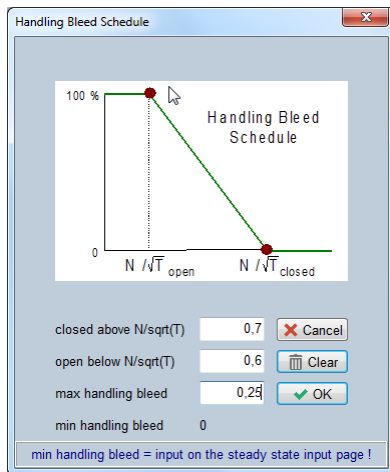

To control the compressor surge margin you can select an automatic handling bleed. This bleed discharges some of the compressed air into the bypass duct or overboard. You can thus lower the operating line of the compressor and avoid a surge. The automatic handling bleed will be modulated between the two switch-points that you specify.

The *Handling Bleed Schedule* input window is accessible from the *Controls* button group.

Test this feature by calculating two operating lines for the turbojet, one with and the other without

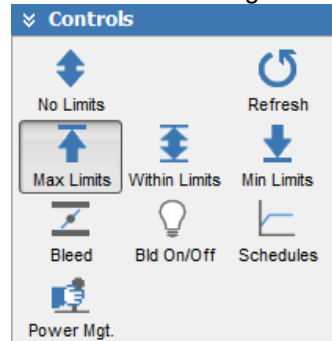

automatic handling bleed. Check the operating lines in the compressormap to see the gain in surge margin you are getting with the handling bleed.

1.4.5 Single Operating Line

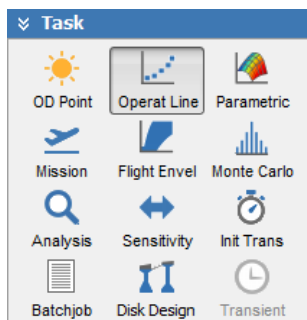

An operating line is a series of points which begins with the last calculated single off-design point. Choose in the *Task* button group the *Operating Line* button and then click **Operating Line** to open the Operating Line window.

Now you can specify the step size for the gas generator spool speed and the number of points to be calculated.

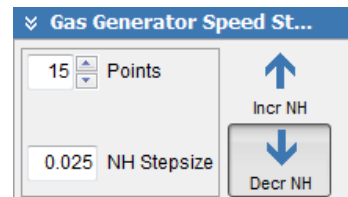

Furthermore you can decide to run the operating line as a series of points with **increasing** or **decreasing** spool speed. If the operating condition which you have calculated before switching to the operating line calculation mode is a low load case, then you should click the button with the arrow pointing upwards before commencing with the simulation.

Instead of specifying gas generator spool speed steps you can also run an operating line with equal thrust steps. Equal shaft power steps are an option with power generating engines. Not always will the specified number of points be achieved; if the operating line in one of the component maps is far outside of the valid region or when the iteration does not converge for other reasons then the calculation will stop prematurely.

As mentioned above, consecutive points are obtained by changing the relative high-pressure spool speed in steps of 0.025 (the default step size). An exception is the load variation with a [single spool turboshaft](#) as used for power generation which runs with constant spool speed.

A series of reheat part load points can also be an operating line in case of engines with an afterburner. If reheat is switched on, then the reheat exit temperature is decreased in steps of 100K. Note that the operating point in the turbomachinery component maps is the same for all points of a reheat operating line.

The operating line calculation ends with the question *More Operating Lines?* Answer *No* and examine the graphical output which includes the operating points in the component maps. On the page $Y=f(x)$ - after having clicked (*Details*) - you can select any of the calculated points by double-clicking and then check the cycle details.

1.4.6 Multiple Operating Lines

If you answer to the question More Operating Lines? with Yes then a window similar to the Mission Input window will open:

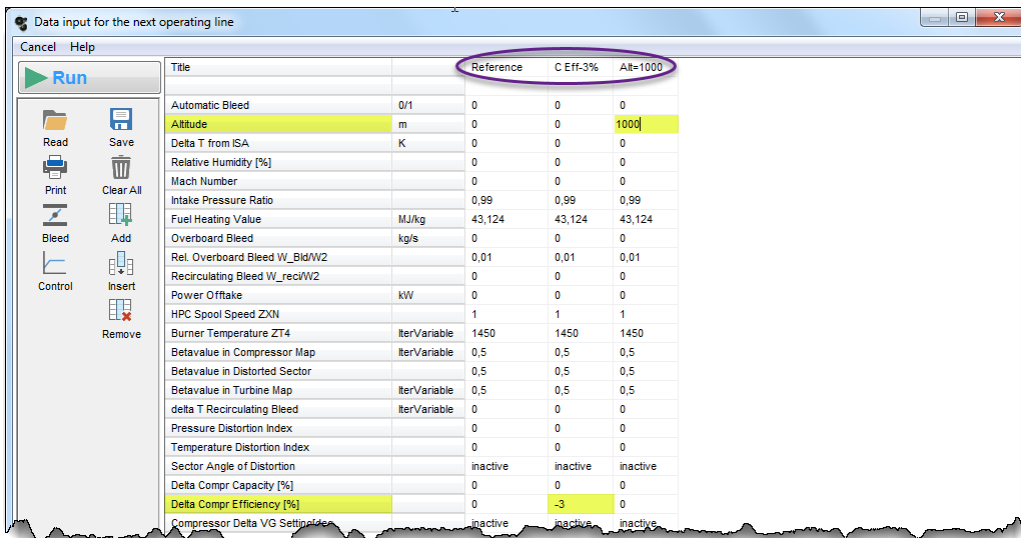

Title		Reference	C Eff-3%	Alt=1000
Automatic Bleed	0/1	0	0	0
Altitude	m	0	0	1000
Delta T from ISA	K	0	0	0
Relative Humidity [%]		0	0	0
Mach Number		0	0	0
Intake Pressure Ratio		0.99	0.99	0.99
Fuel Heating Value	MJ/kg	43,124	43,124	43,124
Overboard Bleed	kg/s	0	0	0
Rel. Overboard Bleed W_Bld/W2		0.01	0.01	0.01
Recirculating Bleed W_recir/W2		0	0	0
Power Offtake	kW	0	0	0
HPC Spool Speed ZXN		1	1	1
Burner Temperature ZT4	Iter/Variable	1450	1450	1450
Betavalue in Compressor Map	Iter/Variable	0.5	0.5	0.5
Betavalue in Distorted Sector		0.5	0.5	0.5
Betavalue in Turbine Map	Iter/Variable	0.5	0.5	0.5
delta T Recirculating Bleed	Iter/Variable	0	0	0
Pressure Distortion Index		0	0	0
Temperature Distortion Index		0	0	0
Sector Angle of Distortion		inactive	inactive	inactive
Delta Compr Capacity [%]		0	0	0
Delta Compr Efficiency [%]		0	-3	0
Compressor Delta VG Settings		inactive	inactive	inactive

After the reference column you can add as many operating conditions as you like. In the example above the second column applies Delta Compr Efficiency = -3% and the third column is for Altitude = 1000m. The text in the first row of the table can be edited, it is used for the symbol explanations in the pictures.

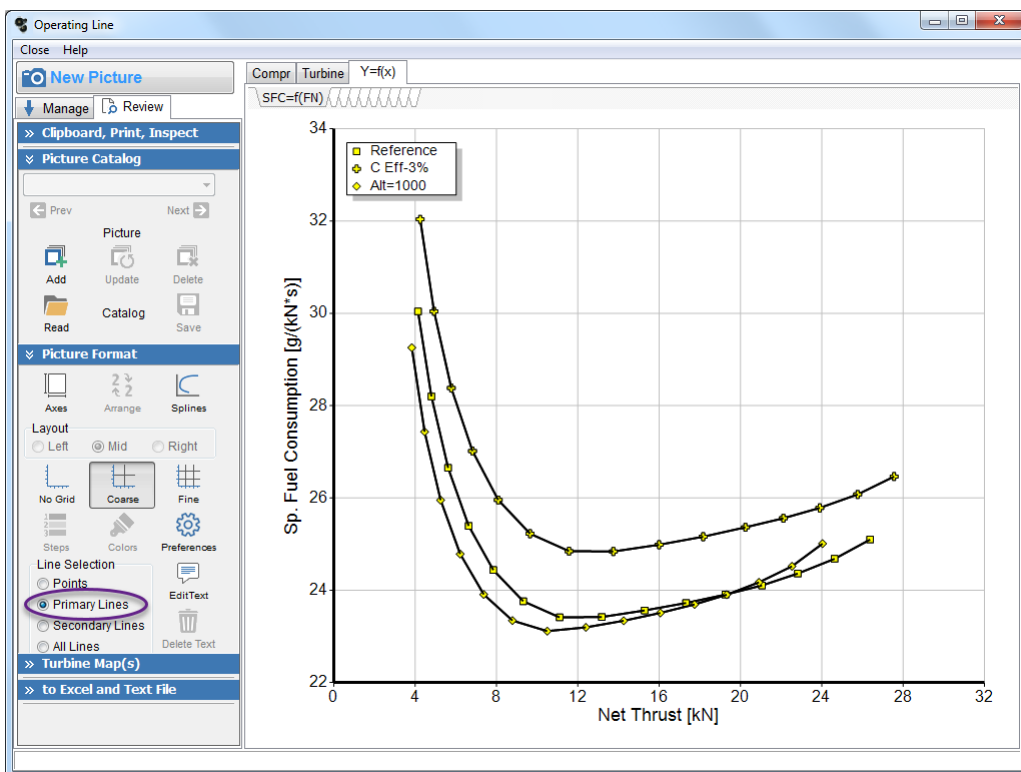

After clicking the Run button the program calculates for each column a full operating line. When done, the Operating Line Output window opens. Select in the Picture Format button group Primary Lines and you get this figure above.



1.4.7 Off-Design Parametric Study

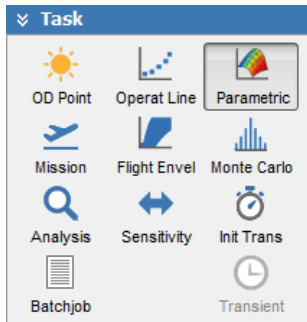

Instead of creating an operating line with several values for the high-pressure spool speed you can also produce a series of points with different amounts of power offtake and customer bleed air extraction, for example, by running an off-design parametric study. Click  to open the same input window as for design point parametric studies.

The operating points from a parametric study are shown in the component maps. The efficiencies calculated in the cycle may be not consistent with the graphical representation of the map because of Reynolds number corrections. So do not be surprised if you fail to find the same efficiency along the operating line in the HPC map and in a picture in which HPC Efficiency is plotted over HPC Mass Flow.

1.4.8 Mission Calculations

Often one has to look in detail at many different off-design conditions of a gas turbine. To do this easily, you may define a mission. You can combine up to 49 different operating conditions in a list of mission points. Such a list of points is also called a *Design Table*.



	Point 1	Point 2	Point 3	Point 4	Point 5	Point 6	Point 7	Point 8	Point 9
Show Result	yes	yes	yes	yes	yes	yes	yes	yes	yes
Description	Case 1	Case 2	Case 3	Case 4	Case 5	Case 6	Case 7	Case 8	Case 9
Altitude	m	0	0	0	0	0	2000	2000	2000
Delta T from ISA	K	0	0	0	0	0	0	0	0
Relative Humidity [%]		0	0	0	0	0	0	0	0
Mach Number		0	0,244	0,479	0,715	0,953	1,2	0,25	0,486
Intake Pressure Ratio		-1	-1	-1	-1	-1	-1	-1	-1
No (0) or Average (1) Core dP/P		1	1	1	1	1	1	1	1
Fuel Heating Value	MJ/kg	43,124	43,124	43,124	43,124	43,124	43,124	43,124	43,124
Overboard Bleed	kg/s	0	0	0	0	0	0	0	0
Rel. Overboard Bleed W_bld/W25		0,005	0,005	0,005	0,005	0,005	0,005	0,005	0,005
Recirculating Bleed W_rec/W25		0	0	0	0	0	0	0	0
Power Offtake	kW	0	0	0	0	0	0	0	0
Input Parameter 1		56,06	59,46	62,85	65,66	68,24	70,33	56,65	59,82
Input Parameter 2		117,8	113,2	115,3	122,5	135,6	153,5	94,3	101,7
ZXN given (1) or ZT4 given (2)		1	1	1	1	1	1	1	1

At the end of the mission input table there are the limiters listed. Here you can switch on several limiters for a mission point simultaneously. You can edit the limiter settings directly in the mission table or you employ the Limiter Input panel. Write the limiter settings for the selected point by clicking the *Write* button.

Note that you can not modify or switch on/off scheduled limiters in a mission input file. However, you can use as limiter a composed value which during the calculation reads data from a table.

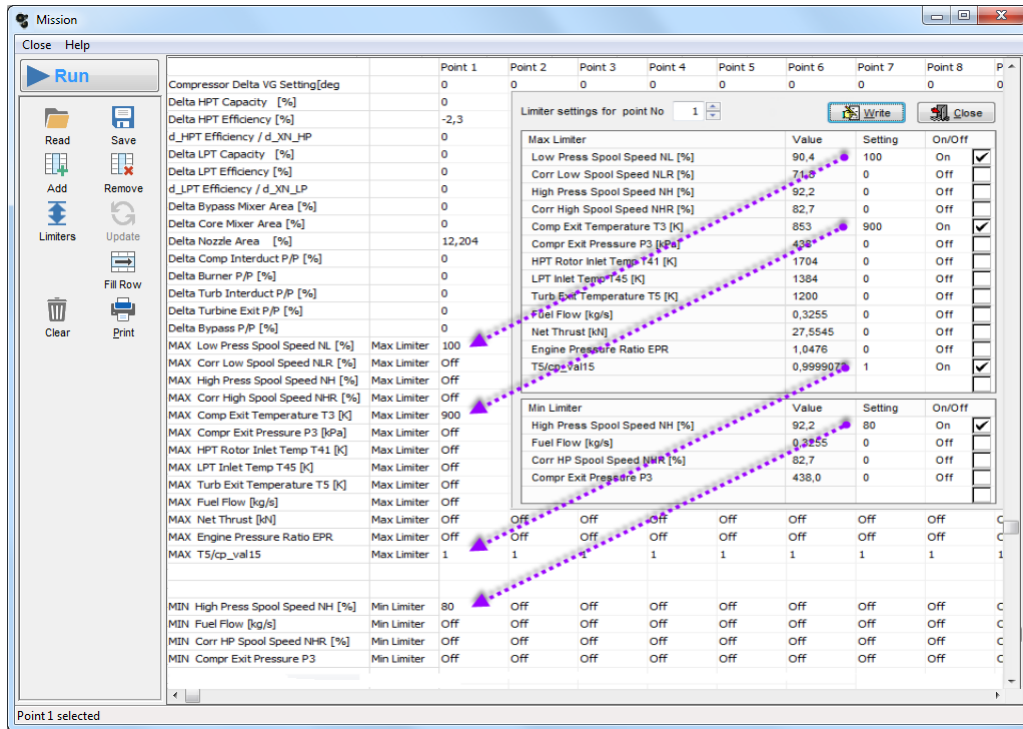
If in a mission both *Min and Max Limiters* are specified then the solution will be checked whether it is within the specified limits.



After starting the calculation all points in the list will be calculated in one run. As output you can get besides a summary table also detailed information for every single point. Click in the column of interest to select it and then click the  (*Details*) button. Furthermore, all points of a mission may be looked at in the component maps and other graphics, try the  (*Graphics*) button for that. Finally the table can also be [exported to Excel](#) or to an ASCII file with the extension OUM by selecting *File* *Export*.

1.4.9 Effect of Small Changes in Off-Design

Before you begin off-design sensitivity studies you must decide about the operating condition. Do you look for effects at constant thrust or at constant turbine inlet temperature? Set a single maximum limit first and choose from the *Task* button group the *Sensitivity* button. The further input for your off-design sensitivity study is formally similar to that already shown for cycle design.

There can be a big difference in the results found for small changes in compressor efficiency between [cycle design point](#) calculations and those for off-design. In the latter case all the operating points are moving around in their component maps and it even might happen that decreasing the quality of a component improves performance!



1.4.10 Flight Envelope

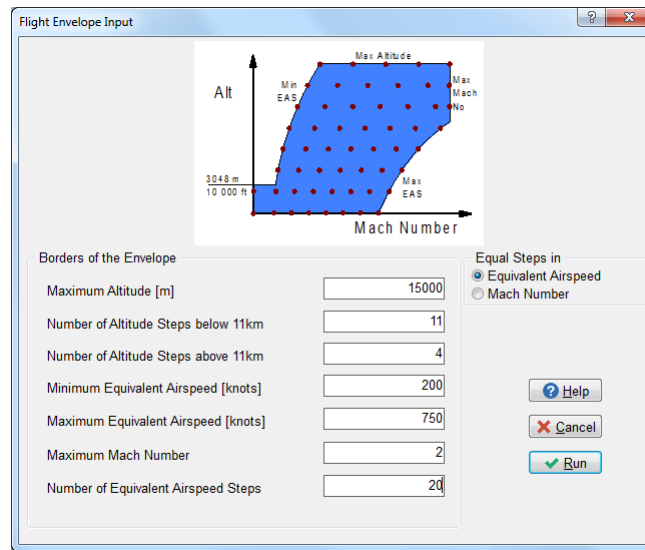

After activating one or several maximum limiters or control schedules you can calculate a series of points with different altitudes and Mach numbers throughout a flight envelope. A flight envelope always starts at sea level and extends to the specified altitude. Two limiting speed values are entered as equivalent air speed EAS. This is the speed at which the airplane must fly at some altitude other than sea level to produce the same dynamic pressure as at sea level. EAS is traditionally measured in knots and differs from the true airspeed by the square root of the density ratio ρ/ρ_0 .

There are four speed limits that define the flight envelope. For altitudes lower than 3048 m (10000 ft) the flight envelope extends to zero speed. Above this altitude the limit of the flight envelope is the minimum Equivalent Air Speed. The maximum speed is described by both a maximum EAS and by a maximum Mach number (lowest is used). A simplified definition of the flight envelope yields the engine performance for equal steps in altitude and Mach number.

The first point calculated is always sea level static. This point must converge; otherwise, the calculation will stop with a corresponding message. As the first graph you are offered a plot of the flight envelope in which you can see which limiter is active at any altitude and Mach number combination.

1.4.11 Off-Design Monte Carlo Study

With the Monte Carlo method - which was already introduced for cycle design - you can simulate the off-design performance variations that result from random changes of the component behaviour due to manufacturing and assembly tolerances in a series production of engines. See which component production and control system tolerances you can afford without getting an excessive scatter in pass-off thrust or specific fuel consumption.

The random distributions for all input data are all independent of each other. There is one exception to this rule: you can choose that flow and efficiency scatter of compressors are correlated. This is because a compressor with an efficiency level lower than the mean value will most probably also have a corrected flow at a given speed, which is lower than average.

1.4.12 Transient

If the Scope is Performance, then only a few input data for transient simulations are needed. The simulation considers the polar moment of inertia as the only difference to steady state operation.

More detailed simulations require many additional geometry and material data which are only available to the program if the scope *More..* has been selected for the engine design calculations.

Most of the additional data on the transient input page describe a simple proportional-integral-differential control system. In GasTurb 13 the Power Lever Angle PLA is directly proportional to the mechanical spool speed for thrust producing engine types. In the case of a turbojet, there is a **linear relationship** between PLA and the compressor spool speed. This relationship is defined by the input for *rel N for PLA=0%* and *rel N for PLA=100%*.

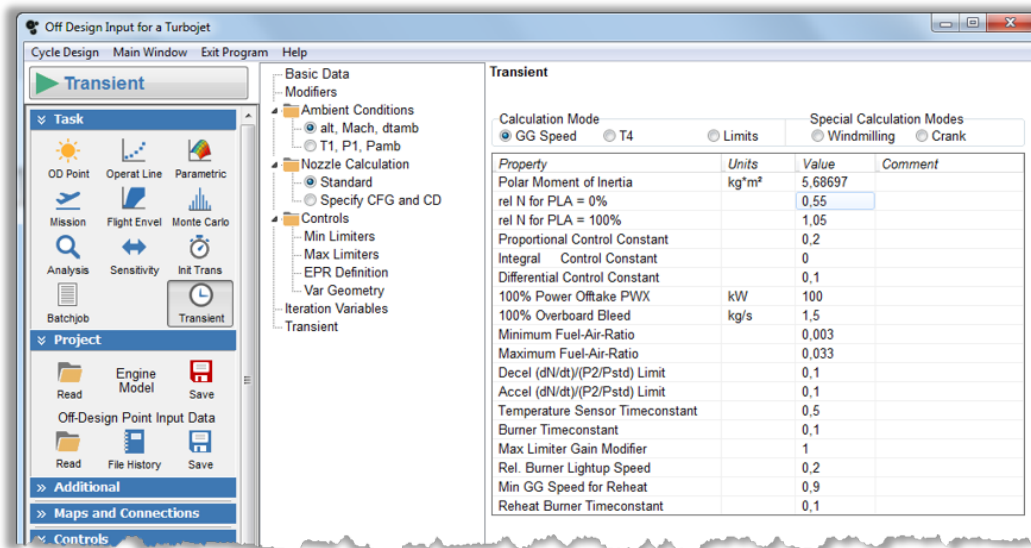
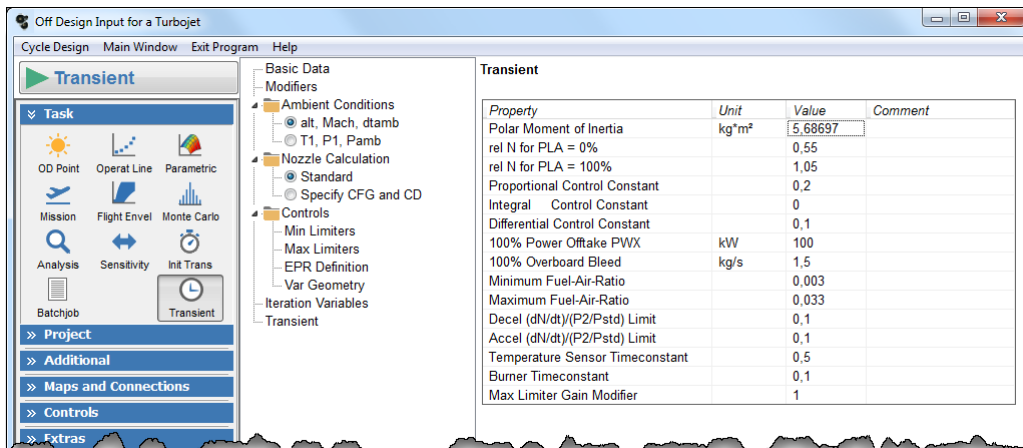

Before actually starting transient simulations you need to initialize this calculation mode by calculating a reference operating line. The actual transient simulation begins with steady state operation at the operating point which has been calculated as a single cycle before selecting  (*Initialize Transsient*). Therefore, if you want to study the acceleration of an engine, you need to calculate the steady state idle operating condition before initializing the transient mode.

The results of the initialization are used for setting the scales in the overview plot of the transient simulation. The reference operating line points (which are all steady state operating points) are shown for comparison together with the transient data in the graphic output.

For your first experiments with transient simulations use the turbojet with the data from the file **Demo_jet.CYC** again. Run a single cycle with Z_{XN}=1 as steady state operating point before



initializing transient. After having closed the window with the reference operating line click  (*Transient*) and then the top left button to open the transient simulation window.

You can select between several alternatives for the time dependent input. When *Pilots Lever = f(Time)* is selected, then the transient maneuver is defined by the schedule in the top part of the Overview. Add, move and delete breakpoints of the schedule with a few mouse clicks. Start the simulation by clicking the to left button.

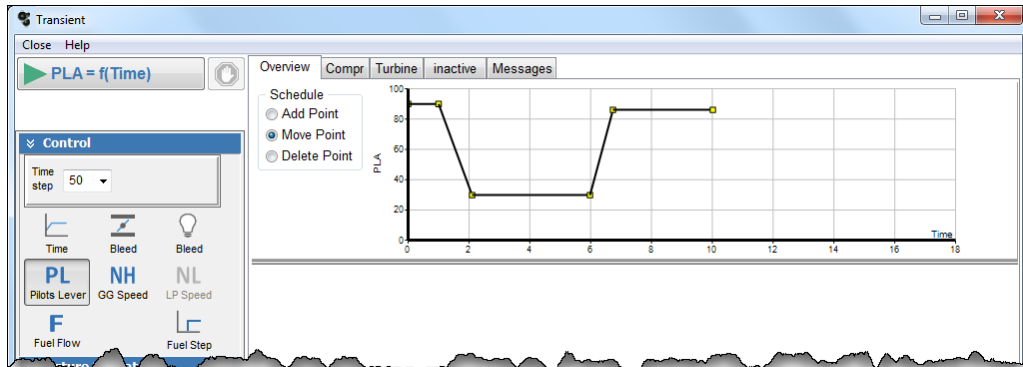

It depends on the complexity of the engine model and on the performance of the computer whether the simulation will run in real time. The program makes sure that the simulation is not faster than real time.

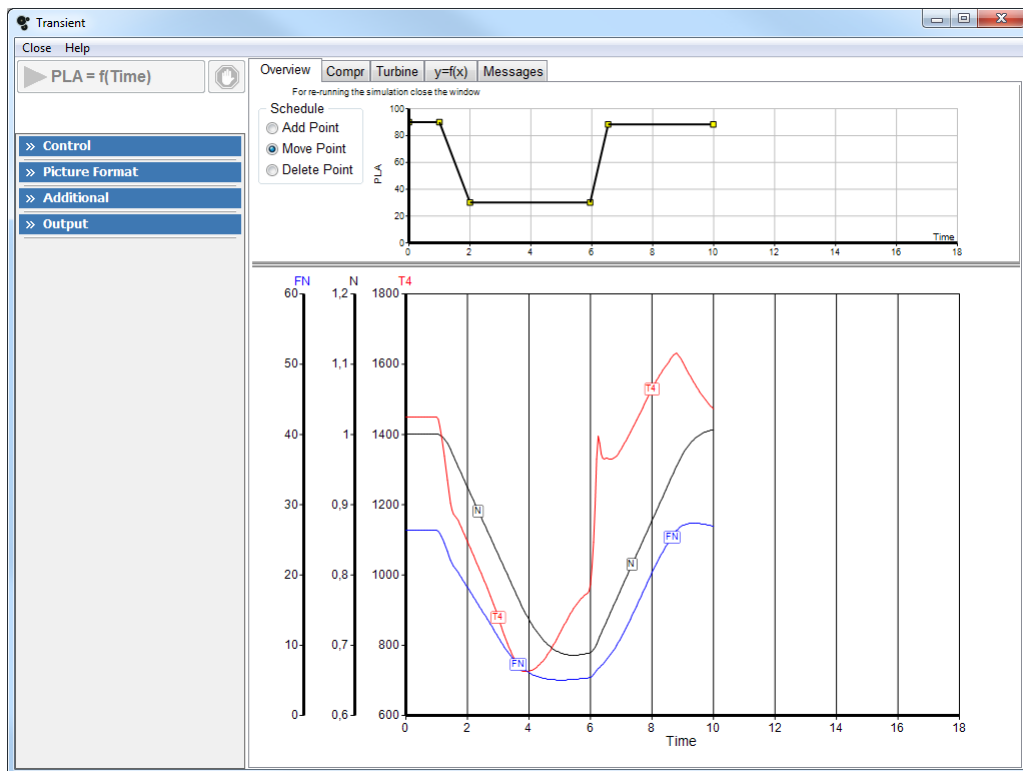

After the transient maneuver is completed, you can look at the operating points in the component maps and also at any other graphical output. On the Messages page there is information about convergence of the transient calculations, the reaction of the control system and other details.

1.4.13 Test Analysis by Synthesis

The **conventional test analysis** makes no use of information that is available from component rig tests, for example. It will give no information about the reason why a component behaves badly. A low efficiency for the fan may be either the result of operating the fan at aerodynamic over-speed or a poor blade design. To improve the analysis quality in this respect is the aim of the *Analysis by Synthesis (AnSyn)*. This method is also used for model based engine performance monitoring.

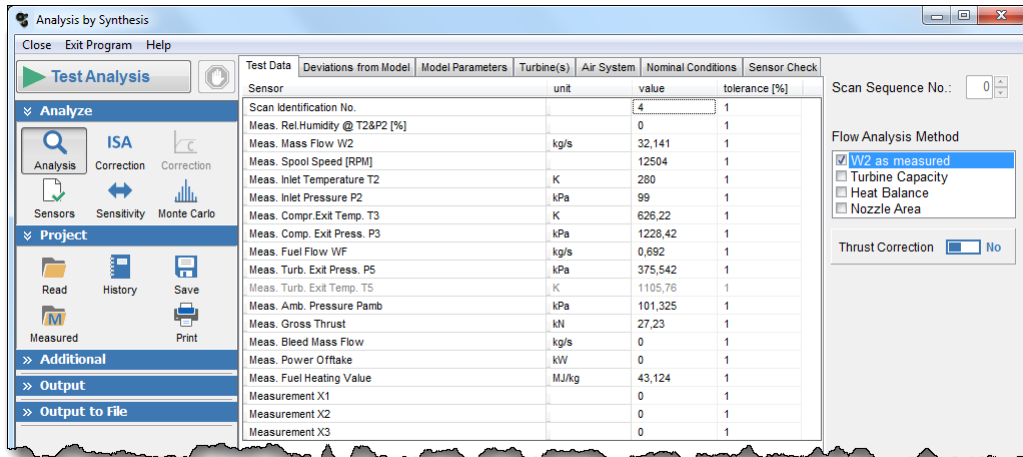

From the screen shot of the AnSyn main window above you see that there are many options available. Most of them need detailed explanations and are therefore not suited for newcomers to the program. If you are interested in this topic please search for the topic **Model Based Test Analysis** in the section dealing with the details of off-design simulations.

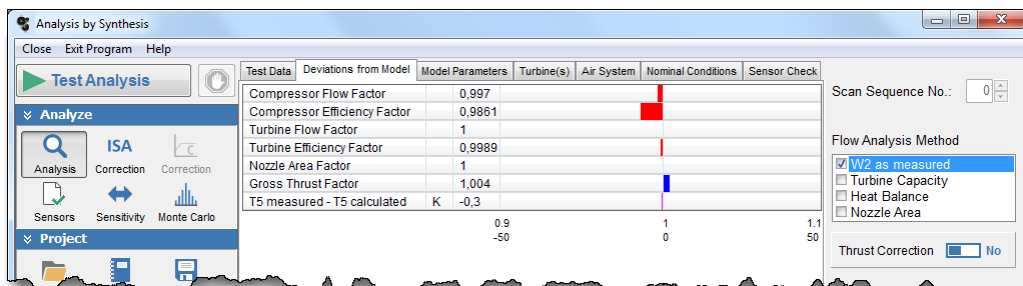

When doing analysis by synthesis a model of the engine is automatically matched to the test data. This is achieved by applying scaling factors to the component models in such a way that the measured values and the model values come into agreement. An efficiency scaling factor greater than one indicates, that the component performs better than predicted, for example. In case of the example above a compressor efficiency factor of 0.986 is found which means, that compressor efficiency is 1.4% lower than postulated by the model.



1.5 More than Performance

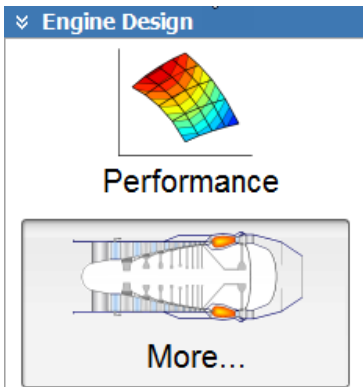

Gas turbine performance simulations can be done without knowing the detailed geometry of the components. No static pressures, temperatures or flow velocities inside the compressors, burners, ducts or turbines need to be considered, only the total pressures and the total temperatures are necessary for the calculation of the thermodynamic cycle.

However, if you want to know more about the internals of your engine, then you have to consider local Mach numbers, flow areas, densities, velocities etc. Select in the program main window *More* as scope of the simulation and you can study these details. Choose the **TURBOJET** configuration and use the data from the **Demo_jet.CYJ** for the following example.

While the program scope is *More*, the geometry of the engine can be calculated from the cycle results employing the flow areas at the thermodynamic stations. These calculations can require considerable computer power and therefore they are disabled at program start. Activate them by clicking (*Enable Geometry*) and then click (*Edit Geometry*) to open the engine geometry editor. You will immediately see the turbojet cross section which is consistent with the cycle data.

The input and output data for the geometry and the disks are grouped for each component. Have a quick look at them to get a first impression about the detail which GasTurb 13 can consider for preliminary engine design tasks. For a more detailed view about the program capabilities and limitations read the section about Engine Dimensions.

To end the Getting Started tour through the program let's have a little fun: Click and assign the *HPC Annulus Shape Descriptor* to a slider. You find this parameter in the subsection *Compressor* of the *Component Geometry* section. See how the shape of the compressor annulus affects all the rest of the engine; try also other input data with the slider, for example the cycle input data.

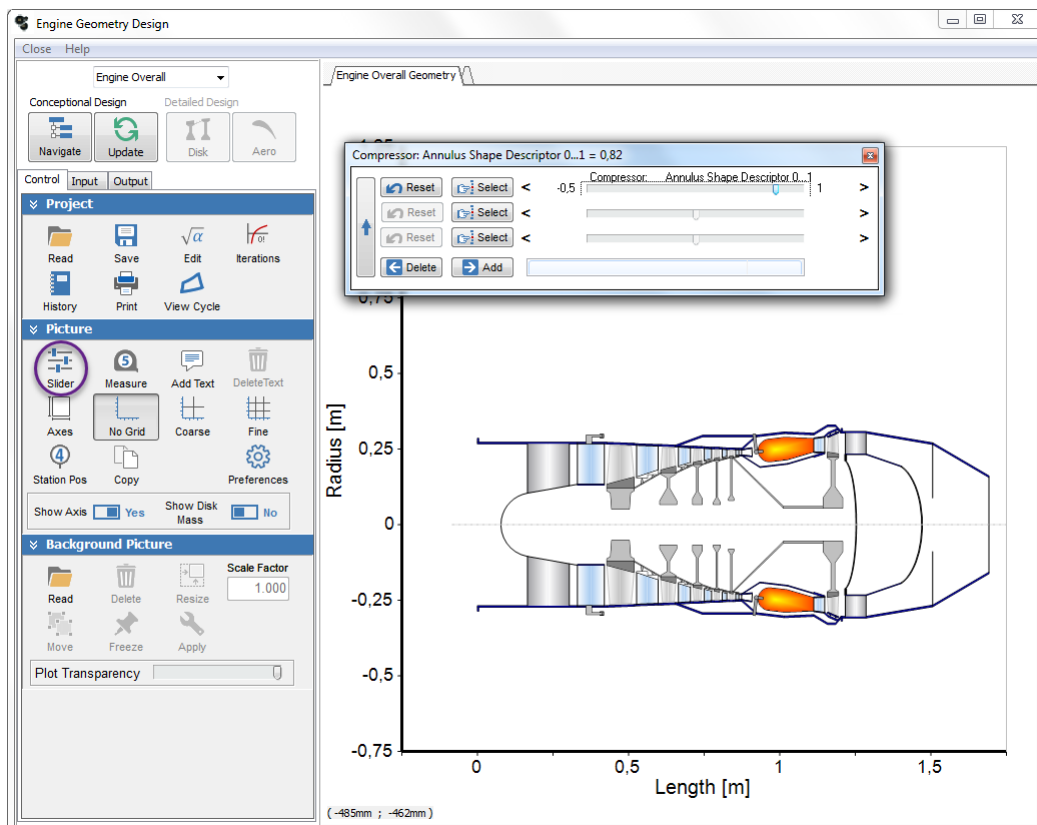

This ends the *Getting Started* section, for more information about the capabilities of GasTurb 13 go through the rest of the help system section by section or use the index for searching a specific topic. If you have difficulties understanding one or the other explanation - or if you find a bug in the manual or in the program - feel free to send a message about the problem to the author.

The Cycle Design Point

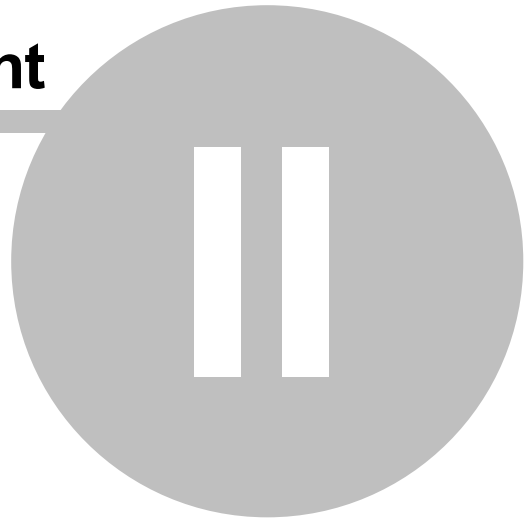



2 The Cycle Design Point

Many possible thermodynamic cycles are evaluated before a new gas turbine can be designed. In the end, a cycle is selected which constitutes the *cycle design point (cycle reference point)* of the gas turbine. For this design point all the mass flows, the total pressures and total temperatures at the inlet and exit of all components of the engine are given. Moreover, the flow area at the exhaust is already determined.

Selecting appropriate Mach numbers at the component boundaries freeze all aero-thermodynamic important dimensions of the gas turbine. Thus selecting a cycle design point defines the geometry of the gas turbine. Always keep in mind:

Cycle design point studies compare gas turbines of different geometry.

Off-design studies deal with the behavior of a gas turbine with known geometry.

Prior to off-design simulations you must run a single cycle design point. This calculation will be done automatically if you select  in the program main window immediately after starting the program and then go on with a click on *Standard Maps* or *Engine Model*.

2.1 Input Data

2.1.1 Basic Data

You create a new input data set by modifying an existing data set; there is no option available to create it from scratch. The following sections describe the data input for cycle design calculations for the example of the *Geared Unmixed Flow Turbofan (Geared Turbofan A)* configuration if not otherwise stated. You can use any editor to look at the data, they are pure ASCII files. However, it is strongly recommended not to modify data sets in your editor if you are not absolutely sure about the meaning of the data groups and the terms employed in the data file.

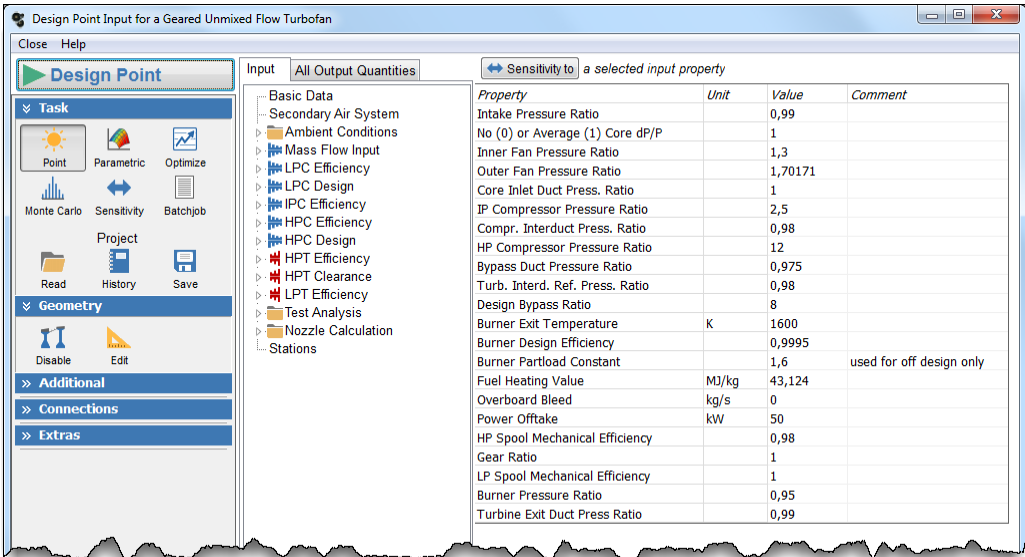

Property	Unit	Value	Comment
Intake Pressure Ratio		0,99	
No (0) or Average (1) Core dP/P		1	
Inner Fan Pressure Ratio		1,3	
Outer Fan Pressure Ratio		1,70171	
Core Inlet Duct Press. Ratio		1	
IP Compressor Pressure Ratio		2,5	
Compr. Interduct Press. Ratio		0,98	
HP Compressor Pressure Ratio		12	
Bypass Duct Pressure Ratio		0,975	
Turb. Interd. Ref. Press. Ratio		0,98	
Design Bypass Ratio		8	
Burner Exit Temperature	K	1600	
Burner Design Efficiency		0,9995	
Burner Partload Constant		1,6	used for off design only
Fuel Heating Value	MJ/kg	43,124	
Overboard Bleed	kg/s	0	
Power Offtake	kW	50	
HP Spool Mechanical Efficiency		0,98	
Gear Ratio		1	
LP Spool Mechanical Efficiency		1	
Burner Pressure Ratio		0,95	
Turbine Exit Duct Press Ratio		0,99	

There are several options for describing the **intake pressure loss**. The **burner part load constant** is relevant for off-design simulations only, ignore it if you do only cycle design studies. If you intend to do off-design simulations after having decided for a cycle design point and you have no idea about its magnitude then use the default value 1.6.

You can select between several different [fuel types](#) from in the *Connections* button group. Each fuel type has its nominal *Fuel Heating Value* (FHV). You can modify the default FHV which makes sense especially if you want to simulate the use of *Natural Gas* with a slightly different chemical composition compared to that assumed by GasTurb 13.

The engine configurations with several turbines have inter-ducts between these turbines that cause pressure losses. If you do not select the [Turbine Design](#) option for the turbine upstream of the inter-duct then the input value for *Turb. Interd. Ref. Press. Ratio* will be the actual turbine inter-duct pressure ratio.

With *Turbine Design* selected, the given *Turb. Interd. Ref. Press. Ratio* is valid for the *Interduct Reference Mach No.* which is an input on the *Turbine Design* page. If the exit Mach number of the upstream turbine deviates from the *Interduct Reference Mach No.*, then the calculated interduct pressure ratio will deviate correspondingly from the *Turb. Interd. Ref. Press. Ratio*.

2.1.2 Secondary Air System

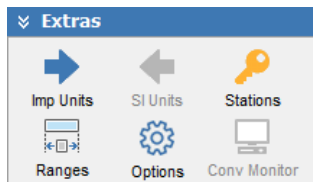

An enlarged version of the nomenclature figure opens after clicking the *Stations* button in the *Extras* button group. You can print the figure with the station nomenclature and the secondary air system paths from the cycle result sheet.

Bleed Air

A *handling bleed* is used for lowering the operating line in a compressor and thus protecting the engine from surge. The *handling bleed* may be downstream of the compressor or it can be an inter-stage bleed. When studying a mixed flow turbofan then you must specify the handling bleed location: For high bypass engines usually you need a handling bleed valve downstream of the booster and for low bypass engines you might need a handling bleed for the HP compressor.

The overboard bleed is for cabin air ventilation in an aircraft, for example. According to [Reference 1](#) around 0.01kg/s per passenger is required. In industrial engines the required amount of overboard bleed is usually less than 1% while with marine engines up to 10% of the engine mass flow is used.

The location of an inter-stage bleed within a compressor is specified by the [relative enthalpy rise](#).



Property	Unit	Value	Comment
Rel. Handling Bleed to Bypass		0	
Rel. HP Leakage to Bypass		0	
Rel. Overboard Bleed W_Bld/W25		0	
Rel. Enthalpy of Overb. Bleed		1	
Recirculating Bleed W_reci/W25		0	Off Design Input Only
Rel. Enthalpy of Recirc Bleed		1	
Number of HP Turbine Stages		2	
HPT NGV 1 Cooling Air / W25		0,05	
HPT Rotor 1 Cooling Air / W25		0,06	
HPT NGV 2 Cooling Air / W25		0,03	
HPT Rotor 2 Cooling Air / W25		0,01	
HPT Cooling Air Pumping Dia	m	0	
Number of LP Turbine Stages		4	
LPT NGV 1 Cooling Air / W25		0,02	
LPT Rotor 1 Cooling Air / W25		0,005	
LPT NGV 2 Cooling Air / W25		0	
LPT Rotor 2 Cooling Air / W25		0	
Rel. Enth. LPT NGV Cooling Air		0,6	
Rel. Enth. of LPT Cooling Air		0,7	
Rel. HP Leakage to LPT exit		0	
Rel. Fan Overb.Bleed W_Bld/W13		0	
Core-Byp Heat Transf Effectiven		0	
Coolg Air Cooling Effectiveness		0	
Bleed Air Cooling Effectiveness		0	

Turbine Cooling Air

For each multistage turbine there are four cooling air values, they differ in the amount of work they do in the turbine:

NGV 1 Cooling Air / W25	does work in all rotors
Rotor 1 Cooling Air / W25	does work in all rotors except rotor 1
NGV 2 Cooling Air / W25	does work in all rotors downstream of rotor 1
Rotor 2 Cooling Air / W25	does work in all rotors downstream of rotor 2

From these four values there are two substitutes created. These substitutes are the cooling air flows of an equivalent single stage turbine. For the HPT in the numerical example above, the equivalent single stage NGV Cooling Air is 0,095 and the equivalent Rotor Cooling Air 0,55. The equivalent LPT numbers are 0,02375 and 0,00125. The equivalent cooling air numbers are shown in the single point output both on the Summary and the Air System Pages.

Heat Transfer in Bypass Engines

In bypass engines there is some heat transferred from the core to the bypass. This phenomena can be simulated as a heat exchanger. The hot side inlet temperature to this heat exchanger is the compressor exit temperature T_3 , the cold side inlet temperature is T_{13} . The heat exchanger exit temperatures are T_{31} respectively T_{18} . The amount of heat transferred is a function of the Core-Bypass [Heat Transfer Effectiveness](#).

Overboard bleed air can be cooled in the bypass, the Bleed Air Cooling Effectiveness describes implicitly the size of the cooler. In off-design simulations the Bleed Air Cooling Effectiveness will be a function of the bleed mass flow. This is because for each cooler, when the bleed air mass flow is zero, the Bleed Air Cooling Effectiveness must be 1.0. For making the Bleed Air Cooling Effectiveness a function of bleed air mass flow use composed values and an additional iteration.

Cooling the HPT cooling air heats the bypass air and decreases the temperature of the cooling air. The magnitude of the effect is described with the Cooling Air Cooling Effectiveness. The picture, taken from Ref. 29, shows how such a device could look like:

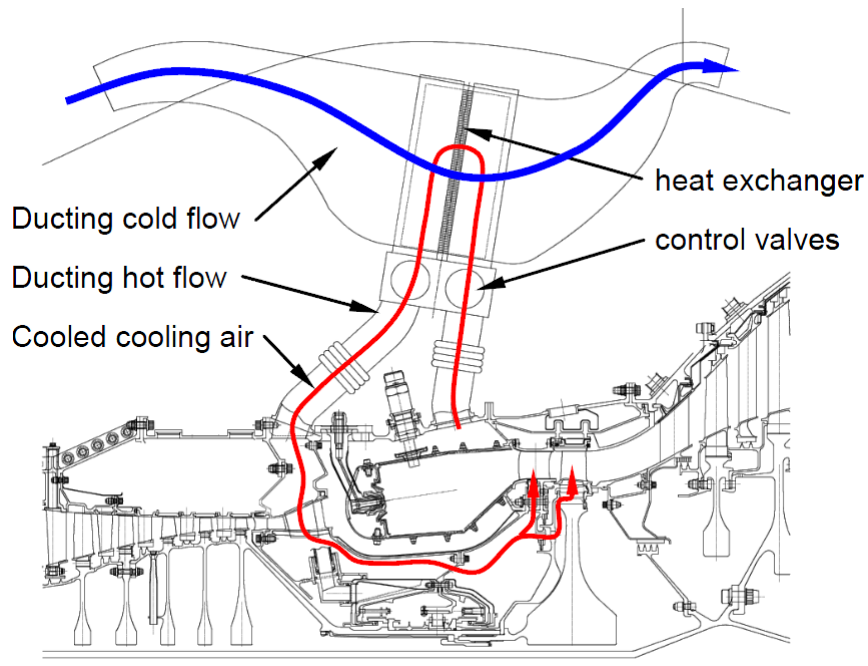

2.1.3 Ambient Conditions

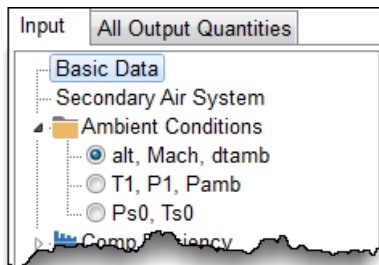

The ambient conditions for aircraft propulsion engines are usually defined by altitude, flight Mach number and the deviation of the ambient temperature from the temperature in the [International Standard Atmosphere](#).

Property	Unit	Value	Comment
Altitude	m	0	
Delta T from ISA	K	0	
Relative Humidity [%]		0	
Mach Number		0	

Use 999 for *Delta T from ISA* to get the ambient temperature of a *Hot Day* and -999 for the *Cold Day* temperature.

If an engine is tested in an altitude test facility then the ambient conditions are described with *Total Temperature T1*, *Total Pressure P1* in front of the engine and the static *Ambient Pressure Pamb* around the exhaust.

Property	Unit	Value	Comment
Total Temperature T1	K	288,15	
Total Pressure P1	kPa	101,325	
Ambient Pressure Pamb	kPa	101,325	
Relative Humidity [%]		0	

The ambient conditions of gas turbines used for power generation are defined by



Property	Unit	Value	Comment
Ambient Pressure Ps0	kPa	101,325	
Ambient Temperature Ts0	K	288,15	
Ambient Relative Humidity [%]		60	
Ref Inl Press Loss(Ps0-P2)/Ps0		0	
Ref Exh Press Loss(Ps8-Ps0)/Ps0		0	
Absolute Inlet Press Loss	kPa	0	
Absolute Exhaust Press Loss	kPa	0	

The reference inlet and exhaust pressure losses are those of the cycle design point. During off-design operation the actual pressure loss deviates from the reference value, it is proportional to the local corrected flow squared. The absolute inlet and exhaust pressure losses are added to the flow dependent losses.

2.1.4 Mass Flow

GasTurb 13 provides special input options that simplify the design of turbofan engine families. There are three alternatives for defining the engine mass flow on offer:

The screenshot shows a tree view on the left with 'Mass Flow Input' selected. Three arrows point from the options 'W2Rstd given', 'W25Rstd given', and 'W25Rstd from HPC Map' to three separate data tables on the right.

Property	Unit	Value	Comment
Inlet Corr. Flow W2Rstd	kg/s	700	

Property	Unit	Value	Comment
HPC Corr. Flow W25Rstd	kg/s	20	

Property	Unit	Value	Comment
rel NH/sqrt(T25/Tstd)		0,95	
Auxiliary Coordinate Beta		0,6	

Select option 1 and you can enter the standard day corrected fan inlet flow W2Rstd. If you select option 2 you can enter the core inlet corrected flow to the high pressure compressor W25Rstd. The fan flow will be calculated from the bypass ratio in this case.

The third option also serves to specify the core flow; it allows you to use a HPC map during design calculations. You specify on the mass flow input page for option number 3 the *Auxiliary Coordinate Beta* and the speed value *rel NH/sqrt(T25/Tstd)* in the HP compressor map. The map is read with these coordinates which yields mass flow, pressure ratio and efficiency of the HP compressor. The flow capacities of the turbines will be calculated in such a way, that the compressor operates at the specified point in the map.

How to use option 3 is described in some detail on the page ["How to Model a Derivative Engine"](#)

2.1.5 Compressor Efficiency

Compressor efficiency can be specified as isentropic or as polytropic value during cycle design point calculations; for off-design calculations the isentropic efficiency is employed. Alternatively the design point efficiency can be *estimated* based on pressure ratio, number of stages, corrected inlet mass flow and a loss correction factor as described in [Reference 3](#).

2.1.6 Turbine Efficiency

The efficiency of an uncooled turbine can be specified as isentropic or polytropic efficiency in an equivalent manner as for compressors. Furthermore, turbine efficiency can be evaluated based on a preliminary [Turbine Design](#) calculation.

If the turbine is cooled, the efficiency definition gets more complicated. GasTurb 13 follows common practice in aero-engine industry and makes the following assumptions:

Multistage turbines are simulated as equivalent single stage turbines. The cooling air for the inlet guide vane of the HP turbine is mixed with the mainstream without any losses. This reduces the burner exit temperature T_4 to the stator outlet temperature (SOT) T_{41} and increases the mass flow through the turbine rotor. The mainstream expands with the specified efficiency and does the work. This results in the turbine exit total pressure P_{44} and the provisional exit total temperature T_{43} . The rotor cooling air does no work and is mixed with the mainstream at the turbine exit. This leads to a temperature drop at constant pressure. The final HP turbine exit conditions are P_{44} and T_{44} .

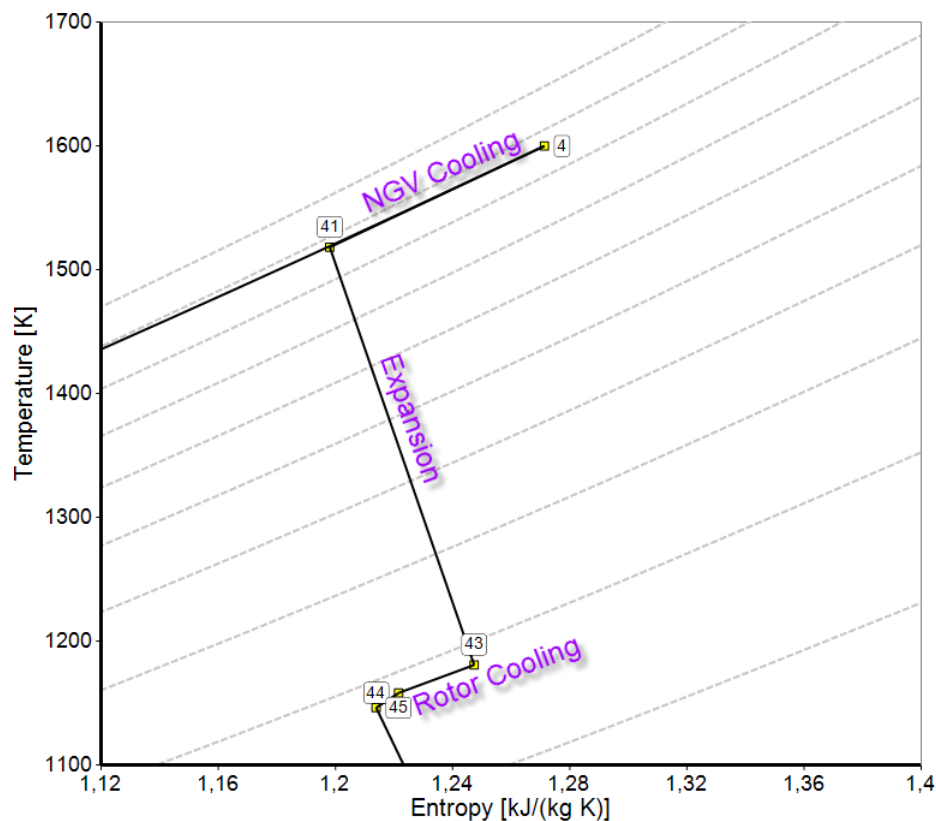

Another way of defining the efficiency of a cooled turbine is described with the following formula:

$$\eta_A = \frac{PW_{SD} + PW_{Pump}}{W_4 \cdot \Delta H_{is} + \sum W_{cooling} \cdot (\Delta H_{is,cooling} + \Delta H_{Pump})}$$

with

- PW_{SD} Shaft power delivered
- PW_{Pump} Power to accelerate the blade cooling air to mean blade circumferential speed
- W_4 Turbine inlet main gas stream
- ΔH_{is} Specific work for an isentropic expansion of the main stream from turbine inlet total pressure to turbine exit total pressure



$\Delta H_{is,cooling}$ Specific work for an expansion of a cooling air stream from the cooling air pressure to the turbine exit total pressure

This sort of turbine efficiency is called the *thermodynamic efficiency* of a cooled turbine

Note that both the efficiency and the amount of cooling air have an effect on the thermodynamic cycle. Be careful when comparing efficiency numbers for cooled turbines because of possible differences in efficiency definition. For getting a feeling for the numbers examine the various efficiency definitions for cooled turbines with GasTurb Details 6.

2.1.7 Conventional Test Analysis

Many measurements are taken while a turbofan engine is on the testbed. Usually the total engine mass flow W_2 is derived from pressure measurements in a bellmouth or in a venturi. The inlet and exit total temperatures and pressures for the compressors are measured. These values allow calculating compressor pressure ratios and efficiencies.

There are two different test analysis methodologies implemented in GasTurb 13. Here is the *conventional test analysis* described and in the off-design simulation section the [model based test analysis](#) is introduced.

In a turbofan, one part of the total mass flow goes into the core engine while, the other part goes into the bypass duct. It is not possible to measure the core or bypass mass flow directly. One has to rely on indirect methods to find the flow split. The analysis can be based on the measured exhaust gas temperature T_5 and the fuel flow, for example. Then the following iteration can be started:

Estimate the bypass ratio and calculate from the measured W_2 the core inlet flow. We know the secondary air system, i.e. the amounts of bleed and cooling air as a percentage of W_{25} . The air mass flow W_3 enters the burner. Now the burner exit temperature T_4 can be calculated because the fuel flow is among the measured values. The turbine inlet pressure P_4 is derived from the measured value of the compressor exit pressure P_3 using standard theory. All information which is needed for calculating HP Turbine corrected flow $W_4^* \sqrt{(T_4)/P_4}$ is available now.

The power required to drive the high-pressure compressor can be derived from the compressor mass flow and the measured total temperatures T_{25} and T_3 . This makes it possible to calculate the high-pressure turbine exit temperature T_{45} . The low-pressure turbine exit temperature T_5 can be determined on the basis of the power balance with the compressors it drives.

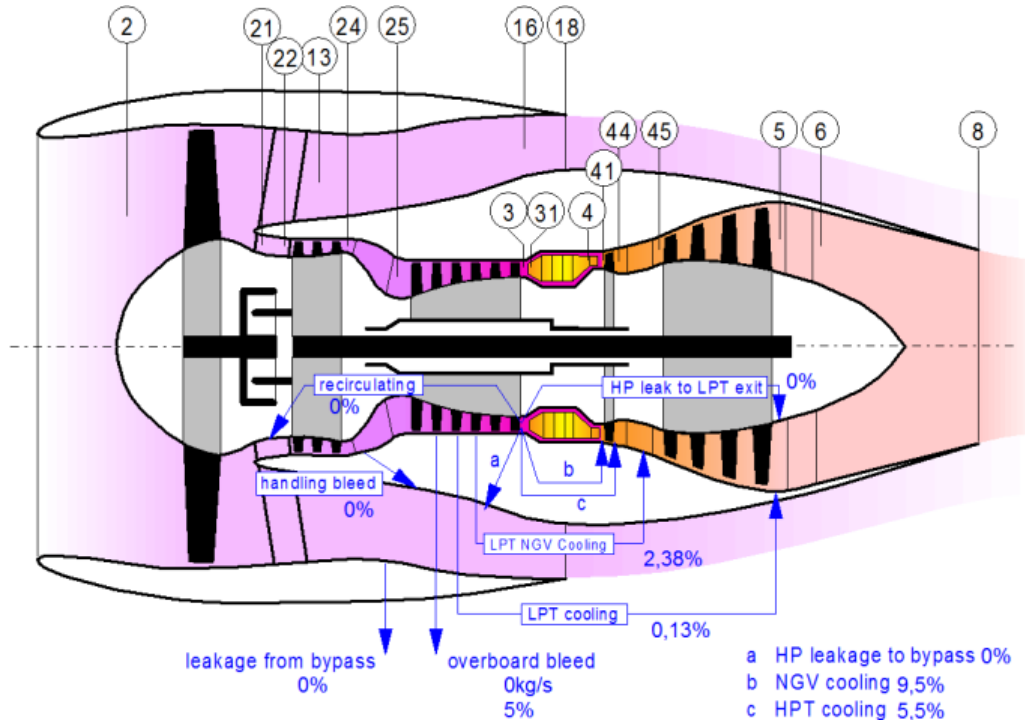

The measured pressures P_{44} and P_5 are employed for evaluating the turbine efficiencies. The power delivered by the low pressure turbine can be calculated from the measurements around the compressors and the core flow.

Now iterate bypass ratio in such a way that the calculated HP turbine flow capacity $W_4 \cdot \sqrt{(T_4)/P_4}$ is equal to a known value. This analysis method is called a *HP Turbine Flow Capacity* method. If you iterate bypass ratio such that the calculated temperature T_5 matches a measured value for T_5 , then you apply the so-called *Heat Balance* method. Similarly you could use the *LPT Flow Capacity* $W_{45} \cdot \sqrt{(T_{45})/P_{45}}$ for finding the core flow.

2.1.8 Test Analysis Example

The conventional test analysis method is in GasTurb 13 implemented as an option for cycle design point calculations:

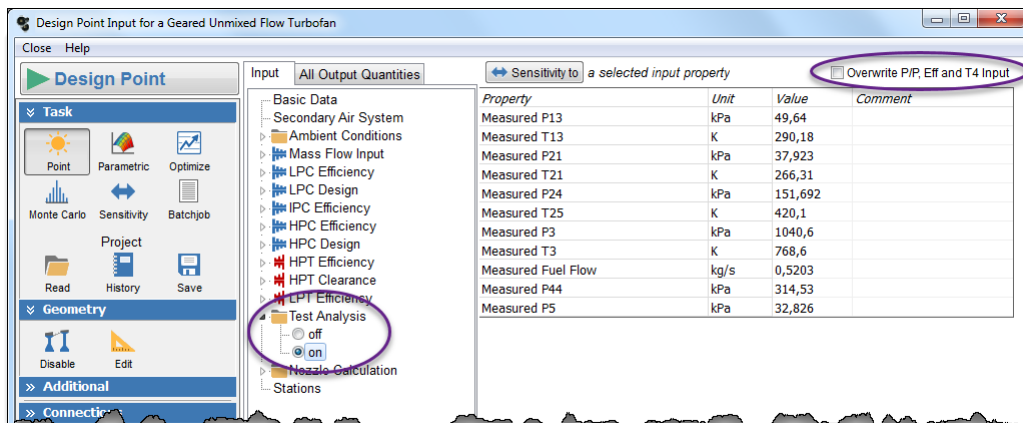

On the *Test Analysis* page in the *Design Point Input* window you can enter measured temperatures, pressures and fuel flow. Other data, like engine inlet conditions, bypass ratio, air system constants and total mass flow W_2 , are entered as usual on the respective pages.

When you run the cycle in the test analysis mode the compressor pressure ratios and efficiencies will be calculated from the measured data. Furthermore, burner exit temperature T_4 , the turbine



temperatures T_{45} and T_5 as well as the turbine flow capacities and efficiencies are found as described in the previous section.

For finding the core flow you need to iterate bypass ratio in such a way that the calculated T_5 matches a measured T_5 or that a calculated turbine flow capacity is equal to a value known from a turbine rig test, for example.

Input quantities that are calculated during test analysis are marked as "a test analysis result" while the test analysis option is selected. By checking the checkbox *Override P/P, Eff and T4 input* you can transfer the calculated data to the normal input and go for off-design simulations with the test derived model of the engine. If you leave the box unchecked, then you dismiss the test analysis result when switching back to normal cycle design calculations.

2.1.9 Reheat

Reheat systems of aircraft gas turbines are also called Afterburners or Augmentors. They can produce a very high specific thrust (thrust per unit mass flow) at the expense of a high fuel consumption.

The screenshot shows a software interface with a tree view on the left and two property tables on the right. The tree view includes categories like Basic Data, Secondary Air System, Ambient Conditions, Comp Efficiency, Comp Design, Turb Efficiency, Tip Clear, Reheat, and Nozzle Selection. Under 'Reheat', there are options for 'Off', 'Input T7', and 'Input T7 or far7'. Two arrows point from the 'Input T7' and 'Input T7 or far7' options to the two tables below.

Property	Unit	Value	Comment
Reheat Exit Temperature	K	1900	
Reheat Design Efficiency		0,9	
Reheat Partload Constant		1,6	
Nozzle Cooling Air Wcl/W6		0,1	
Reheat Design Inlet Mach No.		0,18	

Property	Unit	Value	Comment
Input Reheat Exit Temp	K	2000	
Input Reheat Exit far		0	
Reheat Efficiency		0,9	
Effective Burner Area / A61		1	
Nozzle Cooling Air Wcl / W6		0	
Reheat Design Inl. Mach No.		0,2	

There are two reheat simulation options. For both the *Reheat Exit Temperature* (this is the temperature before the *Nozzle Cooling Air* is mixed with the main stream) can be specified. The second option offers as an additional input alternative the reheat exit fuel-air-ratio.

In the first option the off-design efficiency is calculated from the *Reheat Design Efficiency* value and the *Reheat Partload Constant*. If you intend to do only cycle design calculations then you can ignore the input for this value. Off-design efficiency is calculated using the same algorithm as for the **main combustor**. Since the design point reheat efficiency is usually much lower than the efficiency of the main combustor, the reheat part load constant will also be lower than the burner part load constant.

When using the second option, *Reheat Efficiency* is an input for both design and off-design simulations. Describe with a composed value the dependency of reheat efficiency from temperature, pressure, jet pipe velocity, bypass ratio etc. and iterate *Reheat Efficiency* in such a way that it is equal to this composed value.

The pressure loss in the reheat system is composed of two elements: the dry pressure loss (due to friction etc.) and the heat addition pressure loss. Heat addition in a constant area duct causes the so-called fundamental pressure loss which depends on the inlet Mach number and the total temperature ratio T_{ex}/T_{in} . During cycle design the *Effective Burner Area* is calculated from the *Reheat Design Inlet Mach No.* For this Mach number you should use a rather low value; otherwise the pressure losses due to heat addition become excessive, your reheat exit can even choke and then the cycle calculation will end with an error message.

With the first reheat simulation option the heat addition pressure losses are determined by the given inlet Mach number. In the second option the heat addition pressure losses can additionally be

affected by the ratio *Effective Burner Area A₆₁*. This allows considering jet pipes which are not cylindrical but partially or completely conical.

2.1.10 Nozzle

Most of the engine configurations have [convergent nozzles](#), but for some engines you can select between a convergent and a [convergent-divergent nozzle](#).

For both types of nozzles you can choose between the standard modeling approach (for a detailed description follow the links above) and a user defined empirical model. In the second case the input values are the [gross thrust coefficient](#) and the discharge coefficient. Select these properties as [iteration variables](#) and use as target for these iterations [composed values](#) for employing your special nozzle simulation methodology with GasTurb 13.

2.1.10.1 Convergent Nozzle

The input data for a convergent nozzle are the *Nozzle Thrust Coefficient* and the *Design Nozzle Petal Angle [°]* which has an influence on the [nozzle discharge coefficient](#).

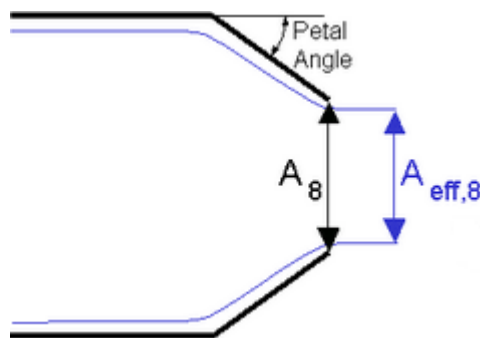

2.1.10.2 Convergent Divergent Nozzle

The geometry of a convergent divergent nozzle is described with the *Design Nozzle Petal Angle [°]* of the primary petals (measured against the nozzle axis) and the area ratio A_9/A_8 .

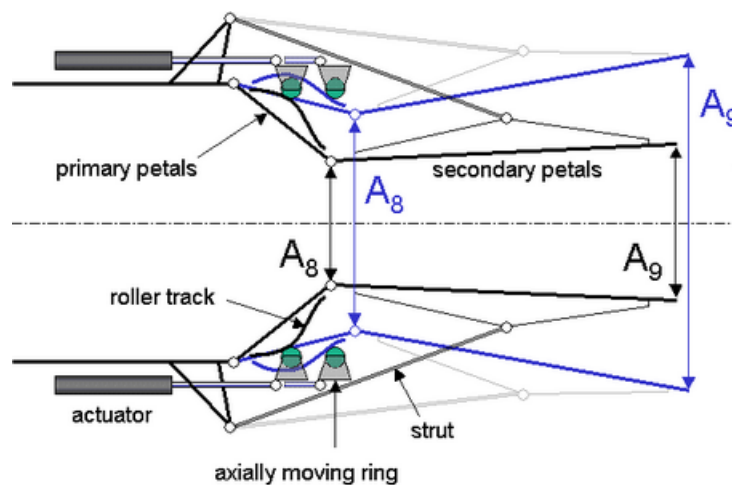

The picture shows a nozzle design in which the throat area A_8 and the area ratio A_9/A_8 change simultaneously when the actuator ring moves. With such a nozzle design only one set of actuators is required, while the independent control of A_8 and A_9/A_8 requires two separately controlled sets of actuators.



To describe a convergent-divergent nozzle with only one set of actuators during off-design simulations the area ratio A_9/A_8 can be made a quadratic function of A_8 .

$$\frac{A_9}{A_8} = a + b \cdot \left(\frac{A_8}{A_{8,ds}} \right) + c \cdot \left(\frac{A_8}{A_{8,ds}} \right)^2$$

If you want to do cycle design point calculations only, then set a to the desired nozzle area ratio and set both b and c to zero.

To achieve a more realistic model behavior for certain nozzle types, the over expansion in the divergent part can be limited by setting the parameter [Limit Over-Expansion](#) to 1.

The [gross thrust coefficient](#) may be used to correct the calculated thrust value.

2.1.10.3 Nozzle Calculation Switch

With the default setting of the *Nozzle Calculation* switch (*Standard*) the nozzle discharge coefficient is calculated from the nozzle petal angle α and the pressure ratio P_9/P_{s8} ([convergent nozzle](#)) respectively from the primary petal angle α alone ([convergent-divergent nozzles](#)).

If you are not happy with the model implemented in GasTurb 13 then you should select *Specify CFG and CD*. Build your own model with the help of composed values and iterate the input values for the discharge and thrust coefficients in such a way that they are equal to the respective composed value.

2.1.11 Thermodynamic Stations

For calculating the thermodynamic cycle of a gas turbine one needs to know only the total pressures and total temperatures at the component boundaries inside of the engine. Static pressures are important only for the exhaust system.

In GasTurb 13 you can specify during cycle design for each thermodynamic station either a Mach number or a flow area. Together with mass flow, gas composition, total pressure and total temperature this yields the flow velocity, static pressure and static temperature. Additionally enthalpy, entropy and other gas properties are determined for each station. The station values can be useful for composed value definitions, for example.

If you do not employ any of the station values in your composed values, then leave the data on the Stations input page at their default value.

For the scope *More...*, however, the input for the stations is very important. The flow areas influence the flow annulus shape and indirectly also the disk design, for example.

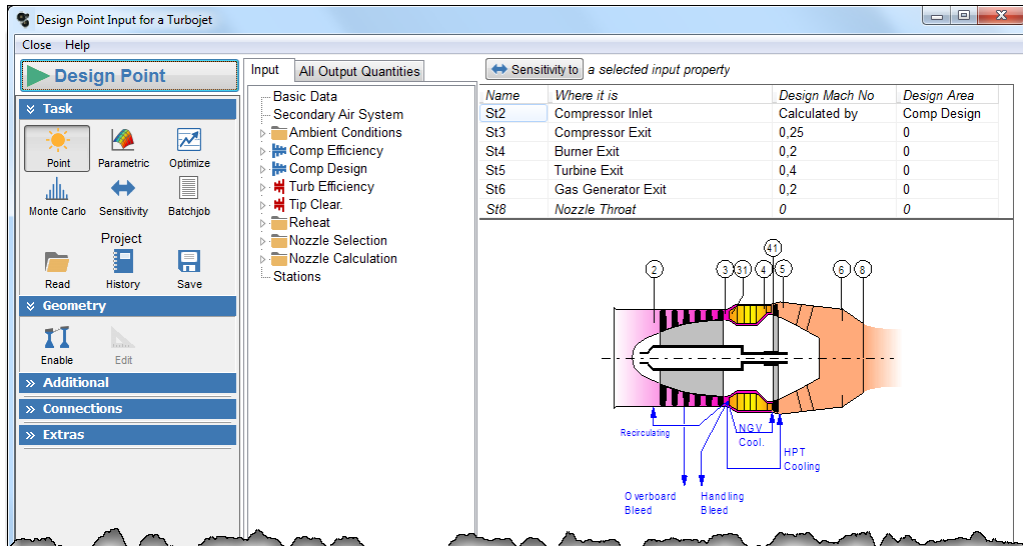

In the example above, for each thermodynamic station, except station 2, you can either specify the *Design Mach No.* or the *Design Area*. The properties of station 2 are no input because **Compressor Design** was selected in this example.

Calculate a single cycle with these settings and you get a table with much detail at the thermodynamic stations:

Summary	Compressor	Air System	Stations	Additional			
	Units	St 2	St 3	St 4	St 5	St 6	St 8
Mass Flow	kg/s	31,68	31,68	28,8571	32,0251	32,0251	32,0251
Total Temperature	K	288,15	630,424	1450	1091,37	1091,37	1091,37
Static Temperature	K	272,247	623,202	1441,46	1064,28	1084,48	939,717
Total Pressure	kPa	100,312	1203,74	1167,63	367,374	360,027	360,027
Static Pressure	kPa	82,2571	1153,48	1137,81	331,04	350,698	194,644
Velocity	m/s	178,633	123,902	146,544	253,857	128,058	598,418
Area	m²	0,168488	0,039654	0,071609	0,11642	0,221985	0,074164
Mach Number		0,54	0,25	0,2	0,4	0,2	0,998985
Density	kg/m³	1,05258	6,44798	2,74989	1,08361	1,12657	0,721593
Spec Heat @ T	J/(kg*K)	1004,52	1058,27	1257,01	1197,09	1197,09	1197,09
Spec Heat @ Ts	J/(kg*K)	1004,13	1056,55	1255,95	1191,66	1195,71	1165,37
Enthalpy @ T	J/kg	-10032,3	341130	1,321426E6	877036	877036	877036
Enthalpy @ Ts	J/kg	-25987,3	333454	1,310686E6	844815	868837	697984
Entropy Function @ T		-0,11924	2,66875	6,14127	4,90935	4,90935	4,90935
Entropy Function @ Ts		-0,317673	2,6261	6,1154	4,80521	4,88309	4,29434
Exergy	J/kg	-831,293	325262	1,015826E6	577682	576010	576010
Gas Constant	J/(kg*K)	287,05	287,05	287,046	287,047	287,047	287,047
Fuel-Air-Ratio		0	0	0,023477	0,021106	0,021106	0,021106
Water-Air-Ratio		0	0	0	0	0	0

Note that all the station properties can be addressed in composed values and special iterations. Moreover, you can plot how selected properties vary along the flow path from station to station after clicking  (*Station Data*) in the Single Point Output window.

2.2 Parametric Studies

The results of parametric studies are presented as graphics which can be composed from all calculated quantities. The single cycle design point, which was calculated before the parametric study was selected, is shown in the graphs as a reference point. If this point is not consistent with your parametric study then you should hide it. This can be achieved by clicking  (*Reference Point*).

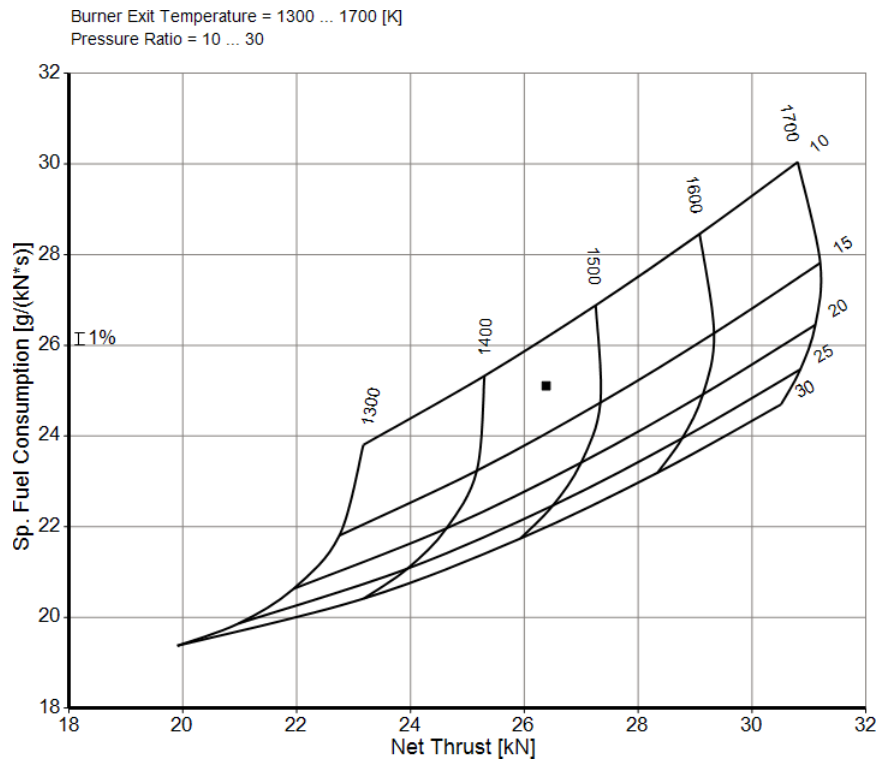

Each time you click (*Arrange*) then the numbers describing the parameter values are placed differently. Repeated selection of this option will cycle through all possible arrangements including a picture without the parameter values. This will allow you to find the best position for the text.

Parametric variations with up to 49 steps of one or two variables are possible. For the second parameter you can choose instead of a cycle input property also two or more different types of fuel like JP-4 or Natural Gas. In such a parametric study for each fuel the nominal fuel heating value (that is the one which you get if you enter zero as fuel heating value in the single point input) is employed.

You can add so-called contour lines to any plot with two parameters, i.e. lines along which a selected output property is constant. While you are performing cycle design studies you can select properties from the cycle design calculation or from an off-design calculation, provided this was defined as a *mission* point before initiating the parametric study.

Selected input and output properties can be [written to a file](#) or exported to Excel.

2.2.1 Parametric Study with Iteration

With a TWO SPOOL UNMIXED FLOW TURBOFAN you may perform a parametric study with *HP Compressor Pressure Ratio* and *Burner Exit Temperature* as parameters. Since in such an exercise the *Outer Fan Pressure Ratio* remains constant one does not get the best possible relation between the core and bypass nozzle exit velocities.

To correct that deficiency of the parametric study you can *iterate* the *Outer Fan Pressure Ratio* in such a way that the two nozzle jet velocities are in a fixed relation with each other. Select as iteration variable the *Outer Fan Pressure Ratio* (min=1.1, max=4) and as iteration target that the *Ideal Jet Velocity Ratio Vid,18/Vid,8* shall be equal to 0.8 which is near to the thermodynamic optimum.

If you encounter convergence problems then it might help to exchange the parameter sequence or you can begin the parametric with the highest value and then decrease it successively with negative steps.

2.2.2 Companions

For some parametric studies, it is desirable to vary several input properties simultaneously. An example would be the *Burner Exit Temperature*, the variation of which is typically accompanied by changes in the amount of cooling air and the polytropic efficiency of the HPT.

In GasTurb 13 this can be achieved by defining *Companions* in the *Parameter Selection* window. They are varied in parallel to the first parameter of the parametric study, within definable Start and End values.

The *Companions* are invisible by default and must be shown first by clicking the button *Visible* in the Companions section on the left. Then, up to five Companions can be defined by means of drag and drop. The desired parameter must be selected from the list, dragged above the grey label Undefined and then be released. Next, start and end values can be prescribed. The reference value at the design point is shown with no frame on the right. Once Companions are defined, they will automatically be varied once the parametric study is executed. An example of companion definition is shown in the next figure.

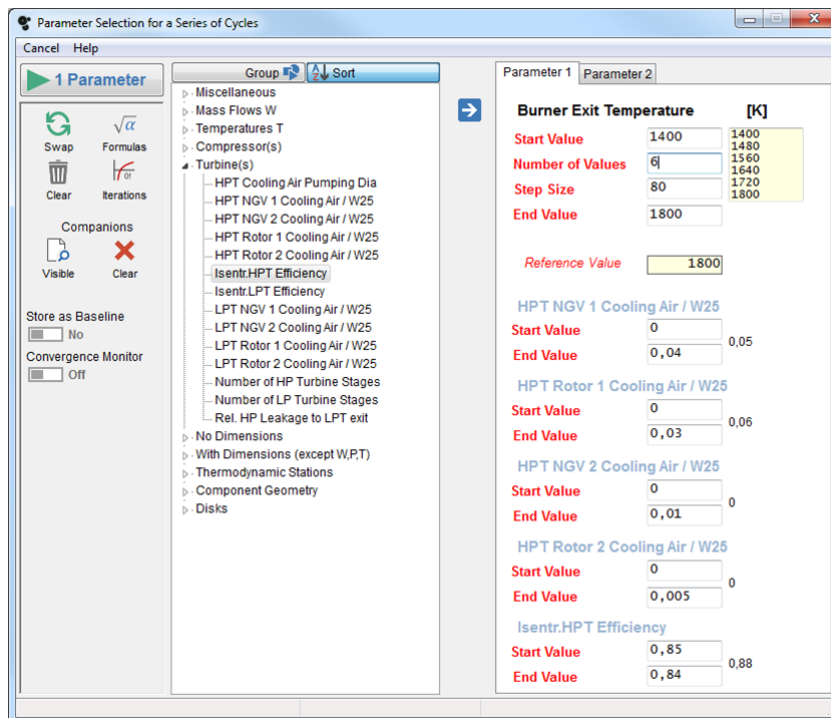

To delete the *Companions*, the button *Clear* in the Companions section on the left must be used.

Other useful applications of *Companions* include:

- Varying the efficiencies of several compressors or turbines simultaneously
- Varying compressor design pressure ratios in parallel to study the effect of overall pressure ratio changes
- Simulating a climb by changing altitude and Mach number in combination



2.2.3 Contours and Boundaries

The following pictures have been created with a parametric study for a TURBOJET in cycle design mode. The parameters are *Pressure Ratio* = 10...30 (5 steps, step size 5) and *Burner Exit Temperature* = 1300...1700 [K] (5 steps, step size=100). The default plot parameters are *Sp. Fuel Consumption* and *Net Thrust*. To add more content to the picture, select from the tree view *Nozzle Throat Temperature* and drag it to the box on the *Contours* page. Furthermore, drag *Turbine Pressure Ratio* to the top left box on the *Boundaries* page and set as value 5.

Draw the picture by clicking the *Draw y=f(x)* button.

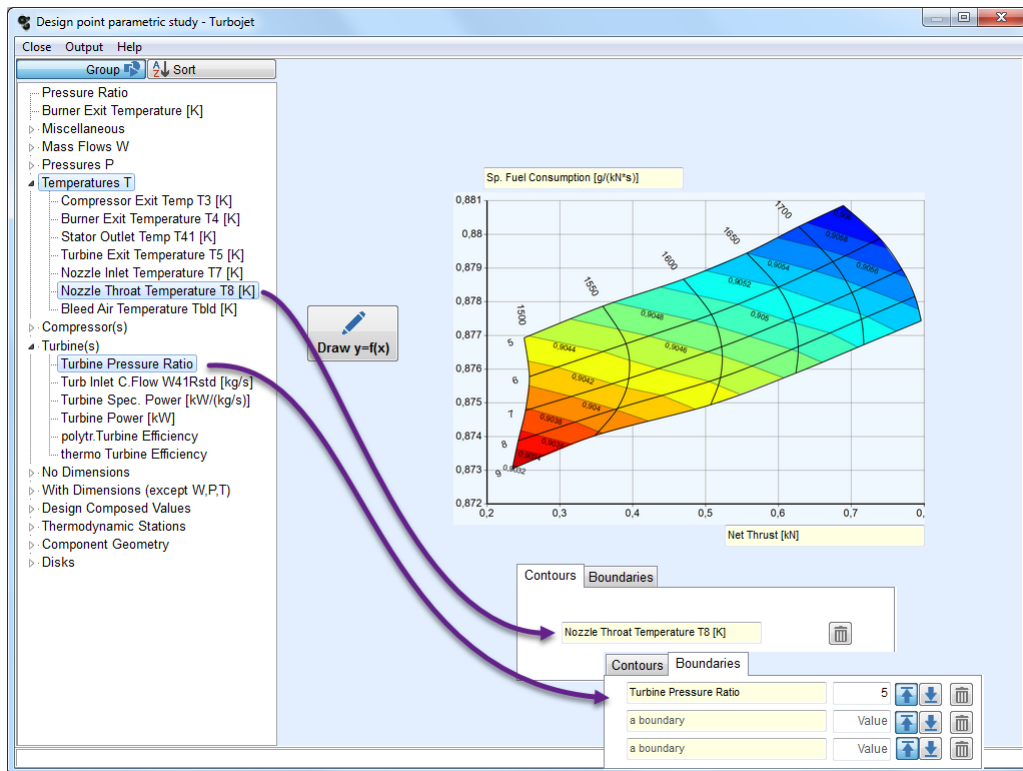

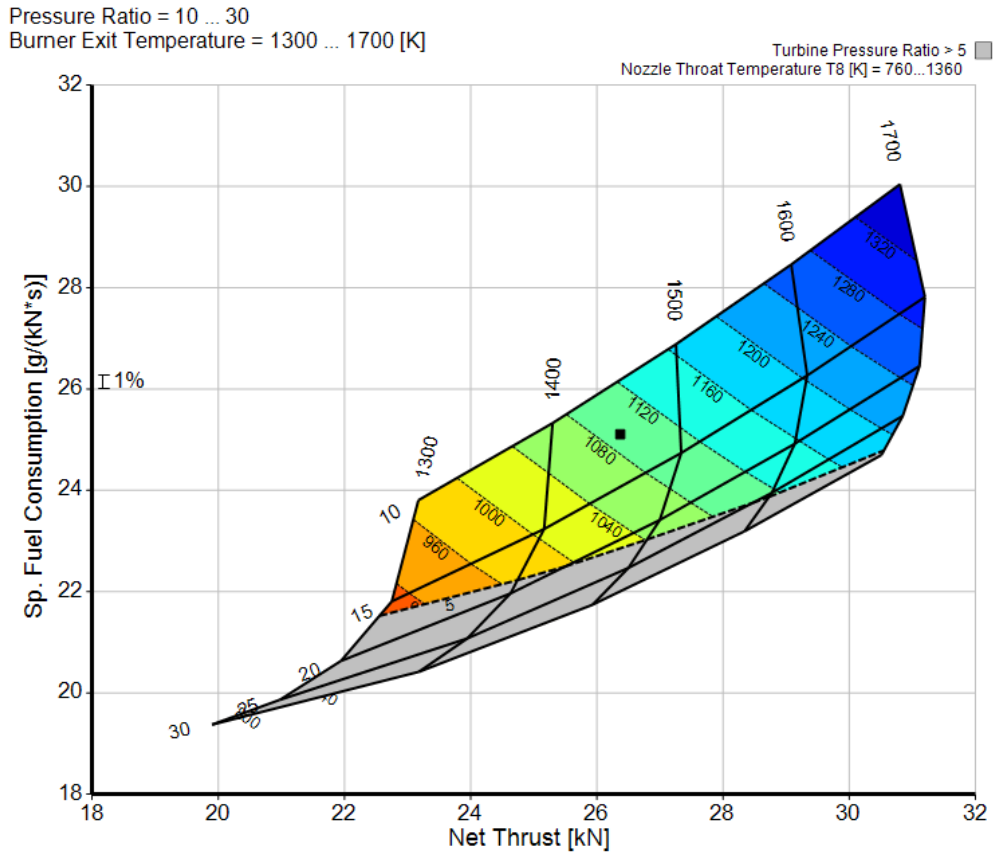

2.2.4 Picture Overlay

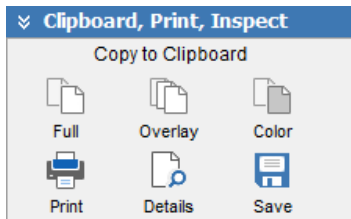

Any GasTurb 13 picture can be copied to the windows clipboard and then pasted into Power Point, for example. Moreover, if you create a series of picture which all have the same scales on the x and y-axis, you can combine them on a single Power Point page. This is how it works:

In GasTurb, after having calculated the first picture, choose *Copy to Clipboard* and then paste the picture to Power Point. Go back to the GasTurb data input window, change the Mach Number, for example, and run the parametric study again. Adapt the x- and y-axis scales to make them consistent with the axes from the first picture. Click the *Copy as Overlay* or the *Overlay in Special Color* button to copy the contents of the picture to the clipboard.

Plot titles, x-and y-axis are not part of an overlay copy. The axes are replaced by little markers for the begin and the end of the respective axis. Paste the overlay to the same Power Point page on which the first picture resides and move the overlay to the position where the four little markers are in line with the ends of the x- and y-axis. Add some text to explain the added carpet. The picture below is composed from a baseline picture for Mach=0 and two additional carpets for Mach=0.3 and Mach=0.6

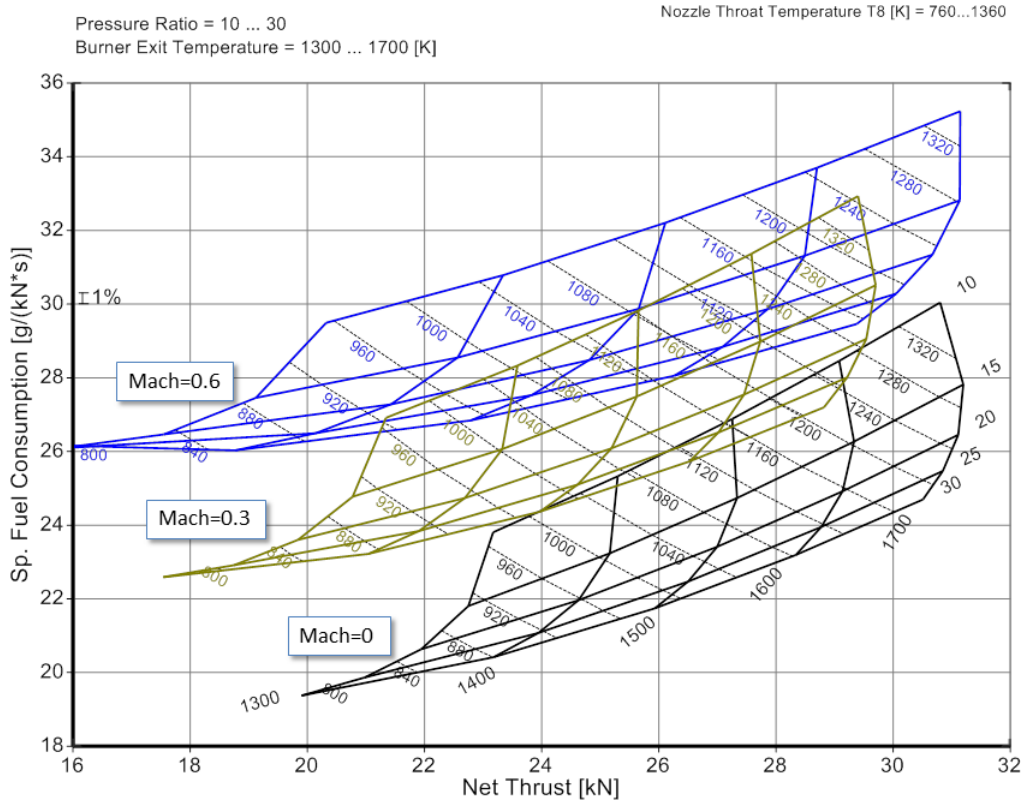

2.2.5 Combining Design and Off-Design Results

During a cycle design parametric study you can consider the properties from several off-design points into account. To do that, go to the *Off-Design Input* window and define a *mission* with one or more points.

		Point 1	Point 2
Show Result		yes	yes
Description		dTamb=20K	dTamb=-20K
Altitude	m	0	0
Delta T from ISA	K	20	-20
Relative Humidity [%]		0	0
Mach Number		0	0
Intake Pressure Ratio		0,99	0,99
Fuel Heating Value	MJ/kg	43,124	43,124
Compressor Bleed			

Then go back to the *Cycle Design Input* window and run the parametric study. For each point the complete mission will be calculated. Now you get the choice to plot the properties from the design point or from one of the mission points.

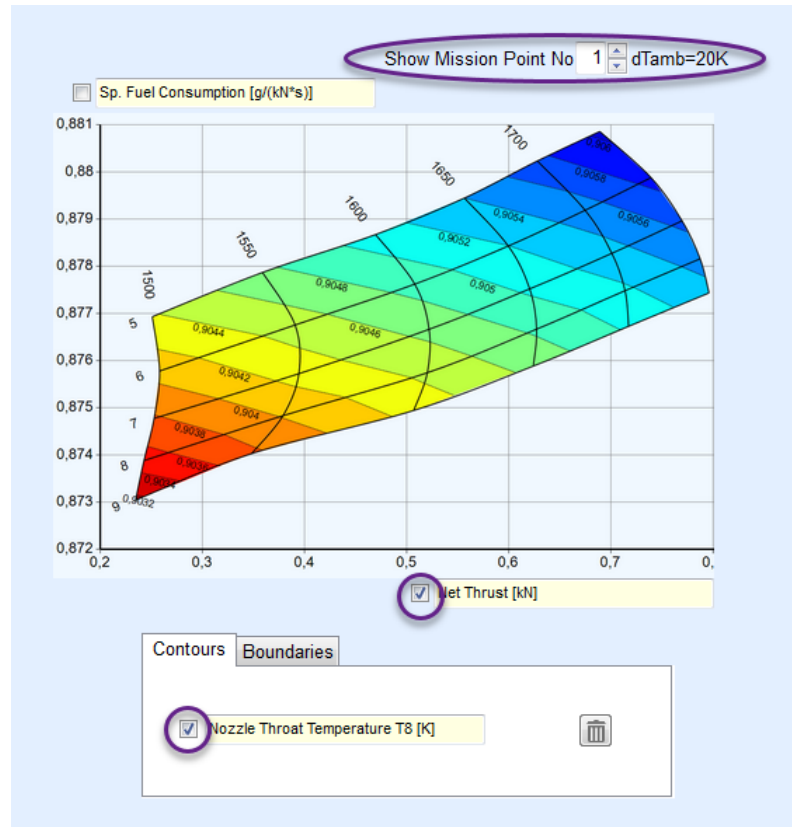

2.2.6 Difference Between Two Parametric Studies

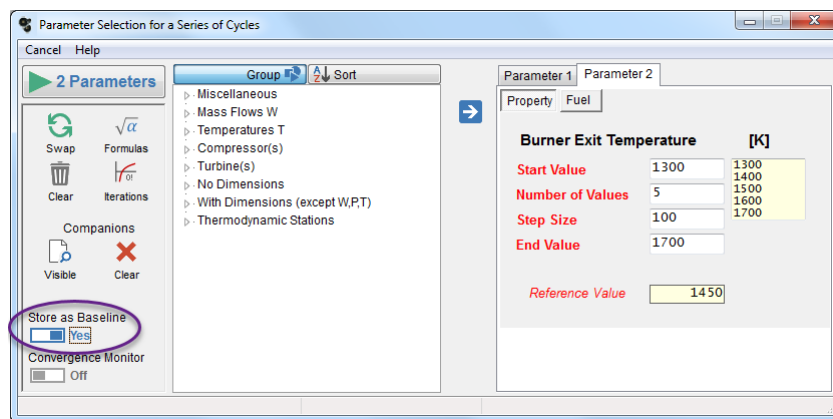

For comparing the results from two parametric studies with the same parameter selection perform first a baseline parametric study. Then go back to the *Design Point Input* window, adapt the input data, and then run the parametric study again. Do not modify any data in the parameter selection window because this would erase the reference data that were stored before.

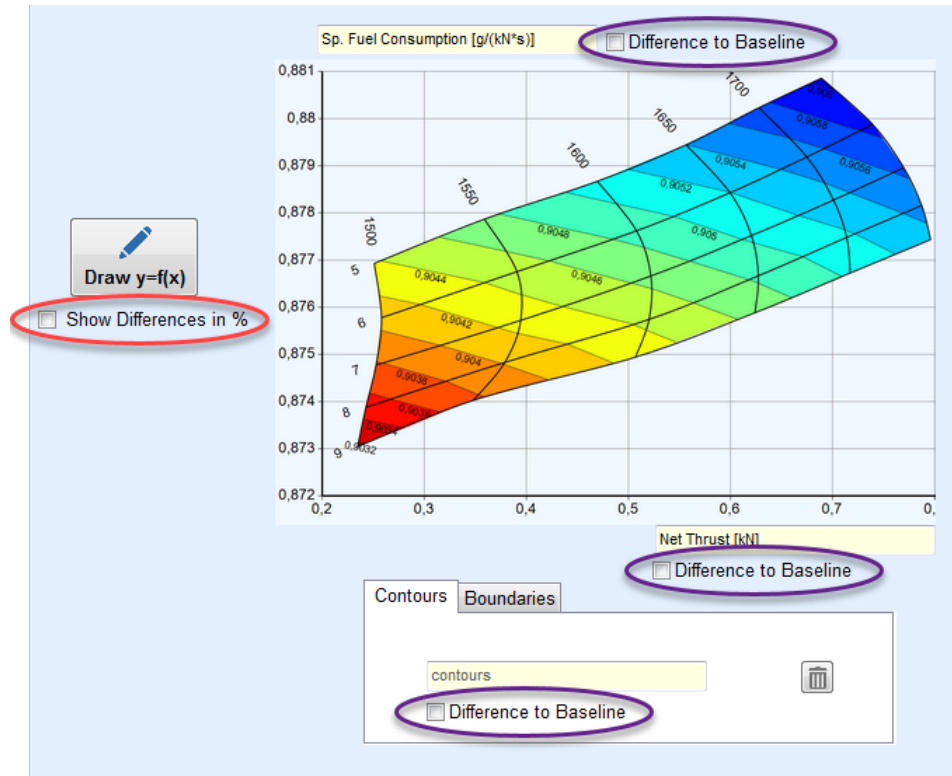

When the parametric run is completed, the plot parameter selection window opens again, but now with additional checkboxes. When these boxes are checked, then instead of the result from the last parametric study the difference between the last result and the baseline is shown in the graphic. Check *Show differences in %* if you prefer percentage values over absolute differences.

2.3 Cycle Optimization

For a cycle optimization you can select up to 12 [optimization variables](#) and set up to 12 [constraints](#) on output quantities. Any cycle output parameter, including the composed values, can be selected as a figure of merit that you can either maximize (specific thrust, for example) or minimize (such as specific fuel consumption). You can also combine optimization with iteration.

In addition to the properties of the cycle design point you can consider several off-design operating points which are defined in a [mission](#). The data from the mission points can be [constraints](#) and they can be employed as [figure of merit](#).

You can begin the optimization process with the [adaptive random search](#) strategy, for example. In the upper part of the optimization window you see, on the left side, gauges that indicate the values for the variables, and on the right side, gauges for the constraints. A chart below the gauges shows the progress of the optimization with respect to the figure of merit. The *max FOM* and *min FOM* inputs allow you to change the scale in the progress indicator chart. If you don't see any points in the chart during an optimization run, then click the *Scale* button

As soon as the optimization run is finished, you should check whether the optimum is local or global. Select *Random*, *Newstart*, to begin a random search moving away from the present optimum, followed by a new search for the optimum. If you get always the same result then you can be sure that you have found the global optimum. If you get from each optimization run a different result, then try the *Endless Random* strategy.

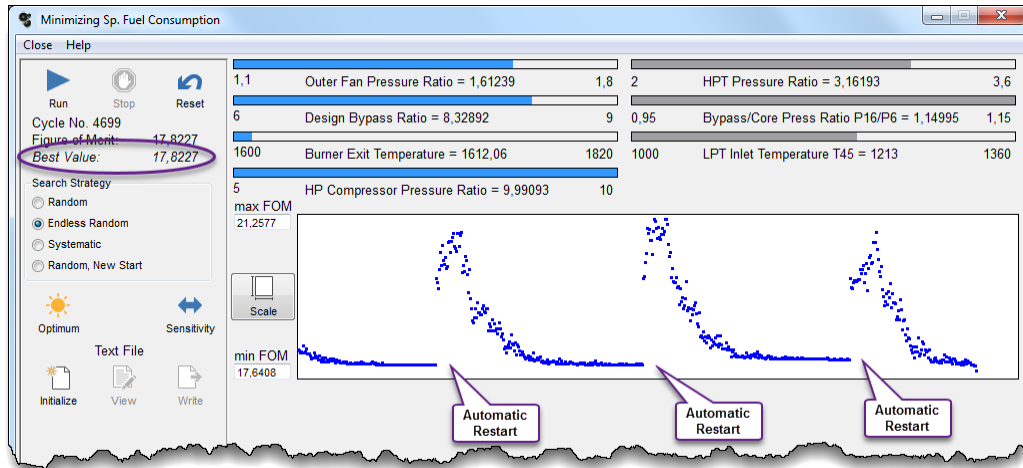

In the figure above you see what happens with this strategy: after finding an optimum, the search is automatically restarted. The best solution found in all optimization attempts is the final solution of the optimization.

Alternatively to the random search strategy, you can select the *Systematic* strategy which is a [gradient search](#).

2.3.1 Optimization Variables

The numerical optimization allows you to define up to 12 optimization variables. Be careful with the input data for the optimization: both the lower and the upper limits for the optimization variables have to be selected properly. If you restrain the range too much the solution will be found on the limits and you will have to reset them. If the range for the optimization variables is too broad, many variable combinations will be physically meaningless.

The start values of the optimization variables should be within the specified range and the cycle results should fulfill all constraints. When your starting point is outside of the feasible region then the program will try to find a valid cycle. This attempt, however, is not always successful.

2.3.2 Constraints

The numerical optimization allows you to define up to 12 constraints for any of the output variables. You can answer questions like the following with optimization:

Optimize pressure ratio and burner exit temperature of a turbojet in such a way, that the specific fuel consumption is minimized with the constraints:

- the design turbine pressure ratio must be lower than 4.
- the turbine exit temperature must be not higher than 1000K.

Note that the composed values can also be employed as constraints. Use them to describe specific design limits that are applicable to your special example.



2.3.3 Off-Design Constraints

The sizing of an engine for a subsonic transport aircraft is generally done for an aerodynamic design point at high altitude. For such a flight condition one gets usually high Mach numbers at the compressor inlet, but rather moderate turbine inlet temperatures.

The maximum turbine inlet temperature will occur at hot day Take Off conditions. From a cycle design point of view this is an off-design case.

During a cycle design optimization exercise you can take constraints from many off-design points into account. Define a [mission](#) for that purpose before initiating the optimization. Then you will have for each of the 12 constraints the choice, whether it applies to the design point or to one of the off-design points.

2.3.4 Figure of Merit

The figure of merit can be a single property (like the specific fuel consumption which shall be minimized) or a composed value which takes more than one property into account. If in addition to the cycle design point off-design points from a mission are considered as part of the optimization exercise, then the figure of merit can be either a design point property, an off-design property or the sum of a design and an off-design property.

2.4 Sensitivity Studies

You may often want to know how important one of the input quantities is for a certain cycle. This option has already been described in the *Getting Started* section. Remember that you can use the pre-defined step sizes or enter your own numbers for each input variable step. Remember also that you can combine this type of calculation with the iteration option and look at the changes of any [composed value](#) you have defined. In this way, you can produce a table with concise information about the most important parameters in your problem.

Note that the effects of small changes of the same variable can be quite different for cycle design and off-design cases.

2.5 Monte Carlo Study

The Monte Carlo simulation method calculates many cycles in which some selected cycle input parameters are randomly distributed. The cycle output quantities will consequently also be randomly distributed. [Normal distributions](#) with specified standard deviation or [asymmetric distributions](#) will be created for the selected input parameters. The results are presented graphically as bar charts together with points that indicate the shape of a corresponding Gaussian distribution.

You can export the results from a Monte Carlo simulation to [Excel](#) and do there more statistical analysis.

2.5.1 Engine Design Uncertainty

Uncertainty during engine development accounts for the possibility that the designer will not exactly achieve the design intent. There is a distribution of possible performance levels associated with a component's performance rather than a discrete value. The distribution is not symmetrical – not a Gaussian distribution – and therefore the use of the [Root-Sum-Squared](#) method is not adequate.

Uncertainty in component technology can be modeled in a probabilistic fashion. The data on variability can be collected by asking the component design experts three simple questions:

What is the predicted value?

Assume that the predicted value is also the most likely value.

What are the one-chance-in-a-thousand best and worst possible values?

Most people can relate to this as unlikely chance, but a chance nonetheless. For modeling purposes, these values can be used as the 0% respectively 100% probability values.

If you did ten such designs, how many of them would fall within an interval of the width x ?

Provides additional confidence information.

GasTurb 13 must be operated in cycle design mode while doing simulations with the aim of finding a number for the development risk.

2.5.2 Test Analysis Uncertainty

The evaluation of the component efficiencies from an engine test is an indirect process. The uncertainty of the result depends on the uncertainty of the measured quantities like pressures, temperatures, fuel flow and spool speeds.

The uncertainty of the test analysis process can be evaluated with a Monte Carlo simulation. For each of the probes, and the engine build measurements like turbine flow capacities and nozzle areas, there are tolerances. The same is true for the secondary air system which is assumed to be known during the test analysis process.

For a proper uncertainty analysis all the elements that influence the test result shall be listed. For each item on the list the uncertainty must be quantified and agreed on with the specialists. In many cases the uncertainty can be expressed with the standard deviation of a Gaussian distribution. However, there are exceptions: measuring a pressure on the high side is less probable than measuring it on the low side because a small leak in the pipe between the rake and the actual sensor will always decrease the indicated value.

The items in the list constitute the input for the Monte Carlo study into the test analysis program. Once the uncertainty of all elements has been agreed on between all stake holders, the Monte Carlo study can be run. The result will be the standard deviation for the properties of interest like the component efficiencies.

Since the analysis results depend not only on the measurement uncertainty but also on the core flow analysis method, a Monte Carlo study will also yield information for the selection of the method with the least uncertainty in the result.



2.6 External Load

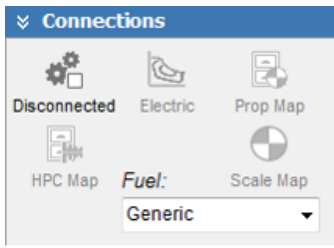
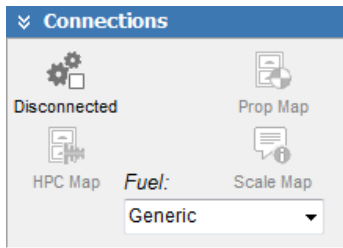

An *External Load* can be connected with any spool for all engine configurations. The load may be a [single specified value](#), a [lift fan](#) or a [load compressor](#).

The calculation sequence is such that the *External Load* calculations are done before the gas turbine cycle calculations.

If you want that the load itself or a property which affects the load is in a certain correlation with the properties of the gas turbine then you need an iteration.

For example, if the *Lift Fan Inlet Temperature* and *Lift Fan Inlet Pressure* are the same as the engine inlet conditions then these two properties must be variables in an iteration in which the target values are the engine inlet temperature T_2 and engine inlet pressure P_2 . Transient simulations and test analysis by synthesis are not possible while an external load is connected to the engine.

2.6.1 Power Offtake from Any Spool

The most simple case of an external load is connecting a constant load with an engine. The input value for this load may be iterated in such a way that it is equal to the result of a [composed value](#).

2.6.2 Lift Fan

The lift fan produces thrust which can be controlled by variable guide vanes and the variable lift fan exhaust nozzle area.

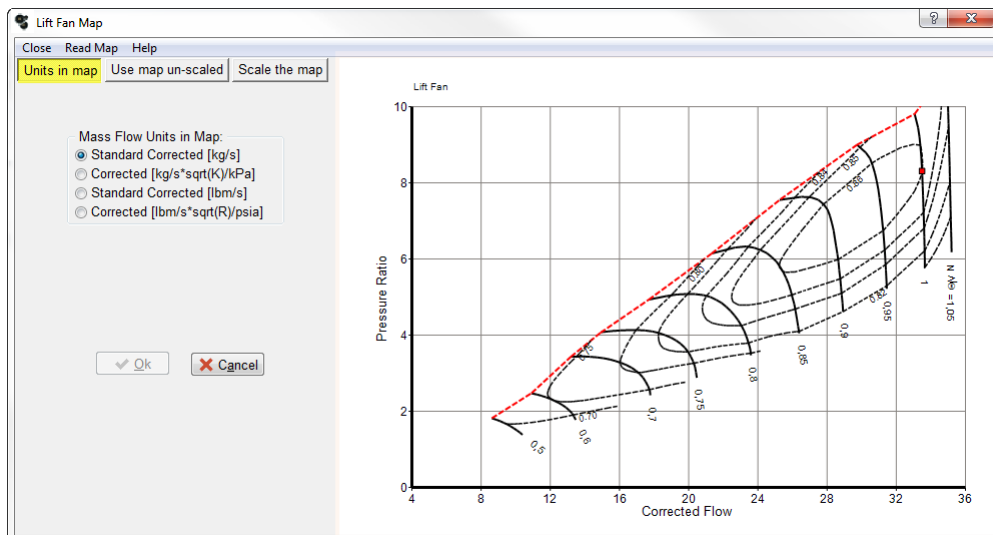

A map for the lift fan must be loaded for the cycle design calculation with external load. You can use an unscaled map or scale a map according to your requirements. Note that no Reynolds corrections are applied to the lift fan map. You must decide if you want to use the map unscaled or scaled. In the unscaled map you can position the operating point by setting the *Design Map Speed* and *Design Map Beta*. The corresponding values for mass flow, efficiency and pressure ratio are shown in the box on the lower left side.

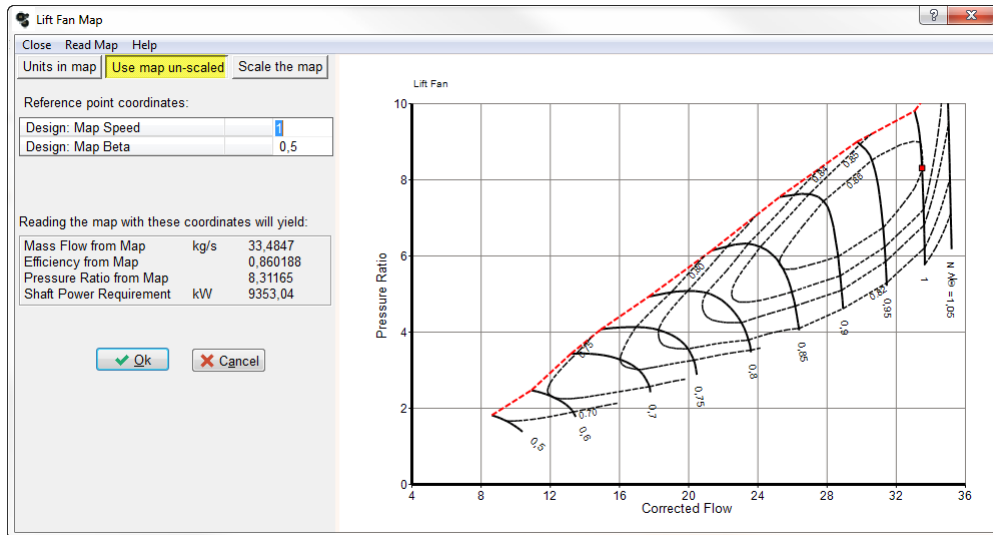

If you choose to scale the map, then you can input both the map coordinates and true values for mass flow, efficiency and pressure ratio. The resulting map scaling factors are shown on the lower left side.

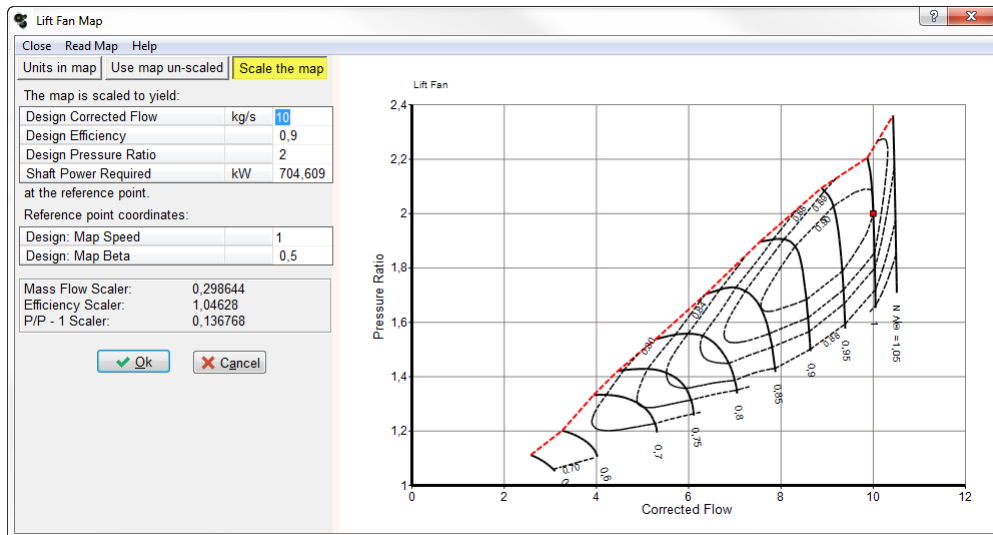

2.6.3 Load Compressor

The load compressor model includes variable guide vanes but no nozzle simulation. Attach a load compressor to a single or two spool turboshaft to simulate an aircraft auxiliary power unit (APU).

A map for the load compressor must be loaded for the cycle design calculation with external load. You can use an un-scaled map or scale a map according to your requirements. Note that no Reynolds corrections are applied to the load compressor map.

Initializing the load compressor map is similar to initializing the [lift fan map](#) as described in the previous section.

Geometrical Engine Design

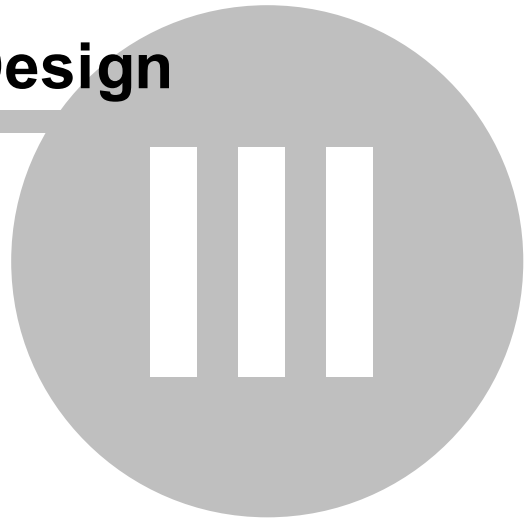





3 Geometrical Engine Design

3.1 Overview

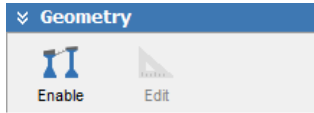
Engine dimensions are calculated for each cycle design point if you select in the program opening window the scope "More".



Drawing the engine cross section requires additional input data that are described in the following sections component by component. For editing the geometry input data, click in the *Geometry* button group on  (*Enable*).

Local Mach numbers (or flow areas) are the design point input data for the main [Thermodynamic Stations](#). From the cycle data mass flow, total pressure and total temperature are known, a given Mach number allows to calculate the flow area for each station if it is not given as input quantity.

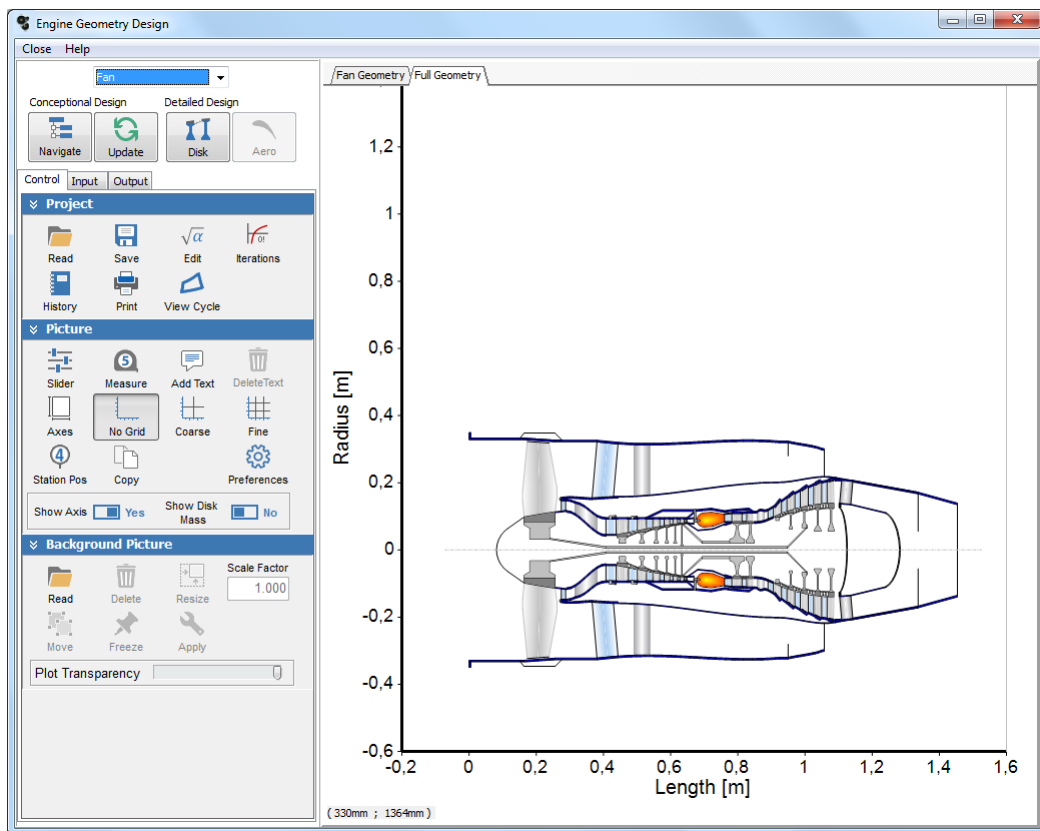

With the cross section on the screen you can zoom in to see some details more clearly. Zooming into an engine cross section behaves differently compared to zooming into other graphics of GasTurb because for cross sections the scales of both x and y axes (length and radial axes) must be the same. In GasTurb 13, the axis can be hidden by means of the *Show Axis* switch. They are then replaced by a scale, which is displayed instead. Once the axis are hidden, the sketch can also be navigated by pressing the *CTRL* key and moving the picture with the mouse.

Note that many details of a real engine are not modeled explicitly in GasTurb 13; therefore the calculated mass (weight) numbers are always on the low side.

During off-design simulations you can view the engine dimensions and the disk stresses at the given operating condition, however, you can not modify the engine geometry in off-design mode. The only exception to this are the disks that can also be modified in off-design mode. This facilitates disk design, which is usually not done for the same operating point as flow path design. Remember, when doing [parametric cycle design](#) studies or [cycle optimization](#) studies, you can consider in addition to

the design point properties also properties from off-design operating conditions which are defined in a [mission](#). This might be the stress margin in the most critical disk of your engine, for example.

3.2 Engine Design Example

When you click the  (*Edit*) button for the first time after loading one of your own data sets (as opposed to the demo files) then you will get an engine drawing which does not look perfect at all. The reason for that is, that the default input data for the *Thermodynamic Stations* and the geometry are not good enough for your specific engine design. How do you get a more reasonable engine drawing?

Let us have a look at the design of a [2 Spool Turbofan](#) as an example, beginning with the data from the file **Demo_tf.CYF**:

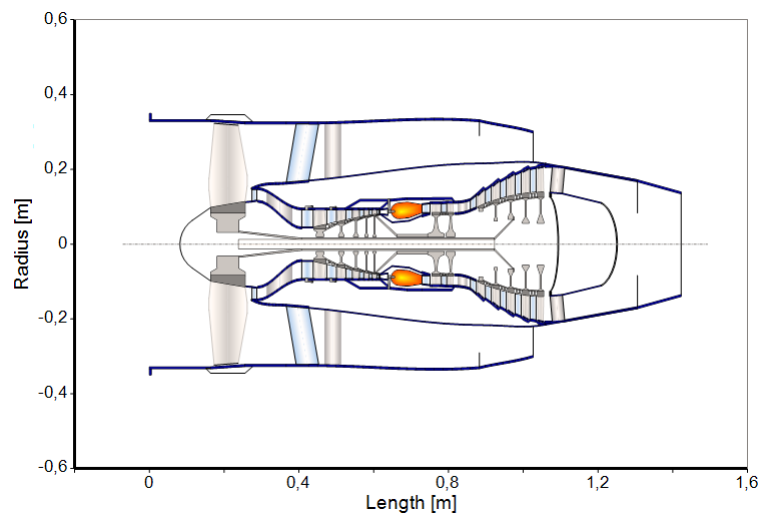

First we deal with the [flow annulus](#), second with the [disk dimensions](#).

Note that you can load as [background](#) for the drawing of the calculated engine geometry a cross cut picture of a real engine (as a bitmap). This makes it easy to match the model to the geometry of the real engine. Note that the background picture will not be printed and not be copied to the clipboard.

3.3 Flow Annulus

3.3.1 Compressors

We will now examine the [flow annulus](#) created from the data **Demo_tf.CYF** beginning with the LPC (the fan). Select the *Fan* in the box on the left and open the *Input* tab sheet. You will see that the hub-tip *Inlet Radius Ratio* is 0.3. Change it to 0.5 and press *Enter* or the click the *Update* button to refresh the geometry calculation. The results will be displayed in the *Fan Geometry* tab on the right. Select the *Full Geometry* tab to display the whole engine sketch.

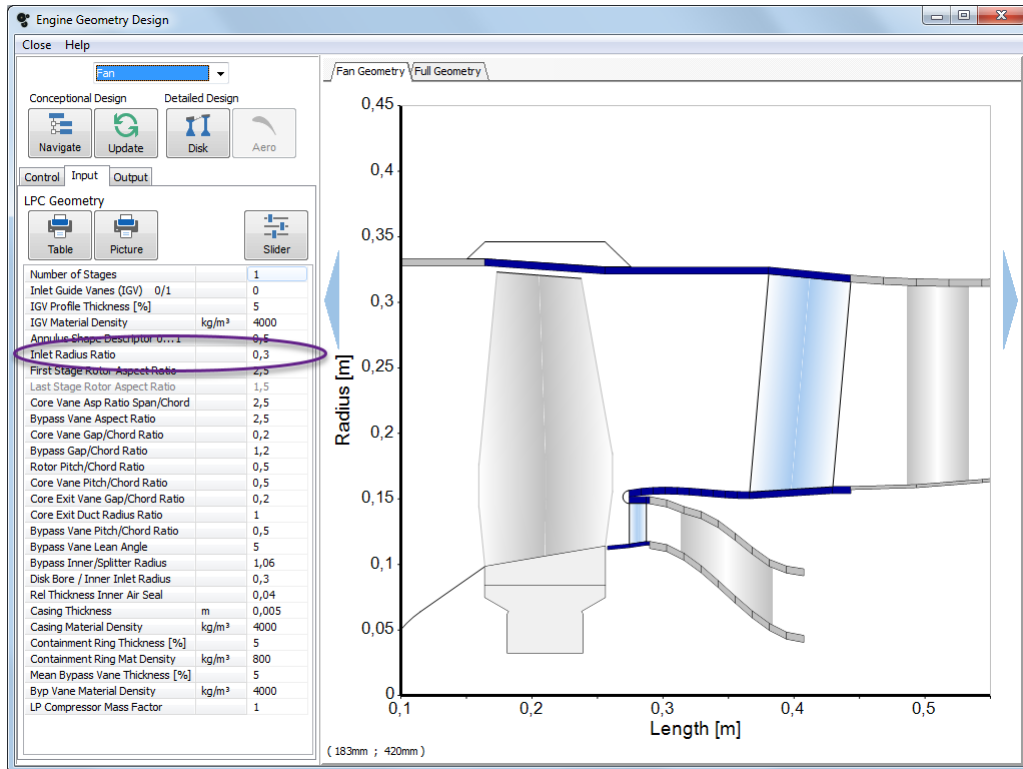

You will see a dramatic change in the fan dimensions as well as the compressor inter-duct which connects the LPC with the HPC. Comparing the LPC shapes with various *Inlet Radius Ratio* values this way are easy, however, one can do better: Assign the *Inlet Radius Ratio* to a slider: click *Slider* in the *Input* tab sheet.

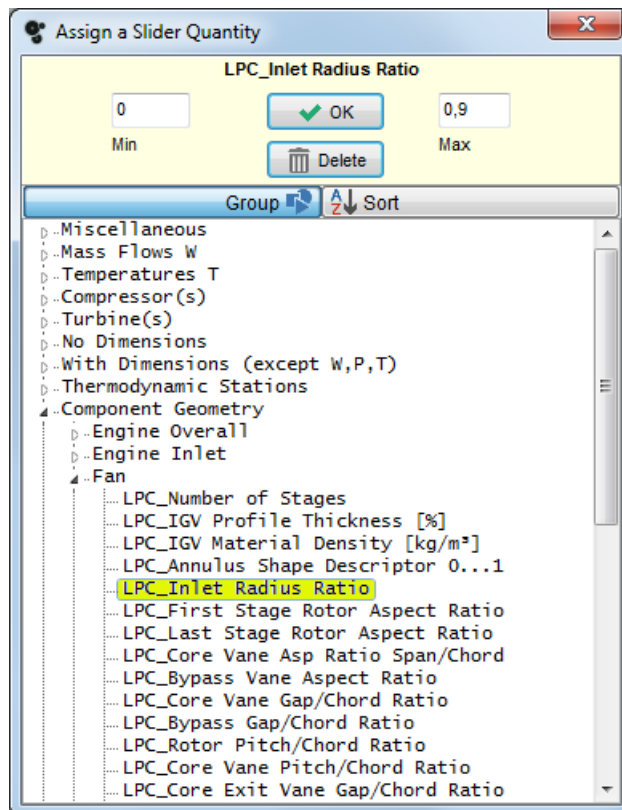

Now you can modify the LPC *Inlet Radius Ratio* and directly observe the effect on the drawing. When you are done with your slider experiments reset the *Inlet Radius Ratio* to 0.3 manually or reload the

data file Demo_tf.CYF from the cycle *Design Point Input* window. Next assign the *Design Mach Number* at station 2 to a slider and see, that also this variable has a big influence on the LPC shape and the overall engine dimensions.

Note that you can select - besides the *Component Geometry* input data and those for the *Thermodynamic Stations* any of the cycle input data. After each slider movement not only the geometry calculation will be repeated, the complete cycle is refreshed.

Another option for setting the LPC dimensions is to select **LPC Design** in the *Design Point Input* window. This yields not only the data of the thermodynamic station 2 but also the low pressure spool speed which is most important for the disk stress calculation. While *LPC Design* is selected the *Inlet Radius Ratio* on the *LPC* page cannot be edited because this quantity comes now from the *LPC Design* page in the *Design Point Input* window.

After examining how the various input data affect the LPC geometry switch to the HPC and study some more options. A slider for the *Annulus Shape Descriptor* can be found in the *Control* tab sheet. Vary it and observe its effect on the flow annulus. On the *Input* tab sheet, try also assigning the *First Stage Aspect Ratio* and the *Last Stage Aspect Ratio* to a slider and see that these values are dominant influence factors for the compressor length.

3.3.2 Turbines

The turbine inlet radii are a result of the calculations done for the upstream component. Therefore - if you want to modify the turbine inlet geometry - you must work with the input of either the burner (in case of the HPT) or the inter-duct (for the LPT inlet geometry).

The **annulus of turbines** is mainly affected by the ratio of inner exit radius / inner inlet radius R_{exit} / R_{inlet} , the Inner Annulus Slope at inlet and exit of the turbine and the first and last blade aspect ratios. Study the effects of these quantities both with the HP and LP turbines employing the slider.

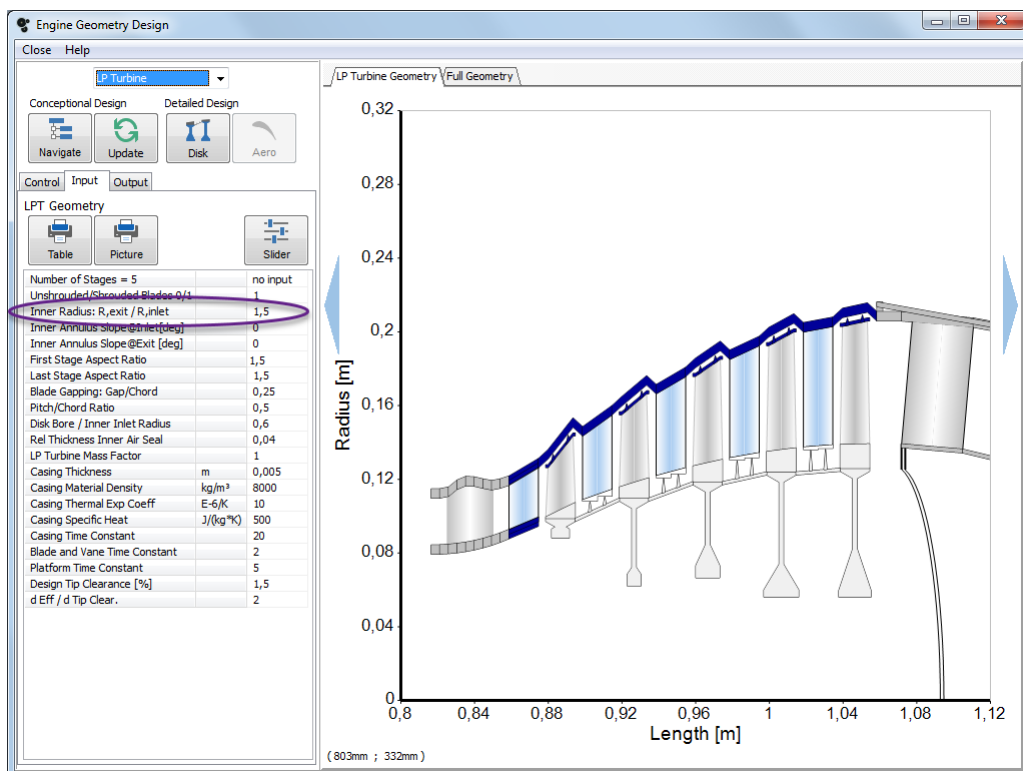



3.3.3 Other Components

Engine inlet radii are equal to those at the inlet to the downstream compressor. Therefore any modification of the input data for the inlet geometry affect only the length of the engine but not its diameter.

The radii at the inlet and the exit stations of a compressor *inter-duct* are determined by the up-respectively downstream compressors. The duct length is calculated from the *Length/Inlet Radius Ratio*, the outer annulus contour of any duct is derived assuming a linear flow area transition from the inlet to the exit station.

The burner inlet radius is equal to the radius found for the HP compressor exit. With the *Exit/Inlet Radius Ratio* and the *Length/Inlet Radius Ratio* you can modify the shape of the burner and the inlet radius of the HP turbine. Note that you need quite different numbers for describing the burner geometry if you switch from an axial design to a reverse flow combustor.

In case of turbine inter-ducts the hub radius at the exit is calculated from the given ratio *Exit/Inlet Radius*. The shape of the inner contour can be influenced with the slope values at the duct inlet and exit.

The turbine exhaust duct and the *nozzle geometry* are connected in such a way, that the inner cone can extend into the nozzle respectively into the exhaust diffuser. How far the cone protrudes into the downstream component depends on the nozzle design option (standard convergent or convergent-divergent nozzle, plug nozzle or power generation exhaust) you have selected.

3.4 Disk Design

When you are done with a first preliminary flow annulus then have a look at the disk dimensions and the disk stress design margins. To this end, click *Disk Design* when one of the components in possession of disks is selected. This will open the *Disk Design* window.

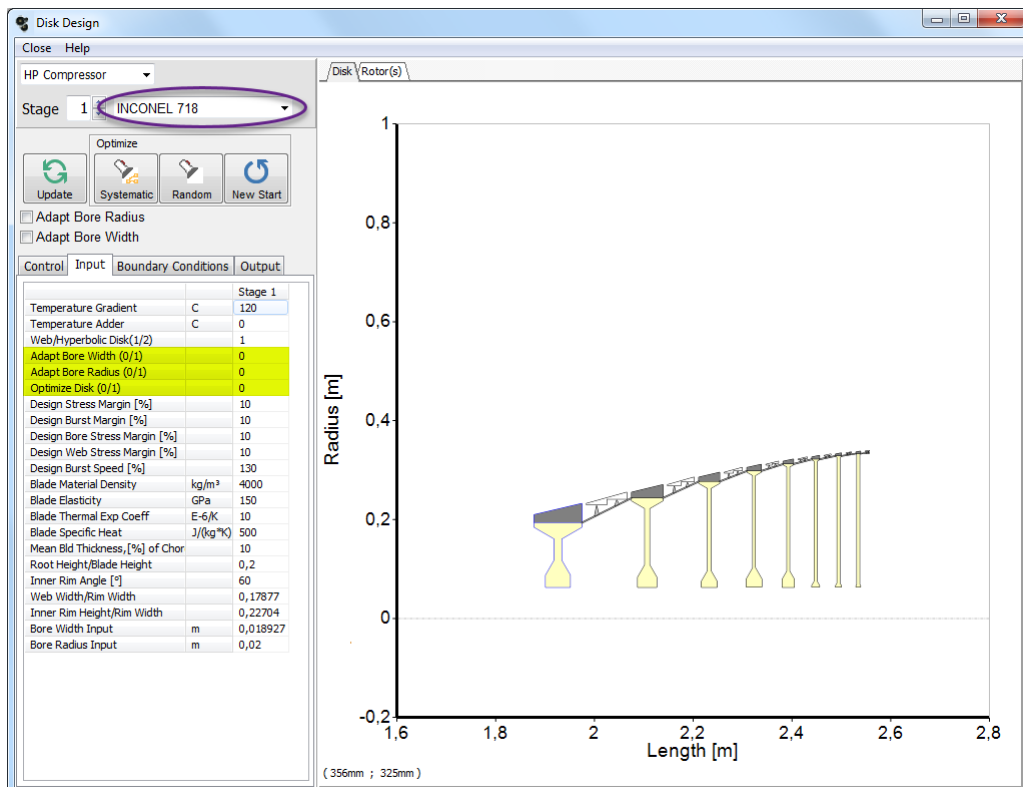

The *Input* tab sheet on the left contains all the input data for the selected stage, which can directly be edited in this table. Other stages and even components can be selected by means of the *Component Selection* box and the *Stage* spin box on the left.

The data in the *Boundary Conditions* tab sheet are also input data for the stress calculations, however, they can only indirectly be addressed because they are a result of the cycle and annulus design calculations.

Note that one - for the disk design very important - quantity is not found on the *Disks* window but in the *Engine Geometry Design*: this is the ratio of *Disk Bore / Inner Inlet Radius* which yields the lower limit of the bore radius for all disks.

The highlighted three lines in the table control the disk design algorithm, the options are explained in detail in the [Disk Design Methodology](#) section. You can edit the values for *Adapt Bore Width*, *Adapt Bore Radius* and *Optimize Disk* in the table. However, it is easier to use the options available in the *Disks* button group above the table.

It is recommended to optimize one disk after the other. Go to the *Control* tab sheet, check *Show Disk Mass* and to get a view of the compressor respective turbine. Perform several optimization runs for each disks. Begin the optimization from various start points and employ both the *Random Search* and the *Systematic Search*. It will not take much time until you get a satisfactory result.

Before you go to the *Drawing* or another page you should uncheck *Optimize*. Otherwise the response of your computer to any action will be very slow because the disk optimization remains active.

If you are unable to get sufficient disk stress margins then use better materials, reduce rotational speed or make any other suitable change to either the component geometry or to the cycle. Check also if an unnecessarily high value for the *Disk Bore / Inner Inlet Radius* (in the *Engine Geometry Design* window) prevents a successful disk design. Remember, however, if you choose a too low disk bore radius then you will get problems with the LP spool diameter.

Off-Design Performance



IV



4 Off-Design Performance

4.1 General

Off-design studies deal with the behavior of a gas turbine with given geometry. This geometry is found by running a single [cycle design point](#). The cycle design calculation is done in the background automatically if you - after starting the program - directly go for off-design simulations.

Note that you can select reheat during off-design only when you have set up your cycle design point with an afterburner. Similar restrictions apply for the use of recuperators, propellers and nozzle types.

To prepare for an off-design simulation, at first the component design points must be correlated with the component maps. This can be done automatically using [Standard Maps](#) and standard design point settings in these maps. The maps will be scaled before the off-design calculation commences in such a way, that they are consistent with the cycle design point. This approach works well if you are interested mainly in the basic off-design behavior of an engine type.

However, if you want to do a more accurate simulation for a specific engine then you should use not the Standard maps. Directly after the *Off-Design Input* window opens, before modifying any of the data, click the *Special* button in the *Maps and Connections* button group. Load maps that are suited for your engine and decide for a map scaling option. After closing the *Special Component Maps* window save your data as an [Engine Model File](#).

4.1.1 Data Files

4.1.1.1 Standard Data Files

A *Standard Data File* contains all input data, the definition of the composed values, the iterations defined for the design point and for off-design and so on. If you want you can look at a data file generated with GasTurb 13 with your favorite ASCII editor to see exactly what is stored.

Click  (*History*) to open an editor which allows you adding comments to your data. Make use of this option to document the background of your input data and the changes that you have made later.

Standard Data Files do not contain any information about the component maps to be used for off-design simulations.

4.1.1.2 Engine Model Files

For more accurate off-design simulations you will use a modified scaling of the standard maps or special maps. Selecting the appropriate component maps and correlating the cycle design point with these maps needs some effort. You can store the map scaling information in a special [Map Scaling File](#) or you can combine it with a [Standard Data File](#) which results in an **Engine Model File**.

You can create *Engine Model Files* from the *Off-Design Input* window while all input data are identical to those from the cycle design point. It is strongly recommended to store all referenced component map files in the directory where *Engine Model File* is stored.

After reading an *Engine Model File* the cycle design point is calculated in the background and all maps are read and properly scaled.

4.1.1.3 Map Scaling File

After clicking the  (*Special*) button in the *Maps and Connections* button group you must decide for each compressor and each turbine before the off-design simulations:

- which map should be read from file
- how to correlate the cycle reference point with the map
- what Reynolds corrections shall be applied

You can save your settings in a *Map Scaling File* in which the following information will be stored:

- the paths to the component maps
- the coordinates of the cycle reference point in the map β_{ds} and N/\sqrt{T}_{ds}
- the Reynolds correction data
- the [map reference speeds](#)

Note that the map scaling information is also stored in an [Engine Model File](#).

4.1.2 Compressor Maps

4.1.2.1 Map Scaling Procedure

After having calculated a single cycle in design mode, you can go on to do off-design calculations. Before you actually can do that the cycle design point must be correlated with the compressor and the turbine maps. The component maps need to be scaled in such a way that the design point is in line with a specific point in the map, the *Map Scaling Point*. If you select the [Standard Maps](#) in the program opening window this is done automatically.

If you have got compressor maps that are better suited for your machine than the *Standard Maps* then you should use them as [Special Maps](#). For good simulations you should always use the best maps available. Scaling a single-stage fan map to a pressure ratio of 10 would certainly not be a reasonable approach.

4.1.2.2 Standard Maps

For each of the compressors and turbines there is one standard map delivered together with the program. All these maps are taken from open literature and they are all from axial through flow turbo machines except the last compressor for the two configurations with axial-radial high pressure compressors.

All the maps are physically sound representations of real turbo machines. They may be scaled within certain limits to represent the behavior of similar engine designs. However, if the compressor design pressure ratio deviates significantly from that of the original map then particularly the speed-flow relationship will be represented incorrectly. For accurate simulations high quality maps especially for the compressors are needed.

All maps will be scaled before the off-design calculation commences in such a way, that they are consistent with the cycle design point. For checking the map scaling point click the *Special* button in the *Maps and Connections* button group.

4.1.2.3 Selected Maps

The validity of off-design calculations depends on how accurately the component maps reflect the behavior of the analyzed machine. All standard maps contain assumptions regarding the design of their components, which may be more or less appropriate for the designed gas turbine. The standard



map for compressors is one for an axial machine and therefore probably not the best choice for radial compressors. In case of the booster the standard map is best suited for transonic compressors. It is therefore a good choice to represent the highly loaded booster of a geared turbofan, but less suitable for the subsonic booster of a conventional turbofan.

The catalog of preselected maps offers multiple different maps for all components, each of them representing a common compressor or turbine design. This allows for choosing the most suitable component maps with regard to the calculated cycle and machines. All maps with their respective data sources are listed in the table below. [Selectable turbine maps](#) are available as well.

Overview of selectable Compressor Maps

	Name	File Name	Data Source
Fan	Single Stage Fan	SingleStgFan.MAP	Cumpsty, N.: Jet Propulsion. A Simple Guide to the Aerodynamic and Thermodynamic Design and Performance of Jet Engines. Cambridge University Press, 1997
	Multi Stage Fan	LowBPRFan.MAP	Koff, B.L.: F100-PW-229 Higher Thrust in Same Frame Size. ASME 88-GT-312, 1988
IPC	Subsonic Compressor	SubsonicCompressor.MAP	CFM56-3 test at TAP Portugal
	Transonic Compressor	TransonicCompressor.MAP	Converse, G.L.: Extended Parametric Representation of Compressor Fans and Turbines, Vol III. NASA CR-174647, 1984
HPC	Low Pressure Ratio	LowPqPCompr.MAP	Cumpsty, N.: Jet Propulsion. A Simple Guide to the Aerodynamic and Thermodynamic Design and Performance of Jet Engines. Cambridge University Press, 1997
	Medium Pressure Ratio	MediumPqPCompr.MAP	Halliwell, I.: Preliminary Engine Design - A Practical Overview for the NASA John H. Glenn Research Center, 2000
	High Pressure Ratio	HighPqPCompr.MAP	Cline, S.J. et al.: Energy Efficient Engine High Pressure Compressor - Component Performance Report. NASA CR-168245, 1983
Rad	Single Stage Radial	SingleStgRadialCompr.MAP	Numeca International: Radial Compressor Test Case. Announcement in the Press, 1999
	Twin Stage Radial	TwoStgRadialCompr.MAP	Palmer, D.L. and Waterman, W.F.: Design and Development of an Advanced Two-Stage Centrifugal Compressor. ASME 94-GT-202, 1994

4.1.2.4 Special Maps

If you have better maps than the Standard Maps of GasTurb 13 for the engine to be simulated then you can use them. Click the  (*Special*) button in the *Maps and Connections* button group for that purpose. The *Special Component Maps* window will open and show the presently loaded component maps. If you open this window for the first time (and you are not using an [Engine Model File](#)) then you will see the standard component maps.

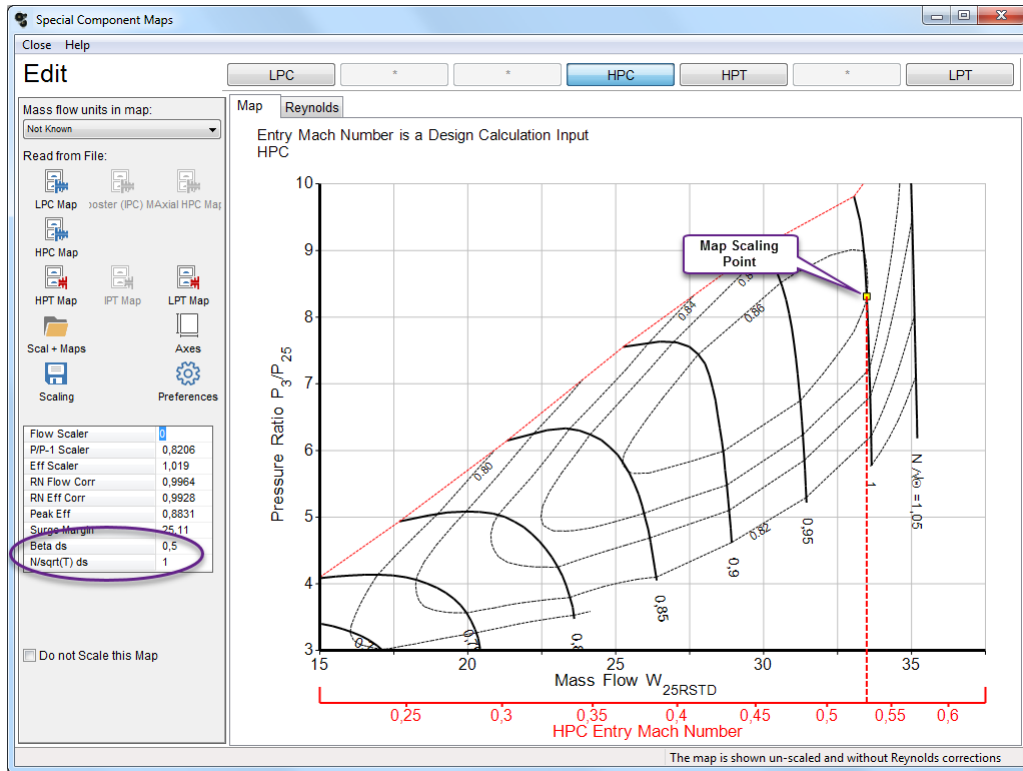

In the figure above you see the unscaled **Standard Map** employed for most high pressure compressors with the standard cycle design point setting which is on the speed line marked $N/\sqrt{\Theta}=1$ and at the **auxiliary coordinate** $\beta=0.5$. This **Map Scaling Point** - which is connected to the cycle design point - is marked as a yellow square and the coordinates of this points are shown in the table on the left.

Note that there are two x-axes, one for corrected flow and a second with compressor entry Mach number. In a pure thermodynamic cycle study – in which engine size does not matter - it is not necessary to consider the Mach numbers in the flow annulus. The map scaling point can be positioned in such a way that the desired performance characteristic within the operational envelope is achieved.

Higher fidelity simulations will go beyond thermodynamics and consider the size of the engine. The main dimensions of the flow annulus are either calculated or even known in advance - when an existing engine is to be modeled, for example.

During the cycle design calculations the axial Mach number can be unambiguously calculated from the flow annulus area and the corrected flow. In a proper performance model the x-axis coordinate of the map scaling point must be consistent with this Mach number.

If the preselected map scaling point is not in the right place because it results in less surge margin than needed for your application, for example, then you can reset it. Click on the yellow square and drag it to a better place. Instead of using the mouse you can also specify the position of the design point in the map by editing its coordinates $N/\sqrt{T}, ds$ and $Beta, ds$ in the table. This option is of advantage if you want to repeat exactly what you have done before.

Note, however, the consequence of moving the design point around in the map: The values for all efficiency contours – and especially the **peak efficiency** of the scaled map - will change. If you move the design point to a map region with low efficiency, then the peak efficiency of the scaled map will increase because the efficiency of the cycle reference point remains constant. Check the consistency of the scaled map with your cycle design point data. Normally, you cannot have a very high compressor surge margin and good efficiency at the same time.



If you have the true map of the compressor and the corrected mass flow is given in the map in the units which GasTurb 13 uses then you can apply the procedure that is explained in detail with an example for the TURBOJET engine. For the use of un-scaled component maps with GasTurb 13, there is a further, more direct, option available.

4.1.2.5 Efficiency Scaling

The following three efficiency terms play a role in efficiency scaling:

- The cycle design point efficiency $E_{23_{ds}}$.
- From the pressures and temperatures at the cycle design point the Reynolds Number Index RNI can be calculated and that yields the Reynolds number correction for efficiency. When the Reynolds correction is removed from the cycle design point efficiency one gets $E_{23_{ds,RC}}$ which is equal to $E_{23_{ds}}$ (if no Reynolds correction is applied) or higher than $E_{23_{ds}}$.
- In the unscaled map the efficiency at the map scaling point is $E_{23_{ds,M}}$.

The map scaling is done by multiplying all numbers in the efficiency table of the unscaled map with the factor $f_{E23} = E_{23_{ds,RC}} / E_{23_{ds,M}}$. This yields at the map scaling point during off-design simulations exactly the cycle design point efficiency if the Reynolds number index is the same as in the cycle design point.

The peak efficiency in a map is the highest efficiency value within the scaled component map. This efficiency will be read from the map when the operating line passes through the point with the peak efficiency and the Reynolds Number Index RNI is so high that no Reynolds correction is applicable.

Note that the map scaling point (representing the cycle design point) is normally not at the location of the peak efficiency.

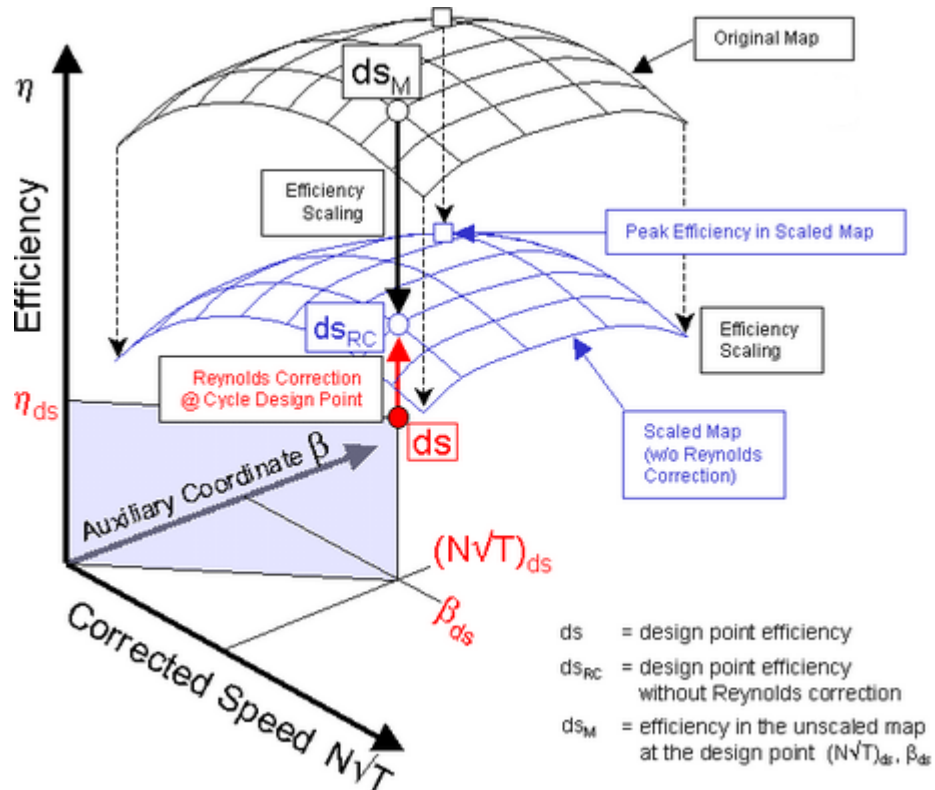

4.1.2.6 Map Scaling Example

Let us take the compressor map of a turbojet with the following cycle design point data:

Corrected Mass Flow	$(W\sqrt{\Theta/\delta})_{dp}$	90.0
Pressure Ratio	$(P_3/P_2)_{dp}$	9.0
Efficiency	h_{dp}	0.85

The **corrected spool speed** of the design point is taken as a reference in all off-design calculations. It holds by definition:

Corrected Speed	$(N\sqrt{\Theta R})_{dp}$	1.000
-----------------	---------------------------	-------

For off-design calculations, the design point must be correlated with the map. This means that one point in the map - the *map scaling point* - serves as a reference point (subscript R,map) with which the design point (subscript dp) is matched. As a default, the map scaling point is at $\beta_{R,map}=0.5$ and $N\sqrt{\Theta_{R,map}}=1.0$. Using $\beta_{R,map}=0.5$ and $N\sqrt{\Theta_{R,map}}=1.0$ along with the standard map **HPC01.MAP** yields

Corrected Mass Flow	$(W\sqrt{\Theta/\delta})_{R,map}$	33.48423
Pressure Ratio	$(P_3/P_2)_{R,map}$	8.311415
Efficiency	$h_{R,map}$	0.860100

Note that for reading these values from the map tables a linear interpolation between $\beta=0.47368$ and $\beta=0.52632$ is required.

The value read from the map tables needs to be corrected for Reynolds number effects with the terms $f_{\eta,RNI}$ and $f_{W,RNI}$ to be comparable with the design point efficiency η_{dp} :

$$\eta_{dp,map} = \eta_{R,Map} \cdot f_{\eta,RNI}$$

$$\left(W\sqrt{\Theta_R / \delta} \right)_{dp,map} = \left(W\sqrt{\Theta_R / \delta} \right)_{R,map} \cdot f_{W,RNI}$$

Now, the map scaling factors can be calculated (assuming $f_{\eta,RNI} = 0.99$ and $f_{W,RNI} = 0.995$):

$$f_{Mass} = \frac{\left(W\sqrt{\Theta_R / \delta} \right)_{dp}}{\left(W\sqrt{\Theta_R / \delta} \right)_{R,map} \cdot f_{W,RNI}} = 2.70134$$

$$f_{Eff} = \frac{\eta_{dp}}{\eta_{R,map} \cdot f_{\eta,RNI}} = 0.99824$$

$$f_{P_3/P_2} = \frac{\left(P_3 / P_2 \right)_{dp} - 1}{\left(P_3 / P_2 \right)_{R,map} - 1} = 1.09418$$

$$f_{Speed} = \frac{1}{N_{R,map}} = 1.0$$

These map scaling factors are applied to all the numbers in the efficiency table of the map. After applying the scaling procedure the map will be in line with the cycle design point.



4.1.2.7 Another Map Scaling Example

Select the TURBOJET configuration, load the file **Demo_jet.CYC** and modify the input for the cycle design point as follows:

Inlet Corrected Flow W2Rstd	32 kg/s
Pressure Ratio	8.0
HPC Efficiency (isentropic)	0.86575

Let us now assume for this example, that the map on the screen is correctly describing the compressor, we want to use the map unscaled. This requires that the map coordinates of the design point are adjusted in such a way that both scaling factors (for mass flow and pressure ratio) are equal to 1:

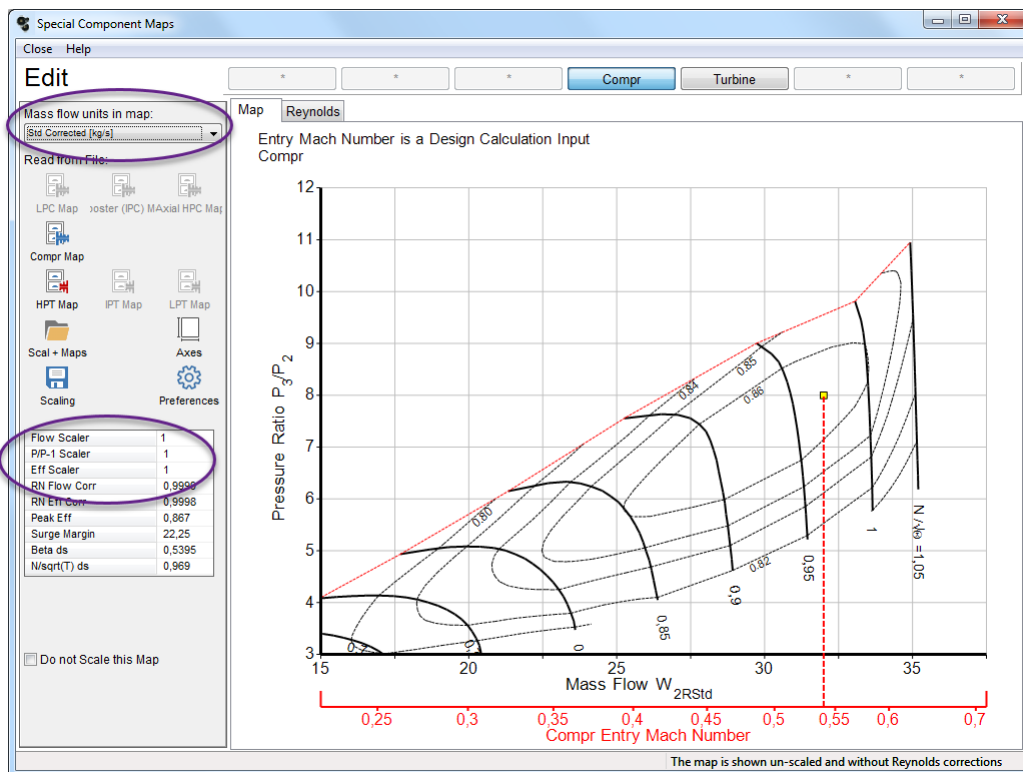

Move the yellow square with your mouse or edit the numbers for *Beta,ds* and *N/sqrt(T),ds* in the table. Make sure that you have selected the correct units for the mass flow numbers from the drop down selection list in the top left corner of the window.

If you want to use a map unscaled there is one problem with this approach: If you set the scaling factors for mass flow and pressure ratio to 1.0, you can end up with an efficiency scaling factor that is not equal to 1. In this case you must go back to the cycle design point and modify your efficiency number in such a way that you get also for the efficiency scaling factor a value of 1. Have a look at the other option to [use unscaled maps](#) which does not have this problem.

4.1.2.8 Use of Unscaled Compressor Maps

In an alternative way to use unscaled maps with GasTurb 13 the *Beta* value of the operating point will be found from *Pressure Ratio* and *Mass Flow* during the iteration for an off-design operating point. To make that feasible the units for the mass flow must be known: In GasTurb 13 they must be given as standard corrected values in kg/s even if the simulation is done with other units.

For locating the *speed line* in the map two quantities must be known, the *Map Reference Speed* N_{MR} and the *Map Reference Corrected Speed* $(N/\sqrt{\Theta})_{MR}$. This is because GasTurb employs relative speeds in component maps, not absolute speeds.

While scaled maps are used, during the map scaling process the speed values are scaled in such a way that the cycle design point CDP gets the corrected speed value of 1:

$$N_{corr,rel} = \frac{N / \sqrt{\Theta}}{N_{CDP} / \sqrt{\Theta_{CDP}}} = \frac{Z X N \cdot N_{CDP} / \sqrt{\Theta}}{N_{CDP} / \sqrt{\Theta_{CDP}}} = 1.0$$

Also the *relative spool speed* is per definition equal to 1.0:

$$Z X N = N_{rel} = N / N_{CDP} = 1.0$$

A map which is to be used unscaled employs relative corrected speed values as any map in GasTurb and the relative corrected speed in the map is defined as

$$N_{corr,map,rel} = \frac{Z X N \cdot N_{MR} / \sqrt{\Theta}}{(N / \sqrt{\Theta})_{MR}} = 1.0$$

Thus both N_{MR} and $(N/\sqrt{\Theta})_{MR}$ must be known for locating the speed line in an unscaled map.

N_{MR} and $(N/\sqrt{\Theta})_{MR}$ can be stored with the map on a separate line after the Reynolds correction data. The keywords "MAP REFERENCE SPEED =" and "MAP REFERENCE CORR SPEED =" must be used and both values must be given in rpm. You can also enter the *Map Reference Speed* and the *Map Reference Corrected Speed* in the *Special Component Maps* window. As soon as you check the *Do not Scale the Map* checkbox the following data input grid shows up:

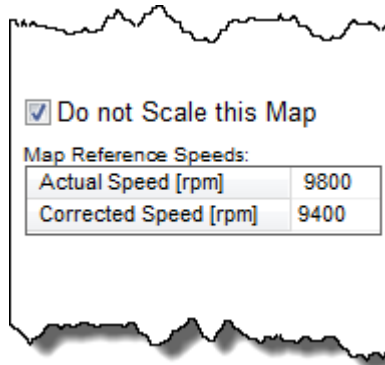

<input checked="" type="checkbox"/> Do not Scale this Map	
Map Reference Speeds:	
Actual Speed [rpm]	9800
Corrected Speed [rpm]	9400

To avoid confusion it is required, that the map reference speed N_{MR} for all components on the same spool is the same. If a gearbox connects the components, then the gear ratio will be taken into account in this requirement. An *Engine Model* can use a mix of scaled and unscaled maps.

4.1.2.9 Single Stage Fan Map Scaling

In the maps from single stage transonic fans the speed lines in the in the high speed / low pressure ratio region of the map are vertical. This means that the velocity triangles at the rotor inlet are invariant - the flow field upstream of the throat remains unaffected when the pressure ratio is reduced.

If the relative rotor inlet flow conditions in a single stage fan without inlet guide vane are supersonic, then the corrected flow is directly proportional to corrected speed. This knowledge can be used for setting the map scaling point correctly.



Setting the map scaling point for such a fan is a special case. The Mach number of the map scaling point is the fan face Mach number. Selecting a map scaling point connects a corrected flow value from the map with this Mach number.

The figure below shows what we get as Mach number axis if we set the map scaling point (which has in this example a Mach number of 0.7) on the line for the highest speed (N=1.1). For the vertical part of the speed line N=1 we read the Mach number of 0.66. In the map region where the speed lines are vertical (i.e. the rotor blade passages are choked) a 10% increase in speed goes along with an increase of the Mach number by 10%. For the Mach number increase from 0.66 to $0.66 \cdot 1.1 = 0.73$ we can evaluate a value for the corresponding corrected flow increase. Looking at the map we find that this value can only be achieved with a speed increase of $\Delta N=12\%$. Such a setting of the map scaling point is not in line with the laws of physics.

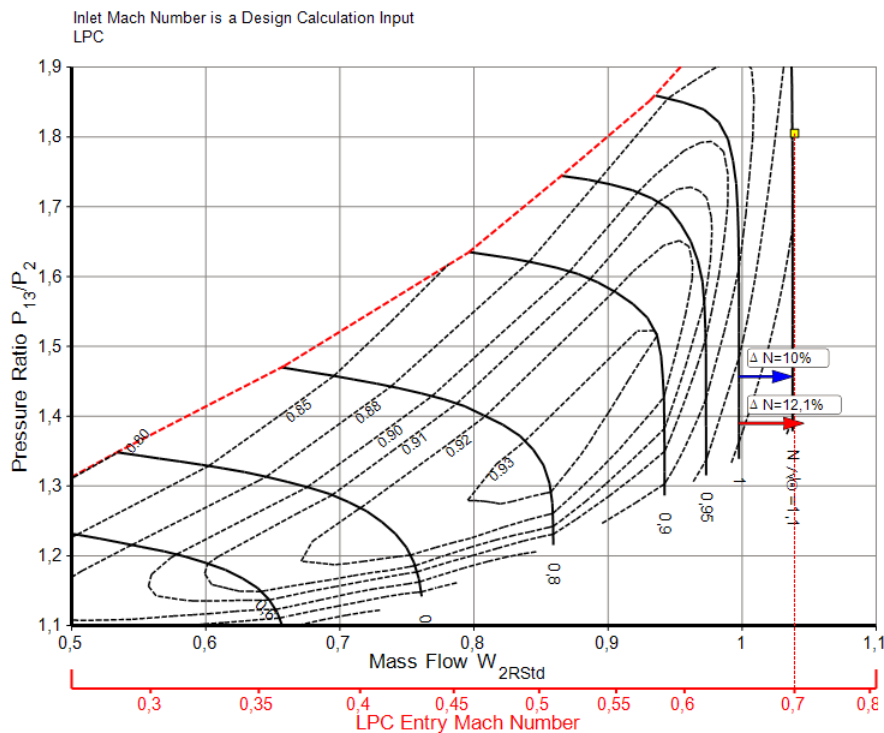

With the map scaling point setting chosen in the next figure the problem is gone. The corrected flow increase from speed 1 to 1.1 is consistent with a Mach number increase of 10% as it should be. This is the correct setting of the map scaling point.

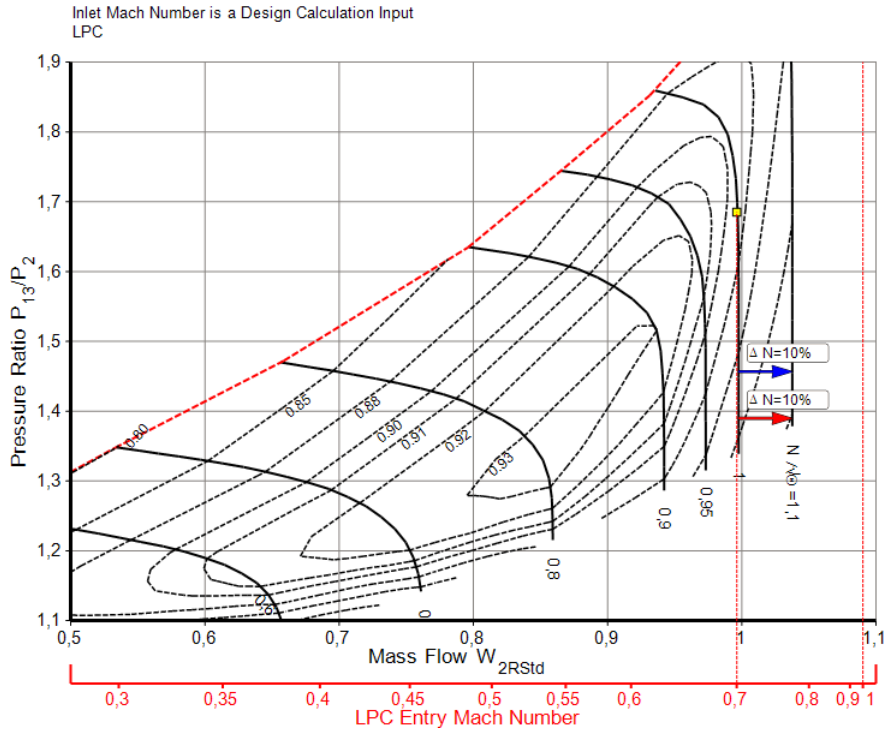

While in the first figure the map scaling point was set at too high corrected flow the opposite is true in the next figure. With the map scaling point on the speed line 0.9 the Mach numbers in the high speed region are impossible to get. The corrected flow for speed 1.1 would be higher than the theoretical maximum. Scaling the map with this position of the map scaling point would be a fault in the simulation.

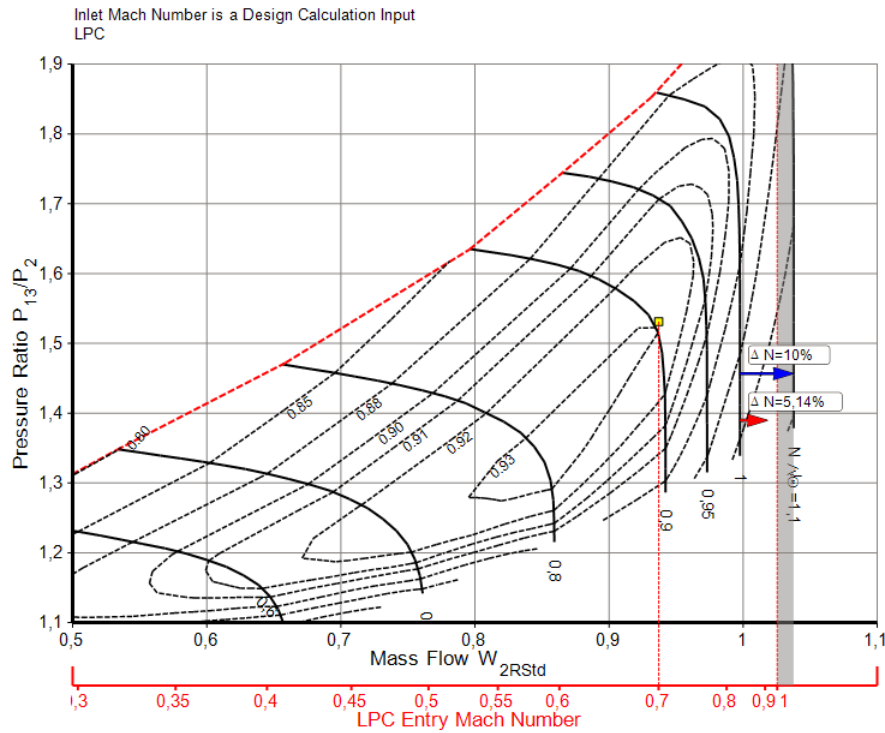



4.1.3 Turbine Maps

4.1.3.1 Turbine Map Scaling

Turbine map scaling is similar to compressor map scaling. Select in the *Special Components Map* window a turbine and you will get the following presentation of the map:

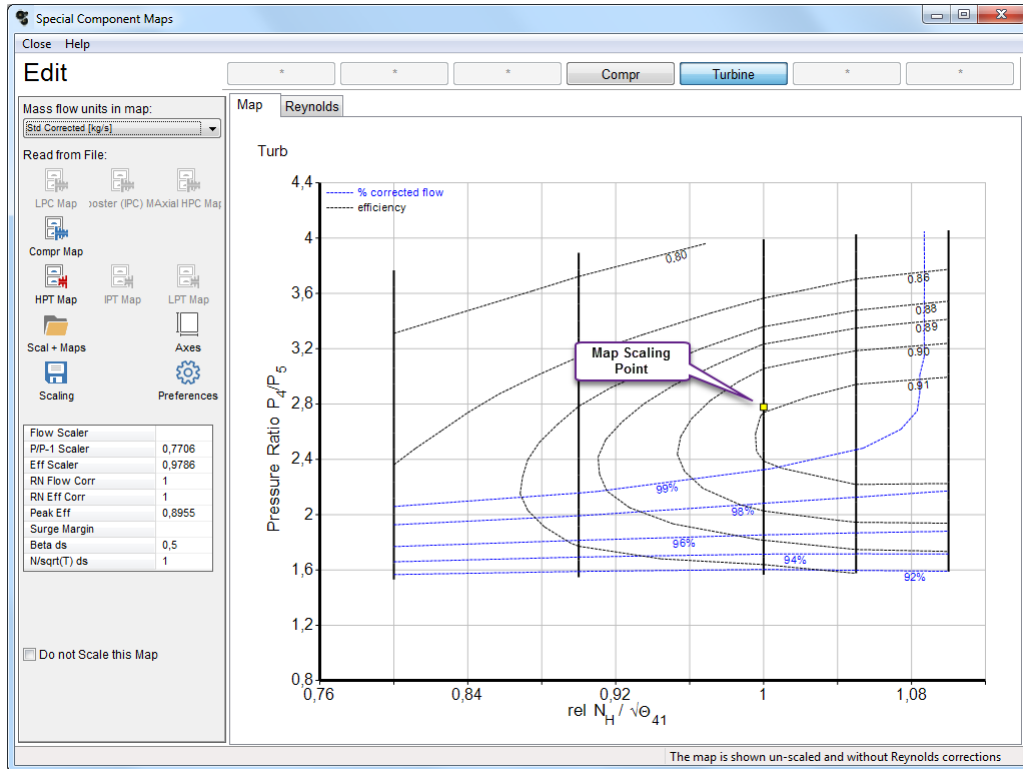

In this view on the turbine map there is no information about the absolute corrected flow and therefore no number for the flow scaler is shown in the table. Setting the map scaling point is possible with the mouse and also by entering numbers for the map speed value N/\sqrt{T} , ds and Beta, ds in the table.

Moving the *Map Scaling Point* around does not influence the performance at the cycle reference point, however, doing that influences how efficiency behaves at part load. If the map scaling point is positioned at the *peak efficiency point*, for example, then the part load efficiency will be worse than the design point efficiency at all other operating points (Reynolds corrections ignored).

The position of the map scaling point has not only an effect on efficiency but also on corrected flow at part load if the turbine pressure ratio decreases:

- If the map scaling point is at a high map pressure ratio then the corrected flow will remain constant or decrease only little.
- If the map scaling point is at a low map pressure ratio then the corrected flow will decrease with pressure ratio.

How big the decrease of the corrected flow is depends only to a minor extend on the map speed value.

4.1.3.2 Selected Maps

Similarly to the library of [selectable compressor maps](#), it is possible to choose between multiple different maps in order to achieve the best modeling of turbine off-design behavior. The options are listed in the table below together with the data sources.

Overview of selectable Turbine Maps

	Name	File Name	Data Source
HPT	Single Stage	SingleStgTurbine.MAP	Stabe, R.G. et al.: Performance of a High-Work Low Aspect Ratio Turbine Tested with a Realistic Inlet Radial Temperature Profile, NASA TM-83655, 1984
	Two Stage	TwoStgTurbine.MAP	Timko, L.P.: Energy Efficient Engine High Pressure Turbine - Component Test Report. NASA CR-168289, 1984
LPT	Medium Pressure Ratio	MediumPqPTurbine.MAP	Broichhausen, K.: Aerodynamic Design of Turbomachinery Components - CFD in Complex Systems. AGARD Lecture Series 195, 1994
	High Pressure Ratio	HighPqPTurbine.MAP	Wilfert, G. et al.: CLEAN – Validation of a GTF High Speed Turbine and Integration of Heat Exchanger Technology in an Environmental Friendly Engine Concept. ISABE-2005-1156, 2005
Rad	Radial Turbine	RadialTurbine.MAP	Pullen, K.R.: The Design and Evaluation of a High Pressure Ratio Radial Turbine. ASME 92-GT-93, 1992

4.2 Input Data for Steady State

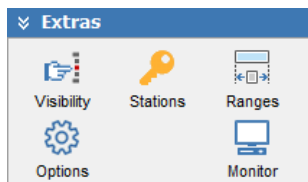

Most of the input quantities for steady state off-design simulations need no further explanations. However, there are exceptions and therefore some comments to special off-design input quantities are following in the next sections. Limiter settings and automatic handling bleed schedules are described in the section [Simulating the Control System](#).

During off-design calculations the cycle design point input quantities are normally not accessible. However, you can add some of them to the list of off-design input data after clicking *Input Visibility* in the *Extras* button group.

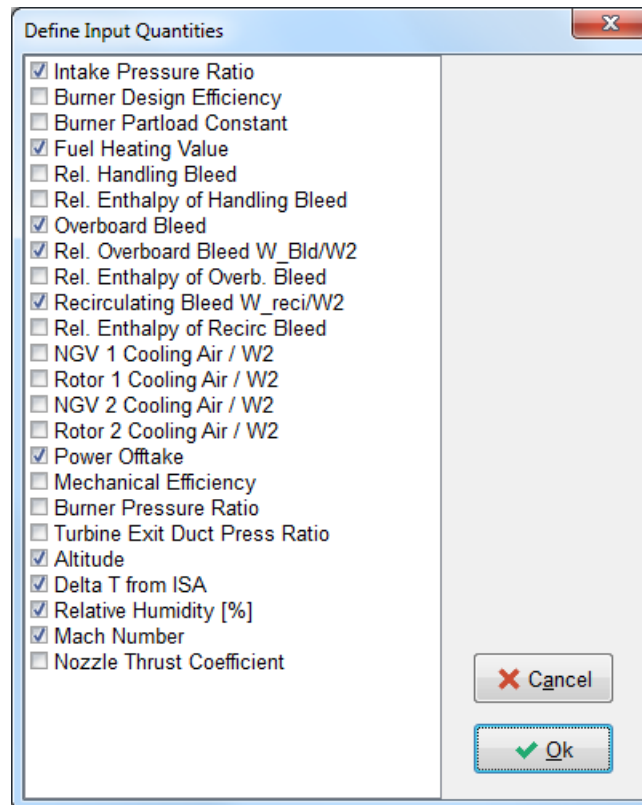

Take for example the *Burner Design Efficiency*. After having made it visible, you can modify it. Note, however, that the input value of *Burner Design Efficiency* is used together with the *Burner Partload Constant* for the efficiency calculation. Therefore the calculated burner efficiency will be equal to the *Burner Design Efficiency* only if the *Burner Partload Constant* is zero.

4.2.1 Z_{XN} or T₄ Given

You can select the engine operating condition either by specifying the relative high-pressure spool speed Z_{XN} or by setting the burner exit temperature T_4 .

- If you enter for *Z_{XN} given (1) or T₄ given (2)* the value 1 then Z_{XN} will be a prescribed value and the *Burner Temperature T₄* will be a variable in the standard off-design iteration scheme.
- If you enter for *Z_{XN} given (1) or T₄ given (2)* the value 2 then T_4 will be a prescribed value and the relative *HPC Spool Speed Z_{XN}* will be a variable in the standard off-design iteration scheme.

If one or more [limiters](#) are defined, then both Z_{XN} and T_4 are [iteration variables](#).

Single spool turboshafts driving a generator or a propeller operate at constant mechanical spool speed Z_{XN} . In this case the iteration variable for finding the maximum load is the load constant C in the formula

$$PW_{SD} = C \cdot PW_{SD,corr,ds} \cdot N^a$$

This formula is explained in more detail in the section dealing with the [operating line of a single spool turboshaft](#)

4.2.2 Con/Di Nozzle Area Schedule

To describe the geometry of a convergent-divergent nozzle with only one set of actuators during off-design simulations the area ratio A_9/A_8 can be made a quadratic function of A_8 :

$$\frac{A_9}{A_8} = a + b \cdot \left(\frac{A_8}{A_{8,ds}} \right) + c \cdot \left(\frac{A_8}{A_{8,ds}} \right)^2$$

Usually you enter the coefficients a, b and c already while calculating the cycle design point and therefore these quantities are not visible in the *Off-Design Input* window. However, you can make them visible by clicking *Input Visibility* in the *Extras* button group.

It must be noted, that the area ratio may be overridden by the [Maximum Effective Area Ratio](#), if the [Over-Expansion Limit](#) is switched on.

This is a typical shape of $A_9/A_8 = f(A_8)$ of a round convergent-divergent nozzle:

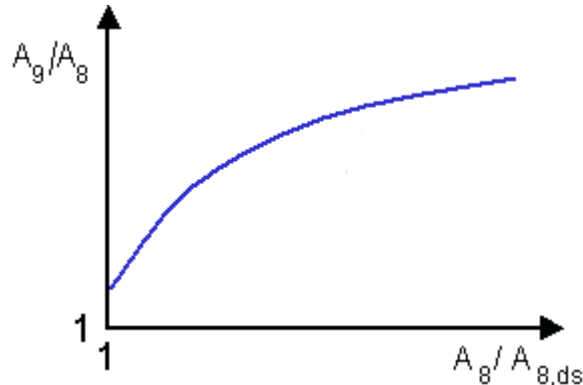

4.2.3 Iteration Variables

Each off-design simulation requires a multidimensional iteration in which several variables are unknown. Normally you need not bother about the values that estimated quantities have because they are only starting values for the off-design iteration. If the iteration does not converge, you can try to modify the estimated values to get better starting values for the iteration. This may lead to convergence if a solution exists.

Property	Unit	Value	Comment
Betavalue in HPC Map		0.497262	HPT Flow
Burner Temperature ZT4	K	1625.07	HPT Work
Betavalue in LPC Map		0.533986	Core Nozzle
LPC Spool Speed Z\NL		0.913009	LPT Flow
Estimated Bypass Ratio		8.54051	Byp Nozzle P/P
Betavalue in IPC Map		0.497805	IPC Flow
Betavalue in HPT Map		0.485473	HPC Flow
Betavalue in LPT Map		0.271518	LPT P/P
delta T Recirculating Bleed	K	-1.06557E-0!	T2-T1 Recirc

4.2.4 Inlet Flow Distortion

Inlet flow distortion simulations employ the [parallel compressor theory](#). A special calculation mode is initiated when you enter a number greater than zero for the [pressure distortion coefficient](#) or for the [temperature distortion coefficient](#).

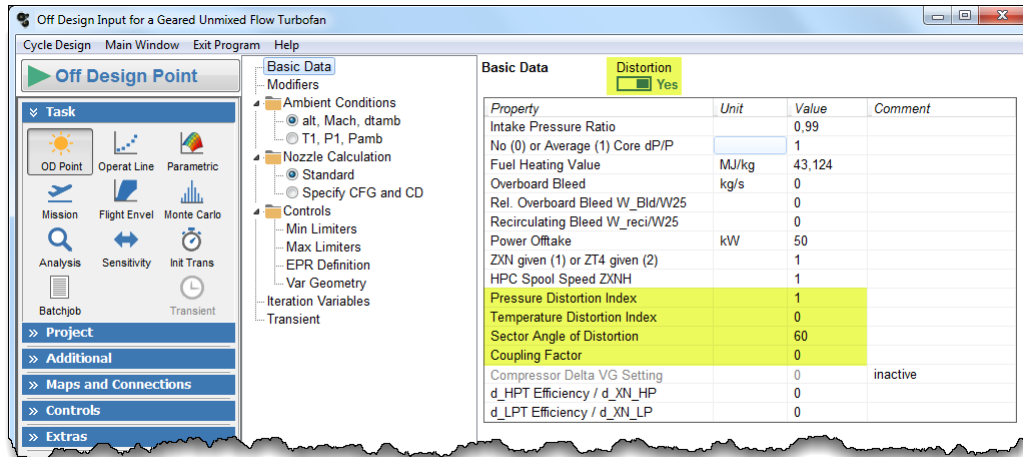

For a compressor with distorted inlet flow we get two operating points. To describe them both for each compressor an additional auxiliary coordinate β is needed. Furthermore, the bypass ratio in the spoiled sector of a two-stream engine is an extra iteration variable. The additional iteration errors are the differences in the static pressures downstream of the compressors.

Be careful with the values for the distortion coefficients. It is important to begin with low numbers, especially for the temperature distortion coefficient. Start your experiments with values around 0.5 for the pressure distortion coefficient and with 0.02 for the temperature distortion coefficient, for example. The iteration will not converge if the solution implies operating conditions in the spoiled sector well above the surge line or if the operating point of the distorted sector is in a map region in which, at constant speed, the pressure ratio increases with flow.

In the compressor maps you will see the operating points in the spoiled sector and also the mean operating point; the type of distortion will be indicated. Note that the compressors downstream of the first compressor will encounter temperature distortion even if just a pressure distortion is specified.

You can do simulations with inlet flow distortion only if you have calculated the flow area of the [aerodynamic interface plane](#) (AIP) during the cycle design calculation because the pressure distortion coefficient is defined on the basis of the dynamic head in the AIP.

4.2.5 Off-Design Turbine Tip Clearance Correction

In off-design simulations turbine efficiencies can be corrected for changes in tip clearance due to changes in mechanical spool speed.

The input property which controls this correction is the influence factor $d_HPT\ Efficiency / d_XN$. Setting this factor to 0.15 will create at 80% spool speed a delta HPT efficiency of $(1 - 0.8) * 0.15 = 0.03$, for example. If you set the influence factor to zero then no tip clearance correction will be applied.

4.2.6 Modifiers

Modifiers are properties that model changes of the engine geometry or the component performance. They can be used to model variable turbine and nozzle geometry, components of derivative engines, or engine deterioration, for example.

Efficiency modifiers are adders to the value read from the component map while other modifiers are factors applied to the relevant quantity. Thus an efficiency modifier of +1% will increase the efficiency

by 0.01 (i.e. by one point) while a turbine capacity modifier of the same magnitude is factors the turbine flow capacity by 1.01.

Compressor capacity changes are simultaneous changes of pressure ratio and mass flow along a line of **beta=constant**. Changing the compressor capacity by +1% will increase the mass flow by +1% and at the same time increase the pressure ratio according to the local gradient of the auxiliary map coordinate beta.

Turbine capacity changes are just a factor on the corrected flow read from the turbine map, no other turbine property is affected.

Modifiers for duct pressure losses are applied as factors to the cycle design point pressure ratio of the relevant duct. Remember that the actual pressure ratio of a duct depends not only on the design point pressure ratio but also on the corrected flow. Because the latter will change with the operating condition the respective duct pressure ratio will not change exactly by the value entered as pressure ratio Modifier.

Note: If you want to be fully consistent with the cycle design point, then all modifiers must be zero.

4.2.7 Variable Geometry (Compressor)

In the majority of cases you need not select the variable compressor geometry option in GasTurb for performance simulations as [explained](#) in the Getting Started section. One spool turboshafts running at constant speed for driving a propeller or a generator are an exception.

At the cycle design point the setting of the variable geometry is by definition 0°. Any deviation from this setting will affect mass flow, pressure ratio and efficiency. You have to decide on the magnitude of the following influence coefficients before simulating variable geometry for a compressor in an approximate way:

$$a_{VG} = \frac{\partial W [\%]}{\partial VG [^\circ]}$$

$$b_{VG} = \frac{\partial (P/P - 1) [\%]}{\partial VG [^\circ]}$$

$$c_{VG} = \frac{\partial \eta [\%]}{\partial VG [^\circ]}$$

The mass flow and the term (P/P - 1) will vary proportionally to the variable geometry setting VG[°], which is the input quantity *Compressor Delta VG Setting [°]*. GasTurb uses as a default for +1° change in variable guide vane setting a +1% change in mass flow and a +1% change in (P/P - 1) at constant spool speed.

Here is an example of a measured relationship between mass flow and the VG position which shows that the correlation is essentially linear:

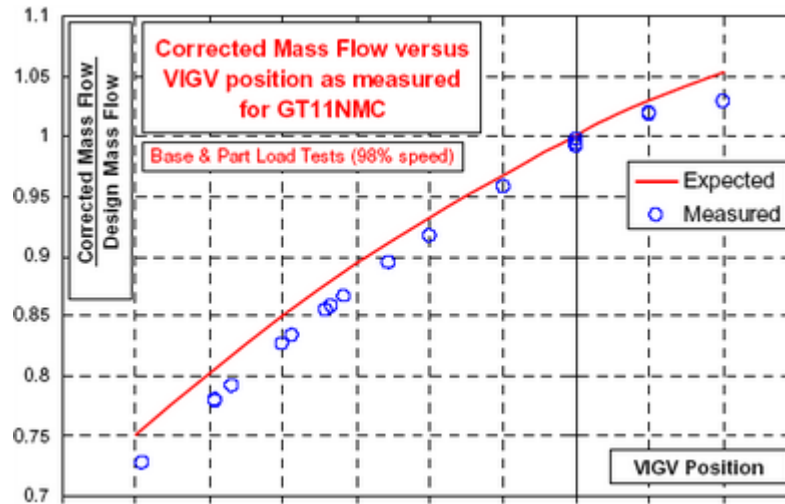

Ref.: S.M.Savic, M.A.Micheli: Redesign of a multistage axial compressor for a heavy duty industrial Gas turbine (GT11NMC), ASME GT2005-68315

The efficiency correction in GasTurb 13 is done using a quadratic function. The program will correct the efficiency according to the following formula:

$$\eta = \eta_{Map} \cdot \left(1 - \partial VG^2 \cdot \frac{C_{VG}}{100} \right)$$

This formula allows to describe perfectly the measurements reported in the paper referenced above as can be concluded from the following picture:

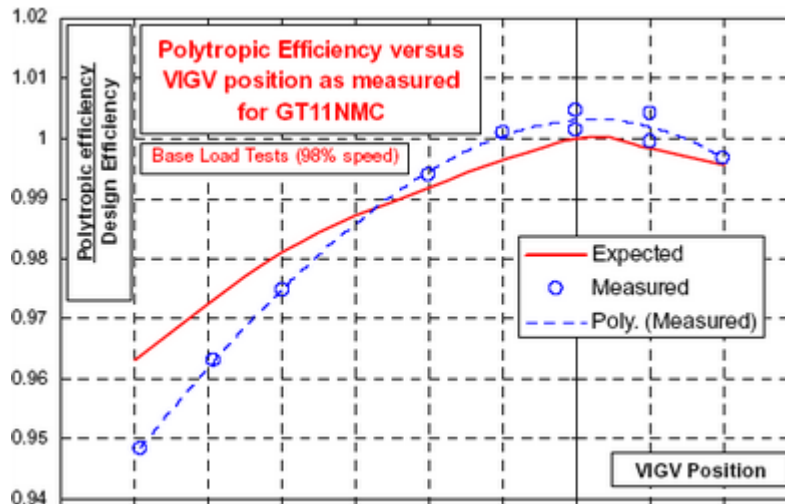

With the default influence coefficient of CVG= 0.01 you get for +/-10° off-nominal VG setting an efficiency decrement of 0.01 and +/- 15° deviation in VG setting yields an efficiency loss of 0.0225

4.3 Operating Line

4.3.1 General

An *Operating Line* (in some previous versions of GasTurb called a working line) is a series of points with equidistant values of high pressure spool speed, thrust or power, starting with the respective value of the last calculated single off-design point. Operating lines of a [single spool turboshaft](#) and [reheat operating](#) lines are special cases.

The input for running a [single operating line](#) has already been described in the *Getting Started* section. You can also calculate [many operating lines](#) in one go. The results for all operating lines will be shown together in the graphical output.

Note that you can also calculate several operating lines as an [off-design parametric study](#).

The results of an operating line calculation can be easily [compared](#) with those from other sources. Import your data and view them together with the GasTurb 13 results.

4.3.2 Single Spool Turboshaft

For a single spool turboshaft there are two basically different modes of operation. Engines used for power generation or as turboprops need to operate at [constant spool speed](#) while in other applications like ground vehicle or ship propulsion the [spool speed varies](#) with the shaft power delivered. Of course during startup the spool speed varies in any case.

4.3.2.1 Operation with Variable Spool Speed

If you calculate an [operating line](#) of a single spool gas turbine, then the shaft power delivered varies according to the following formula:

$$PW_{SD} = C \cdot PW_{SD,corr,ds} \cdot N^a$$

In this formula the quantity $PW_{SD,corr,design}$ is the corrected shaft power which was calculated during cycle design. It is corrected to ISA ambient conditions:

$$PW_{SD,corr,ds} = PW_{SD,ds} \sqrt{\frac{288.15 \text{ K}}{T_2} \frac{101.325 \text{ kPa}}{p_2}}$$

N is the relative spool speed, i.e. a number in the range 0.5...1.1 (N=1 represents the design point spool speed).

With normal ambient conditions the constant C is typically in the range from 0...1.2 and the exponent a the range from 3 to 5.

If you want to operate the gas turbine at constant turbine exit temperature for different values of relative spool speed Z_{XN}, then set on the *Max Limiter* page the T₅ limit and run a *Parametric Study* with *HPC Spool Speed Z_{XN}* as first parameter. Use the following input:

Start Value	1
Number of Values	11
Step Size	-0.05

Now the constant C will be adjusted automatically by the program in such a way, that the turbine exit temperature T₅ remains constant while the spool speed decreases.

4.3.2.2 Operation with Constant Spool Speed

For an application with constant spool speed you can vary the shaft power by modifying the constant C in the formula $PW_{SD}=C \cdot PSWD_{ds} \cdot N^a$. Select Z_{XN} given(1) on the *Basic Data* page and enter the



desired spool speed value as *HPC Spool Speed Z_{XN}*. Calculate one or more single points, do not use the [operating line](#) option for this special case.

When you want to run a series of points at constant spool speed automatically, then use a *Parametric Study*. Select the constant C as first parameter with the following values:

Start Value	1
Number of Values	5
Step Size	-0.2

You will get a power variation from full load down to zero load with constant relative spool speed *Z_{XN}*.

If you want to know the shaft power delivered with constant spool speed and constant turbine inlet temperature *T₄₁* while ambient temperature varies proceed as follows:

Set a *T₄₁* limiter and switch it on. Now the constant C will be adjusted automatically by the program in such a way, that *T₄₁* achieves the specified value while the spool speed remains constant in the *Off-Design Point* calculation mode. The shaft power delivered will vary with ambient conditions, for example.

If the engine has got variable compressor geometry then the shaft power delivered at constant spool speed and constant turbine temperature can be controlled with the variable guide vanes. Select on the *Var Geometry* page the compressor with variable guide vanes and select on the *Basic Data* page *Z_{XN}* given(1) i.e. operation with constant spool speed. On the *Limiter* page set the *T₅* limit to an appropriate value and switch the limiter on. Then run a *Parametric* with the first parameter *Compressor Delta VG Setting[°]* in the range 0 ... -50°, for example.

4.3.3 Reheat

The operating point in the turbomachinery component maps is the same for all points of a reheat operating line. Starting from the design point value of *T₇* the reheat exit temperature is decreased in steps of 100K. You can influence the position of the reheat operating point in the map by applying a modifier to the nozzle area *A₈*.

Note that you can calculate reheat for off-design conditions only if your design point was calculated with reheat switched on.

4.3.4 Off-Design Parametric Study

Instead of creating an [operating line](#) with several values for the high-pressure spool speed you can produce a series of points with different amounts of power offtake and customer bleed air extraction, for example. The parameter selection is the same as for [design point parametric studies](#). [Limiters](#) may be switched on and control schedules may be active during such an exercise. Also the [automatic handling bleed](#) will work.

The results of an off-design parametric study are also shown in the component maps. Note that the efficiency contours in the maps are valid for *RNI*=1 and efficiency *modifiers*=0 only. The efficiencies calculated in the cycle are often different because of Reynolds number corrections. So do not be surprised if you fail to find the same efficiency along the operating line in the HPC map and in the plot of HPC Efficiency over HPC Mass Flow.

It might happen that the off-design iteration does not converge during a parametric study. The reason for that is the sequence in which the operating points are calculated. Iterations begin with estimated values for the variables that are the result of the previously calculated operating point. These

estimated values will usually be near to the solution while a series of points is calculated. However, when the first series of points is finished and the next series commences, then the estimates might be quite far from the solution for that point.

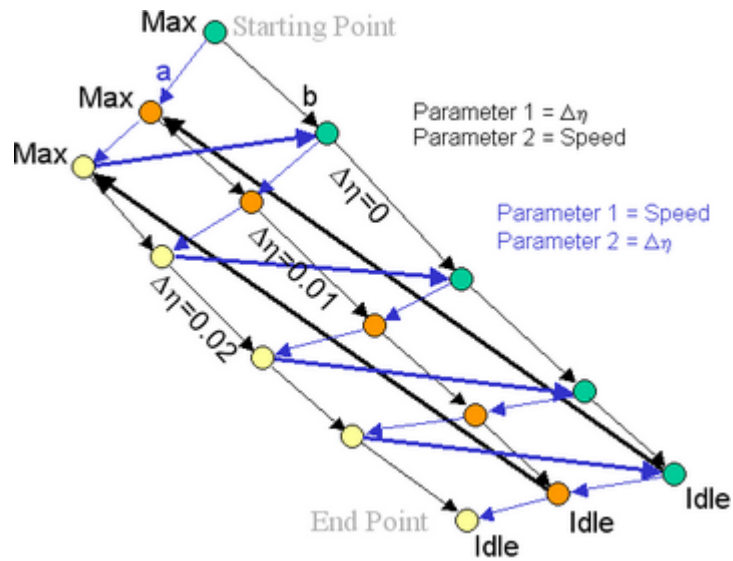

Calculation sequence in a parametric study

Consider as an example a parametric study in which parameter 1 is the relative gas generator spool speed being varied from 1.0 (Max Power) to 0.8 (Idle) in steps of -0.025 and the second parameter is a $\Delta\eta$ which varies from 0 to 0.02 in steps of 0.01. The first series of points is for $\Delta\eta=0$. The calculation will commence with the relative spool speed of 1.0 and will end with the relative spool speed of 0.8. The first point of the second series employs $\Delta\eta=0.01$ and begins again with relative spool speed equal to 1. This implies the big jump in compressor speed (from 0.8 to 1.0) and therefore the estimates for the iteration variables will be far from the solution for this operating condition. Consequently the iteration may fail to converge. The calculation sequence is indicated by the black arrows in the figure.

You can resolve the problem of this example easily by exchanging the parameters: Select the speed as parameter 1 and $\Delta\eta$ as parameter 2. With this alternate sequence of operating points - which is marked with blue arrows in the figure - the estimates for the iteration variables will always be near to the solution because the change from $\Delta\eta=0.02$ to $\Delta\eta=0$ has a much smaller impact on the operating point position in the component maps than the speed change from 0.8 to 1.0.

Exchanging the parameters is easy: just click the  (Swap) button in the *Parameter Selection* window.

4.4 Calculating a Series of Points (Mission)

Often one has to look in detail at many different off-design conditions of a gas turbine. This is made easy with the definition of a mission in which you can combine many operating conditions in a list. How to use the *Mission* option in general has already been described in the [Getting Started](#) section.

Missions serve several purposes within GasTurb 13:

- The results may be used during a cycle design point optimization for the evaluation of off-design constraints.
- They are offered for selection as contour lines in cycle design parametric studys.
- You will get the coordinates of the map scaling points of all components offered for selection with an off-design parametric study.



If you are interested in the average value which a quantity has during the mission, then define - before setting up the Mission - a composed value as *MissionAvg(...)*. Similarly you can sum up all values of a mission with the *MissionSum(...)* function. For calculating the fuel used within the complete mission, define the following two composed values:

```
SegmentFuel=InPar1*wf
MissionSum(SegmentFuel)
```

The duration of each segment of the mission (each point in the mission input list) is given with the input parameter *InPar1* in this example.

4.4.1 Mission List Output

		Point 1	Point 2	Point 3	Point 4	Point 5	Point 6	Point 7	Point 8
		Case 1	Case 2	Case 3	Case 4	Case 5	Case 6	Case 7	Case 8
Description									
Number of Iteration Loops		15.1	17.1	17.1	17.1	20.1	19.1	15.1	16.1
Altitude	m	0	0	0	0	0	0	2000	2000
Delta T from ISA	K	0	0	0	0	0	0	0	0
Relative Humidity [%]		0	0	0	0	0	0	0	0
Mach Number		0	0,244	0,479	0,715	0,953	1,2	0,25	0,486
Overboard Bleed	kg/s	0	0	0	0	0	0	0	0
Power Offtake	KW	0	0	0	0	0	0	0	0
Net Thrust	kN	115,251	112,347	113,739	121,875	134,591	151,225	93,1862	100,347
Gross Thrust	kN	115,251	121,806	133,738	155,528	186,55	227,584	100,912	116,844
Sp. Fuel Consumption	g/(kN*s)	56,6128	60,2716	63,8386	66,7746	69,6627	72,0954	58,1751	60,5686
Specific Thrust	m/s	1046,19	986,231	927,019	881,167	840,053	808,732	1002,81	983,077
Handling Bleed WB_hdi/W21		0	0	0	0	0	0	0	0
Total Rel Overb.Bld W_bld/W25		0,005	0,005	0,005	0,005	0,005	0,005	0,005	0,005
Burner Fuel Flow	kg/s	1,68065	1,75196	1,82966	1,96699	2,14513	2,32695	1,42679	1,58759
Reheat Fuel Flow	kg/s	4,84401	5,01936	5,43127	6,17114	7,23083	8,57565	3,99433	4,49026
Total Fuel Flow	kg/s	6,52466	6,77133	7,26094	8,13813	9,37596	10,9026	5,42112	6,07785
Overall Pressure Ratio P3/P2		20,0096	19,8983	18,5932	16,7669	14,5075	12,0031	20,8083	20,3335
HPT Pressure Ratio		2,88886	2,88848	2,88914	2,89053	2,89245	2,89079	2,8855	2,88695
LPT Pressure Ratio		2,18883	2,18999	2,20328	2,22507	2,256	2,2514	2,18382	2,18652
Isentropic LPT Efficiency		0,847778	0,848081	0,851797	0,858122	0,852383	0,843456	0,84289	0,845492

You may rearrange the sequence of the lines (drag-and-drop them) in the mission output table to put those items first that are of most interest for your specific problem. The rearranged list may be saved as a *Layout File* which will get the extension OUL.

Click the (*Details*) button to get the detailed output for the column in which the cursor is.

Clicking (*Graphics*) switches to the graphical output with all points. The program will find groups of data which belong together. All points of a data group can be marked and connected with lines.

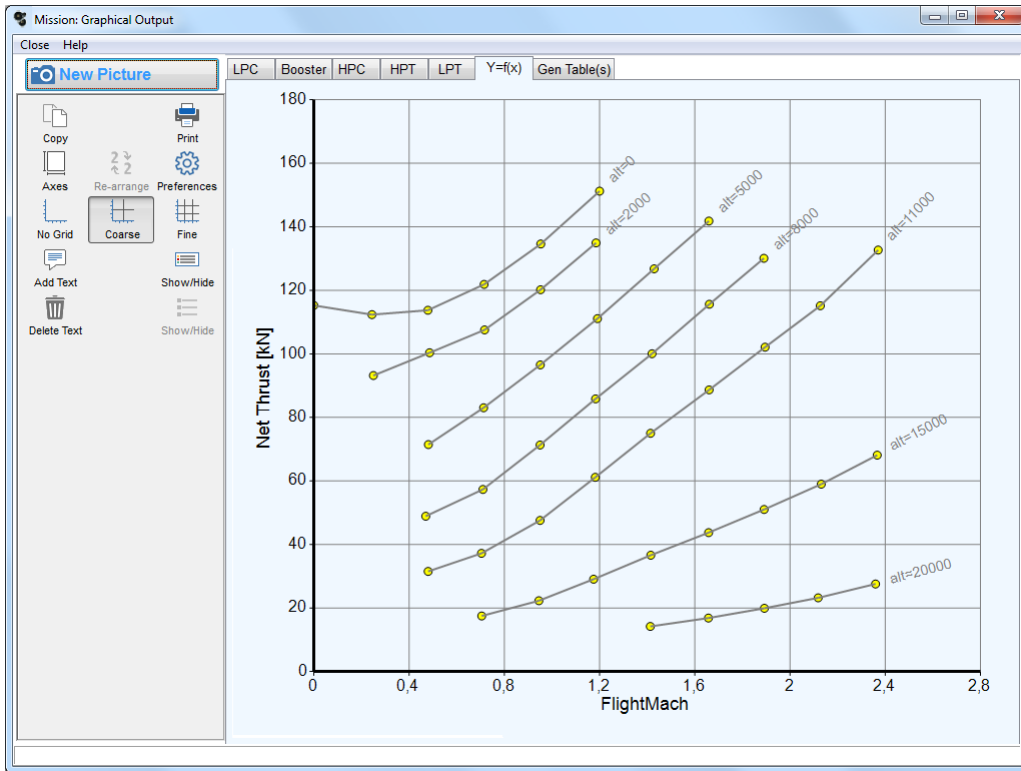

The data points can also be plotted as colored circles, where size and color represent two further quantities in addition to the plot axes. An example of these plots is shown in the figure below.

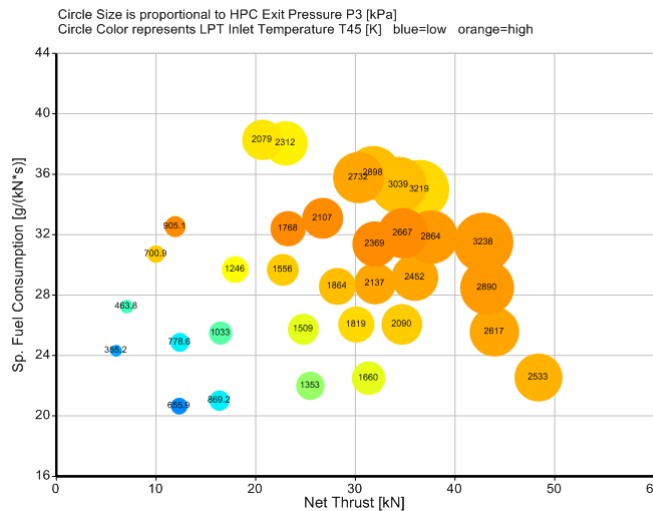

This plot is generated by entering the respective quantities in the boxes labeled *Symbol Size* is proportional to and *Symbol Color* represents magnitude of in the *Graphical Output Window*. To this end, select a parameter from the list on the left and drag it into the respective box.

4.4.2 Output Used as Input

Within a mission calculation it might happen, that the next operating condition of the engine depends on what the operating condition was before. GasTurb 13 allows transferring the result of a cycle calculation to an input quantity for the following mission point. Usually the input of interest will be a composed value calculated as part of the previous point.



Which output property is transferred to which input property must be defined before going to the *Mission Input* window. Click  (*Output=Input*) in the *Additional* button group to open the following window:

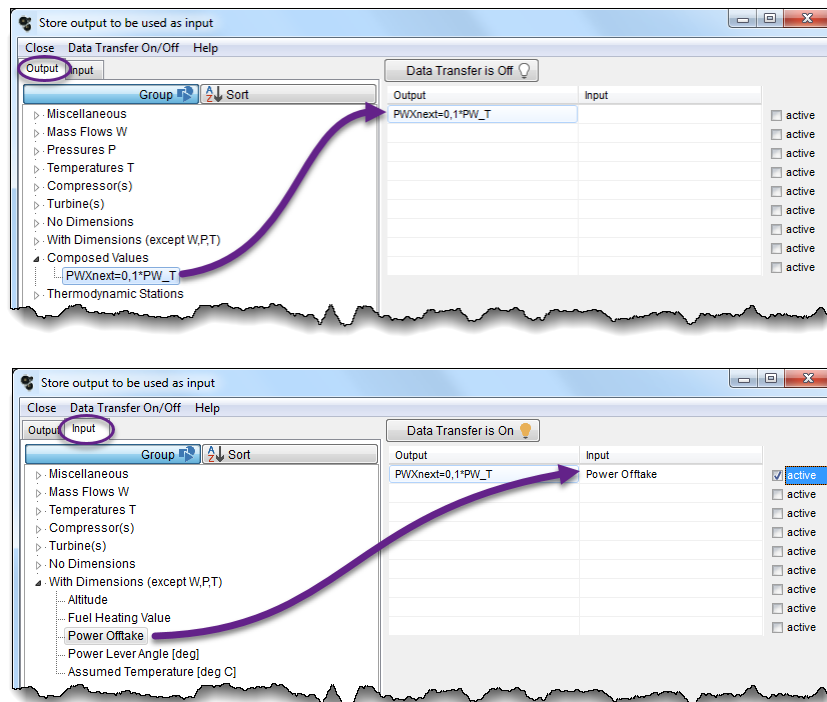

Modifying the data transfer within a mission is not feasible, however, the **batch mode** gives you the freedom to do that.

The data transfer happens only during mission calculations and in batch jobs. While calculating single points, operating lines, parametric studies etc. the data transfer is disabled.

4.4.3 Export of Results

The results of a mission calculation can be exported directly to **Excel** or to a XLS file. This file can be read by word processors or may be imported to any spreadsheet programs which can read Excel files. These programs offer you a lot of formatting options and thus you can create documents in any style.

4.5 Effect of Small Changes

You can study the effects of small changes in the input parameters on the off-design operating point. Switch on exactly one **limiter** for that purpose.

Note that the magnitude of the effects depends on the flight condition and on the limiter selected. Effects for constant thrust differ from those for constant burner exit temperature or constant spool speed. You can define with the help of composed values arbitrary conditions for which you want to know the effects of small changes.

Effects of compressor efficiency

During cycle design studies any delta efficiency is directly applied to the base compressor efficiency value. During off-design simulations, there are two possibilities for applying a compressor efficiency modifier:

1. Pressure ratio is not affected by the change in efficiency. Consequently the specific work will change with compressor efficiency.
2. The efficiency modifier is applied in such a way that the specific work remains constant and consequently the pressure ratio is affected by the efficiency modifier.

Remember that specific work is connected with the turning of the flow (Euler's equation) when making your choice after clicking the  (*Options*) button in the *Extras* button group:

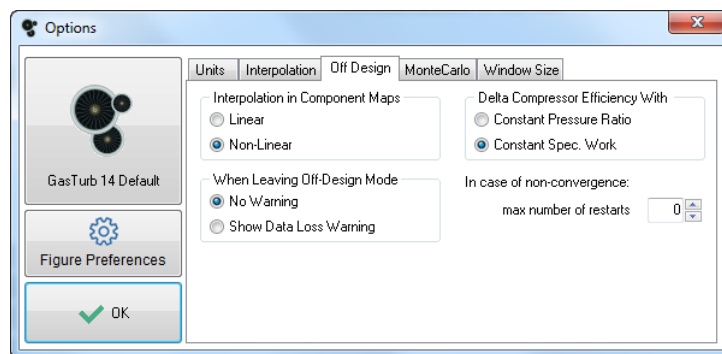
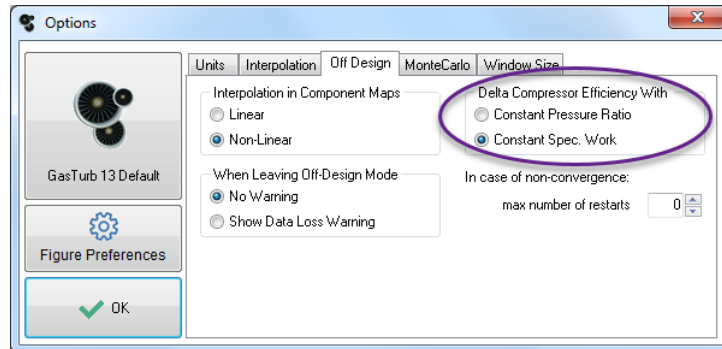

Effects on surge margin

Be careful when looking at the results especially in case of surge margin. The differences are presented as a percentage of the original value. Surge margin is already a value expressed in terms of a percentage, typically 25%. When an effect causes a reduction in surge margin by 2.5% then you will find in the result table the value 10, since 2.5% is 10% of the original value.

4.6 Flight Envelope

You can calculate up to 49 altitude levels and up to 49 speed values in a flight envelope. Select many points if you are interested in the transition between the different limiters. The results of a flight envelope calculation are presented graphically.

If you export the results to Excel, then you can choose to export only the max performance points or the whole operating line for each altitude/Mach number combination. Step sizes in operating lines can be equal gas generator spool speed steps or equal thrust/shaft power steps.

The control laws for the engine must be set before calculating a flight envelope. Define control schedules or set the maximum limits for the various parameters. For the turbojet demo example (file Demo_jet.CYC) you could use the following settings, for example:



	Value	Setting	On/Off	
Spool Speed NH [%]	100,0	100	On	<input checked="" type="checkbox"/>
Corr Spool Speed NHR [%]	100,0	105	On	<input checked="" type="checkbox"/>
Comp Exit Temperature T3 [K]	630	690	On	<input checked="" type="checkbox"/>
Compr Exit Pressure P3 [kPa]	1204	1400	On	<input checked="" type="checkbox"/>
Turb Rotor Inl Temp T41 [K]	1411	0	Off	<input type="checkbox"/>
Turb Exit Temperature T5 [K]	1091	1100	On	<input checked="" type="checkbox"/>
Fuel Flow [kg/s]	0,6619	0	Off	<input type="checkbox"/>
Net Thrust [kN]	26,3737	0	Off	<input type="checkbox"/>
Engine Pressure Ratio EPR	3,6623	0	Off	<input type="checkbox"/>

The default plot parameter selection for the flight envelope indicates where which of the limiters is active.

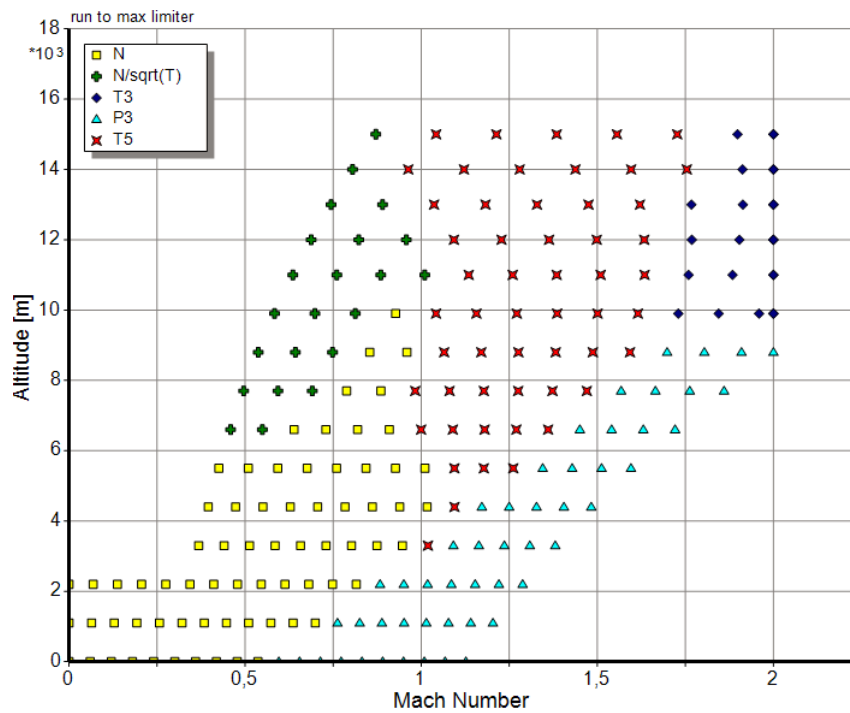

Other results can be shown as contour lines in the flight envelope. Here is an example of a contour line plot with compressor surge margin:

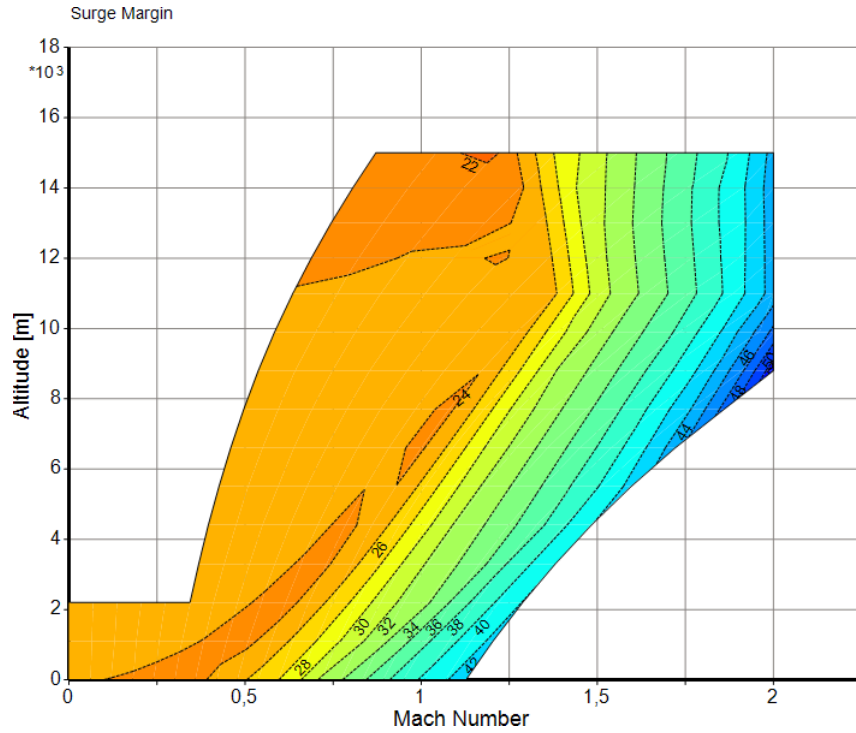

Note that in the x-y pictures with flight envelope data the calculated points are connected linearly. This is because the changeover from one limiter to another can result in sharp bends in the curves. If the program were to use splines to connect the points there, which is an option in other graphs produced by GasTurb 13, the sharp bends would be hidden.

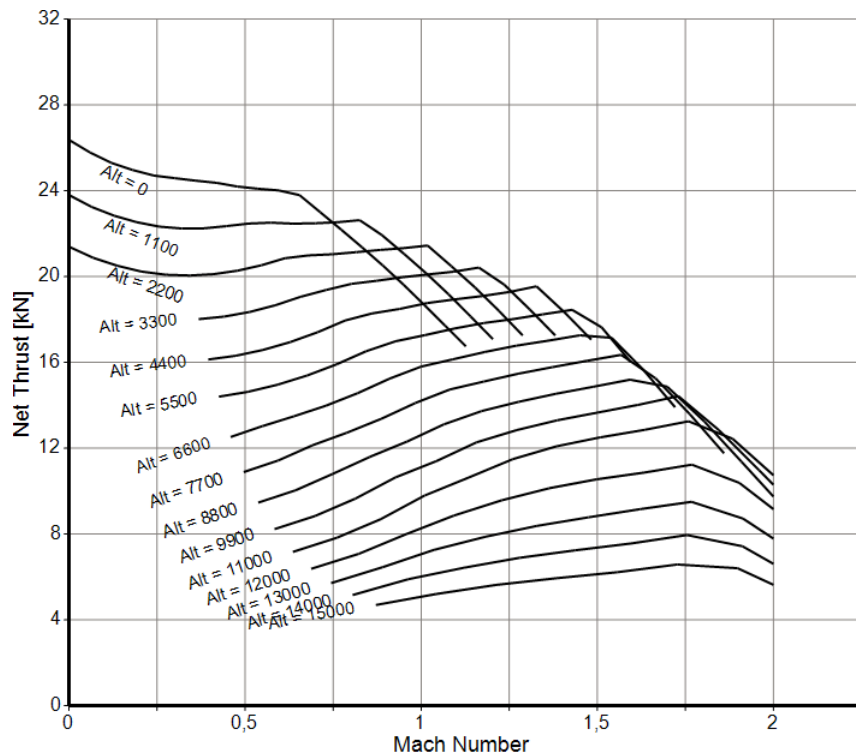



4.7 Calibrating a Model

4.7.1 Test Data

Sometimes you have data from literature or data which were produced with another performance program like GSP, PROOSIS or NPSS. Measured data taken during the operation of a gas turbine or in a pass-off test in an engine maintenance shop are very well suited for calibrating a performance simulation. Wherever your data come from: in the following we will call them **test data**.

Present the test data in the same picture together with the GasTurb 13 results and see clearly the differences. You can immediately draw conclusions and adjust the model in such a way that it agrees with the data - provided they are realistic and consistent with the laws of physics.

The test data must be stored in a ASCII file with the file name extension tst (file name example: PassOff.tst). Import the file after clicking the *Read Test Data* button in the *Compare* button group of the *Operating Line* window.

4.7.2 Test Data File Format

The names assigned to the test data must adhere the GasTurb 13 nomenclature. See which names are valid for a specific engine configuration in the list of the [composed value](#) definition window.

The file format is as follows:

- Any number of blank lines are allowed at the beginning of the file.
- A headline must follow. The headline text will be shown in the pictures with test data.
- The next non-blank line must contain the [short names](#) of the given quantities. Up to 49 quantities are allowed, separated by at least one blank from each other. All names must be on the same line.
- Then two optional lines may follow. The first of these two optional lines contains the keyword *Tolerances*. On the second line the measurement tolerances are given as percentage. The numbers must be separated by at least one blank. Measurement tolerances are shown in figures as ellipsis around the data points.
- On the next lines the data must follow, separated by at least one blank from each other. All data belonging together must be on the same line. At the end of the line there may be some text (beginning with //) describing the meaning of the data on this line. This text will be shown in graphics near to the symbols.
- Before, between and after the data lines are blank lines allowed.
- The sequence of the data lines is of no significance.

Here is an example file with test data from a turboshaft:

```
test ABC
WF      W2      P3      T3      PWSD
Tolerances
0.2     0.5     0.3     0.2     0.7

0.5073  57.21   561.3   467.0   0.0     //Idle
0.6888  72.05   736.4   529.4   2927.2
0.8810  86.38   879.8   560.4   5854.7
0.9665  90.78   931.5   570.4   8782.2
1.0109  99.33   1035.0  588.7   11710
1.2388  106.08  1117.7  602.5   14637
1.3893  112.92  1201.8  614.8   17564
1.5515  119.37  1383.9  627.6   20492
1.7142  124.56  1456.3  639.4   23420  //Max Cont
```

```
1.8402 128.33 1412.1 648.7 26347 //Take off
1.9471 131.64 1457.6 656.5 29274
```

When you have data from two different engines, then you can add the engine designation (B5 and A3, for example) after the two back slashes in the respective lines as comments. Let us assume that engine B3 is a new engine and A5 a deteriorated one. You can run two operating lines, one for each of the engines. Use B5 as title for the first operating line and A3 for the second. Describe with modifiers in the second operating line input the expected deterioration.

If the operating line title is the same as the comments in the test data file, then the symbols in the pictures will be the same for the test data and the related simulation.

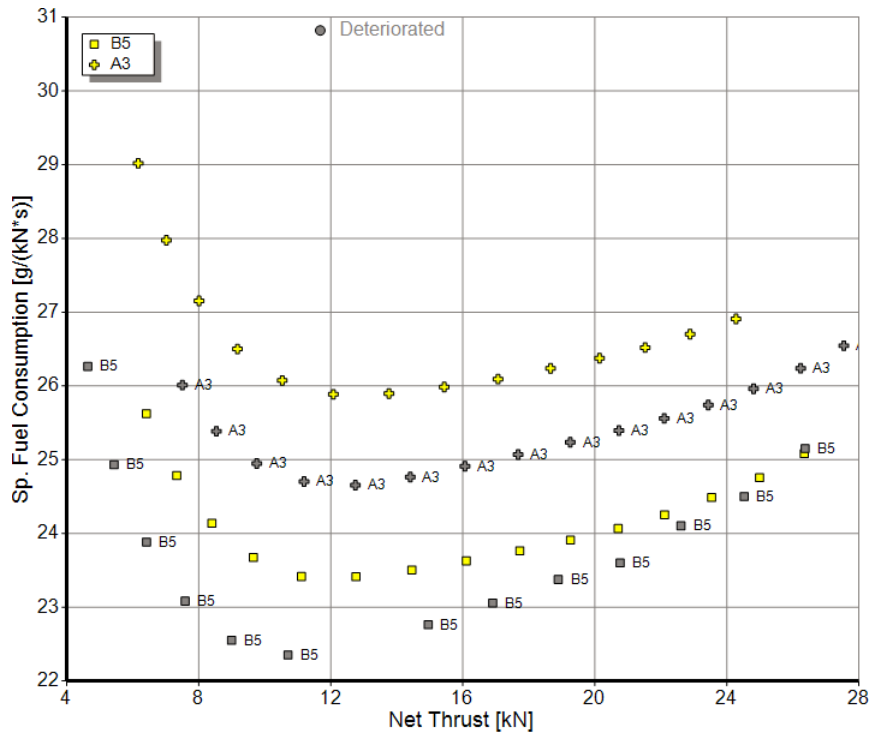

4.7.3 Data Enrichment

Let us consider the case where you have made measurements at several operating conditions while the engine is running. Most of the directly measured data are either pressures, temperatures or spool speeds. Additionally there are measured values for thrust (respectively power) and fuel mass flow. Air mass flow is an indirect measurement which is derived from total and static pressure, bellmouth or venturi area and total temperature. In the end a well calibrated model agrees within measurement tolerances with all these data.

The directly measured data are not all helpful in the model calibration process. Adapting a model requires the adjustment of derived properties like component efficiencies, pressure ratios, corrected mass flows and spool speeds. Comparison of the model with reality and drawing conclusions from differences is much easier if these indirectly measured quantities are added to the test data set.

Note that the indirect test data must be calculated with the same methodology as it is used in GasTurb 13. Otherwise the comparison with the simulation is compromised. For example, calculating compressor efficiency with Excel is inaccurate when the gas property model is different to that used in GasTurb 13.

The solution to this problem is: calculate the indirect test data within GasTurb 13 which is easy with the composed values. Read the test data first and then click the *Enrich Data* button; the *Composed Value Definition* window will open. Click the Add Test Data button and then all the properties in your



tst-file are inserted three lines after the last already defined composed value. The property names are amended with `_tst=` followed by the measured value of the first test data line. The begin and end of the inserted test data is marked in the comment column.

cp_val17	A9qA8Sched=f3[x=P8qamb;par=A8]	
cp_val18	Undefined	
cp_val19	Undefined	
cp_val20	Undefined	
cp_val21	NL_perc_tst=40.03	Begin of tst data
cp_val22	NH_perc_tst=68.52	
cp_val23	P3q2_tst=4.188	
cp_val24	P13_tst=122.65	
cp_val25	P21_tst=127.31	
cp_val26	P3_tst=424.35	
cp_val27	P5_tst=108.78	
cp_val28	Ps7_HS_tst=101.98	
cp_val29	A8_tst=0.308	
cp_val30	T13_tst=311.52	
cp_val31	T21_tst=316.11	
cp_val32	T3_tst=466.36	
cp_val33	T5_tst=576.63	
cp_val34	WF_tst=0.11997	
cp_val35	THP3_tst=399.16	
cp_val36	W2Rstd_tst=23.843	
cp_val37	FN_tst=2.33	
cp_val38	SFC_tst=51.48	End of tst data
cp_val39	Undefined	
cp_val40	Undefined	
cp_val41	Undefined	

In the lines after "End of tst data" you can define composed values for which the added test data are further processed. This results in additional information, the **indirect test data**.

You can enrich your test data with values for the overall pressure ratio, for example. Use as name for the new composed value the **short name** of the overall pressure ratio (which is P3q2) and amend it with `"_tst"`. This indicates that the result shall be added to the test data. If P3_tst is already among the test data, then the following composed value definition yields indirect test data for the overall pressure ratio:

$$P3q2_tst = P3_tst / P2$$

Calculate more pressure ratios, the compressor efficiencies and corrected spool speeds in that way. All composed values with the name ending `"_tst"` are added to the test data.

Another helpful data enrichment method creates a sort of **hybrid test data**. Hybrid data are interpolated values from a correlation within the model, read at a given directly or indirectly measured value. Take as an example the HPC inlet corrected flow W25Rstd which is never a measured value, but needed for placing an operating point in the HPC map. Running the model creates the correlation between overall pressure ratio P3/P2 and W25Rstd. You get a hybrid value for W25Rstd by reading the correlation $W25Rstd=f(P3/P2)$ with the indirect test value of P3/P2 when you define a composed value as

$$\text{Interpolate}[W25Rstd;P3q2_tst]$$

A call of the function *Interpolate[model property name, test property name]* creates a hybrid test value for the model property name. The first call parameter in *Interpolate* - the model property name - must be a valid output property name of your model. The second call parameter - the test data property name - must end with `_tst`. The result of the interpolation is added to the test data and gets the model property name amended by `_tst` (in the example: W25Rstd_tst).

The program calculates indirect and hybrid test data before the composed value window is closed. The names and numbers of the indirect and hybrid test data are added to the other test data. You can save the enriched test data to a tst file after the composed value definition window is closed.

In the beginning of a model calibration process the accuracy of the hybrid test data is limited. Update the hybrid test data from time to time while working on your model. Open the composed value definition window with a click on the *Enrich Test Data* button. The hybrid test data will be newly calculated when you close this window.

In the end - when the calibrated model lines up with all the directly measured pressures, temperatures, mass flows, thrust (respectively power) and spool speeds - the accuracy of the hybrid data will be as good as that of all other test data.

4.8 Monte Carlo Simulations

In the following some typical examples for the application of the Monte Carlo method to engine off-design problems are discussed. GasTurb 13 has a limited capability for statistically analyzing the results which is, however, sufficient for most - if not all - performance problems. For a more detailed analysis the output can be directed to [Excel](#) which has a wide range of statistical analysis tools incorporated.

4.8.1 Manufacturing Tolerance

Gas turbine manufacturers typically quote engine performance with margins to account for engine-to-engine variation, which is based on historical trending of production performance experience. The production margins deal with parts and control tolerances and do not address performance uncertainty in the design of the components. Therefore the performance program employed for a production tolerance Monte Carlo simulation must be operated in off-design mode.

The results of a production tolerance study are - among others - statistical distributions for specific fuel consumption, thrust, air flow and turbine temperature. All these performance metrics may be presented as confidence levels.

The input for a Monte Carlo study about production tolerances are a model of the average engine combined with statistically distributed modifiers of the component efficiencies and flow capacities. Note that not all of these modifiers are independent from each other. A compressor with poor efficiency will usually also show low flow capacity, for example. In GasTurb 13 this dependence between compressor efficiency modifier and flow modifier is automatically taken into account.

Moreover, there is dependence between compressor flow and pressure ratio. The map of a compressor with a low flow capacity can be approximated by scaling the nominal map both in flow and pressure ratio downwards. Also this effect is automatically taken into account when using GasTurb 13 for the production tolerance Monte Carlo study.

With turbines there is normally no correlation between flow capacity and efficiency. The statistical distribution of the turbine flow capacity modifier is independent from the distribution of the efficiency modifier.

4.8.2 Engine Test with Control System Interaction

There are cases in which the control system interferes with the pass-off test and limits one or more of the engine parameters like the mechanical spool speed, for example. Note that the statistical distribution of the parameter which is limited does not only depend on the control sensor tolerance.



The scheduled value may depend on measured parameters like T_2 or others and thus the tolerances of the schedule parameters have an influence on the resulting spool speed scatter, for example.

Moreover, some engines from a production batch might be temperature limited, others spool speed limited. In such a case there exists a highly non-linear correlation between the input parameters and the result. Applying the **Root-Sum-Squared** method to such problems will definitely yield an incorrect result. Only a Monte Carlo study employing a representative engine performance model which includes the control schedules and the sensors can provide correct numbers for the statistical distribution of the limited parameters.

4.9 Model Based Test Analysis

The conventional test analysis makes no use of information which is available from component rig tests, for example. It will give no information about the reason, why a component behaves badly. A low efficiency for the fan may be either the result of operating the fan at aerodynamic overspeed or a poor blade design. To improve the analysis quality in this respect is the aim of „**Analysis by Synthesis**“ (**AnSyn**). This method is also known as model based engine test analysis.

When doing analysis by synthesis a model of the engine is automatically matched to the test data. This is done with scaling factors applied to the mass flow and efficiency of the components that close the gap between the measured data and the model. The deviations from the model are described with the **AnSyn Factors**. A factor of 1.0 means perfect agreement between the model and the measurement. An efficiency scaling factor greater than one indicates, that the component performs better than predicted, for example.

For each engine configuration GasTurb 13 assumes that certain measurements are available, see for example the [turbojet](#) and the [turboshaft](#) testbed.

4.9.1 Turbojet Testbed

The schematic below shows a turbojet engine installed in an altitude test facility. The measurements which GasTurb 13 uses with the model based test analysis are marked. If not all of these measurements are available then some assumptions about the test vehicle must be made.

Turbojet Testbed

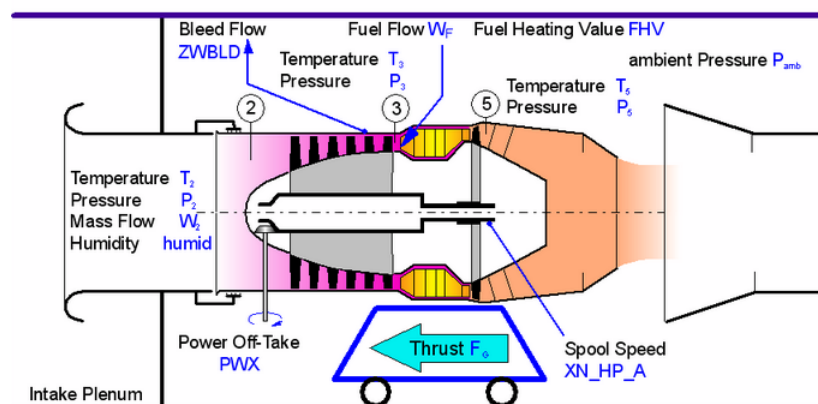

4.9.2 Turboshaft Testbed

The schematic below shows a turboshaft engine installed in a test facility. The measurements which GasTurb 13 uses with the model based test analysis are marked. If not all of these measurements are available then some assumptions about the test vehicle must be made.

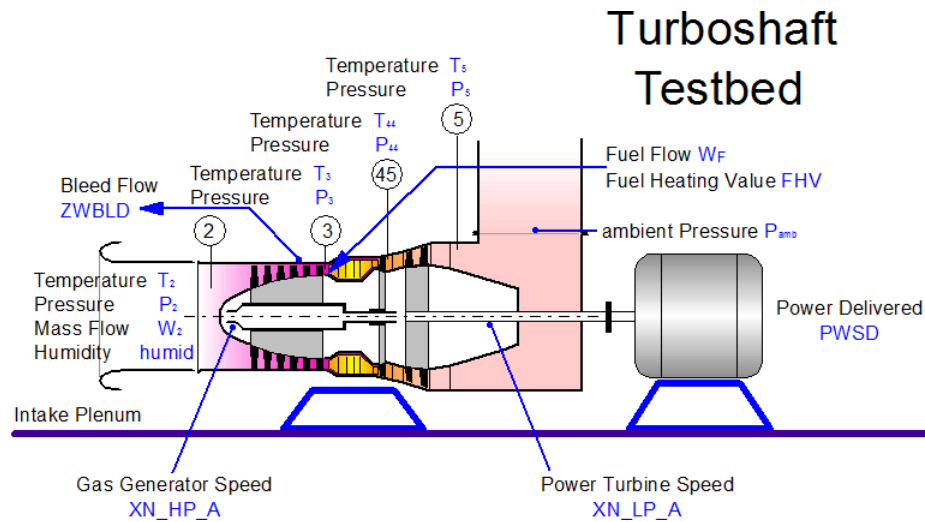

4.9.3 Compressor Performance Analysis

The model of the compressor is a calculated or measured map which contains pressure ratio over corrected flow for many values of corrected spool speed N/\sqrt{T} . During the test analysis process we obtain from the measurements the pressure ratio, the corrected mass flow, the efficiency and the corrected spool speed. Normally we will find, that the point in the map defined by the measured pressure ratio and the measured corrected flow (marked in the figure by the open circle) will not be on the line for N/\sqrt{T} in the original map.

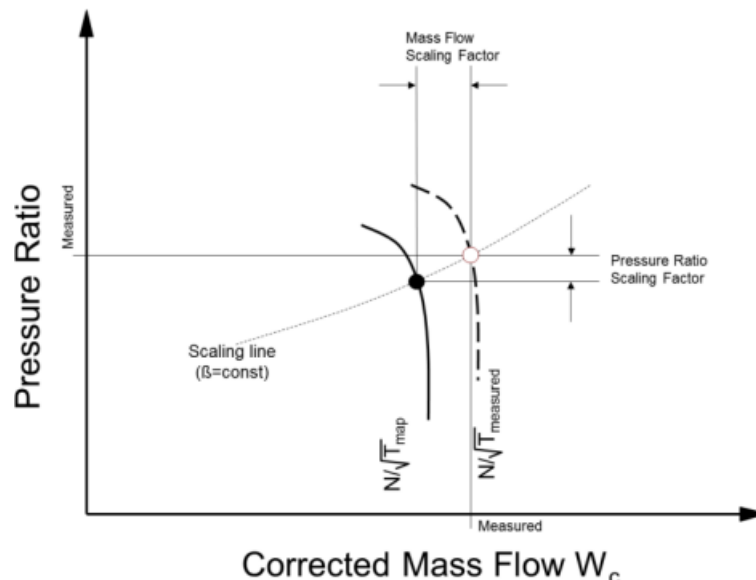

We can shift the line marked N/\sqrt{T}_{map} in such a way, that it passes through the open circle. This is done along a scaling line which connects the open circle with the solid circle. The distance between the two circles can be described by the mass flow and the pressure ratio scaling factors. The efficiency scaling factor compares the analyzed efficiency with the value read from the map at the solid point.



There are many ways to select a scaling line. In GasTurb 13 the [auxiliary map coordinate \$\beta\$](#) is used as a scaling line because this makes the calculations simple. Along the scaling line there is a correlation between the mass flow [scaling factor](#) and the pressure ratio scaling factor. Therefore it is sufficient to use the mass flow scaling factor alone. The pressure ratio scaling factor is calculated from the mass flow scaling factor from the rule $\beta = \text{constant}$.

4.9.4 Single Point Data Input

Single point data input is placed on the first page of the notebook. Have a look at the example data from a turboshaft:

Test Data	Turbine(s)	Air System	Nominal Conditions	Deviations from Model	Model Parameters	Sensor Check
Sensor				unit	value	tolerance [%]
Scan Identification No.					6	1
Meas. Rel.Humidity @ T2&P2 [%]					0	1
Meas. Mass Flow W2				kg/s	2,9	0,3
Meas. HP Spool Speed [RPM]					37240	0,2
meas. PT Spool Speed [RPM]					20000	0,2
Meas. Inlet Temperature T2				K	310	0,1
Meas. Inlet Pressure P2				kPa	95	0,1
Meas. Compr.Exit Temp. T3				K	682,07	0,3
Meas. Comp. Exit Press. P3				kPa	1111,34	0,2
Meas. Fuel Flow WF				kg/s	0,06429	0,2
Meas. HPT Exit Press. P44				kPa	286,149	0,4
Meas. HPT Exit Temp. T44				K	1144,41	0,8
Meas. Turb. Exit Press. P5				kPa	102,039	0,4
Meas. Turb. Exit Temp. T5				K	926,07	0,8
Meas. Amb. Pressure Pamb				kPa	98	0,1
Meas. Shaft Power				kW	729,2	0,5
Meas. Bleed Mass Flow				kg/s	0	1
Meas. Fuel Heating Value				MJ/kg	43,124	0,1
Measurement X1					0	1
Measurement X2					0	1
Measurement X3					0	1

You can play with these data, modify some of them and see what the consequences on the analysis result shown on the page *Deviations from Model* are. Try also a change to one single value and run the sensor checking algorithm.

The measurement *tolerance* (last column on the test data page) is used for:

- [checking the sensors](#).
- [creating a file](#) with fake measured data that follow a normal distribution with the standard deviation equal to the measurement tolerance (click (*Example*) in the *Additional* button group)

If you do not have sensors for a quantity which is on the single point data input page then you can use an iteration to find an appropriate value. For example, if no T₃ sensor is available, you can iterate the measured value of T₃ in such a way that the compressor efficiency *AnSyn Factor* is equal to 1.0 (or 0.99 in case you know that the compressor is deficient, for example).

At the end of the list there are three measurements X1, X2 and X3 that may be used for quantities that are not part of the list. Enter an additional measured value as *Measurement X1*. Employ a composed value and write, for example, *myValue=X1Mea*. Now you can use *myValue* as iteration target and any of the model input parameters as iteration variable.

4.9.5 Turbine Capacity

Turbine flow capacity can be specified in percent on the second notebook page in the test analysis window. A flow capacity of 100% describes the value of the average engine.

Test Data	Turbine(s)	Air System	Nominal Conditions	Deviations from Model	Model Parameters	Sensor Check
Meas. HPT Flow Area [%]					100	
Meas. Power Turb. Flow Area [%]					100	

4.9.6 Test Vehicle Air System

It might be known that the air system of the test vehicle differs from that of the nominal simulation model. This can be taken into account by adapting the Air System data.

Test Data	Turbine(s)	Air System	Nominal Conditions	Deviations from Model	Model Parameters	Sensor Check	
Rel. Handling Bleed						0	
Rel. Enthalpy of Handling Bleed						1	
Rel. Overboard Bleed W_Bld/W2						0,005	
Rel. Enthalpy of Overb. Bleed						1	
Recirculating Bleed W_reciW2						0	
Rel. Enthalpy of Recirc Bleed						1	
Number of HP Turbine Stages						1	
HPT NGV 1 Cooling Air / W2						0	
HPT Rotor 1 Cooling Air / W2						0,05	
HPT NGV 2 Cooling Air / W2						0	
HPT Rotor 2 Cooling Air / W2						0	
HPT Cooling Air Pumping Dia						m	0
Rel. Enth. PT NGV Cooling Air						0,6	
Rel. Enth. PT Cooling Air						0,6	
Rel. HP Leakage to PT exit						0	
Number of PT Stages						2	
PT NGV 1 Cooling Air / W2						0	
PT Rotor 1 Cooling Air / W2						0	
PT NGV 2 Cooling Air / W2						0	
PT Rotor 2 Cooling Air / W2						0,01	

4.9.7 Flow Analysis Method

The mass flow through an engine can be directly measured or analyzed from various other measurements. For a single spool turboshaft, for example, the compressor mass flow can be calculated from the turbine flow capacity or from the measured exit temperature T_5 when fuel flow is known.

The following flow analysis methods are offered for 2 SPOOL TURBOSHAFT engines:

Flow Analysis Method

- W2 as measured
- HP Turbine Capacity
- LP Turbine Capacity
- T45 Heat Balance
- T5 Heat Balance

GasTurb 13 offers for each engine configuration a selection of mass flow analysis methods. The method which provides the most reasonable test analysis result depends on the accuracy of the sensors. Check the effects of sensor errors on the analysis result with a click on the  (*Sensitivity*) button in the *Check* button group.



4.9.8 Deviations from Model

Running a single point test analysis by synthesis yields the data shown in the table headed Deviations from Model:

Test Data	Turbine(s)	Air System	Nominal Conditions	Deviations from Model	Model Parameters	Sensor Check
Compressor Flow Factor				1,01687		
Compressor Efficiency Factor				0,998543		
HP Turbine Flow Factor				0,997274		
HP Turbine Efficiency Factor				0,970016		
Power Turbine Flow Factor				1,00358		
Power Turbine Efficiency Factor				0,970018		
T45 measured - T45 calculated			K	-8,79459		
T5 measured - T5 calculated			K	-8,99868		
				0.9	1	1.1
				-50	0	50

The factors in the table are the **AnSyn Factors** that describe the difference between the test vehicle and the simulation model.

4.9.9 Thrust Facility Modifier

The force measured in a sea level testbed is less than the true static thrust of the engine. This is mainly due to the inlet momentum, the product of airflow and approach velocity in front of the engine. Cradle drag and other forces caused by the secondary flow around the engine are generally much smaller than the inlet momentum.

GasTurb 13 can calculate the inlet momentum from an estimated stream tube diameter. This allows for an approximate thrust correction when calculating the *Thrust AnSyn Factor*. To enable this, the *Thrust Correction* must be activated and a value for the *Stream Tube 0 Diam* must be prescribed. Changes of the diameter at partload can be prescribed by means of the factor *Partload Factor*, where the following formula applies:

$$\text{Cell Inlet Momentum} = \frac{(\text{Inlet Mass Flow})^2}{\pi \cdot \text{Inlet Density} \cdot (\text{Stream Tube Diameter} / 2)^2}$$

$$\text{Stream Tube Diameter} = \text{Stream Tube 0 Diameter} \cdot (1 + \text{Partload Factor} \cdot (1 - \text{Rel Corr. LPC Speed}))$$

In practice, a thrust facility modifier closes the gap between the measured force and thrust. Thrust facility modifiers are determined during an official testbed calibration exercise and usually described with polynomials which are a function of corrected spool speed. These polynomials are only valid within a limited thrust range. Applying them outside the calibrated thrust range is not advisable.

The better solution is to determine a representative stream tube diameter, which must be selected in a way such that the inlet momentum is equivalent to the thrust facility modifiers from the official calibration report. This allows for the calculation of the inlet momentum – the thrust facility modifier – for any thrust, which will yield more accurate results than applying the polynomial outside its calibrated thrust range.

4.9.10 Multiple Point Data Input

Test data for multiple points can be read from a file with the extension **.MEA**. The file format is as follows



ScanId	humid!	w2!	XN_LP_A!	XN_HP_A!	T2!	P2!	
Tolerances							
0	10	0.5	0.03	0.03	0.2	0.3	
Measured Data							
10	60	182.5	100.0	100.0	288.15	14.696	// A: Take Off
11	60	180.2	99.0	99.5	287.35	14.699	// A: Max Cont
13	60	172.5	96.0	99.1	289.75	14.655	// A: Cruise 1
14	60	164.1	89.3	97.8	288.05	14.667	// A: Cruise 2
20	60	182.3	100.0	100.0	288.35	14.523	// B: Take Off
21	60	180.0	99.0	99.6	287.25	14.577	// B: Max Cont
23	60	173.5	96.0	99.15	289.0	14.566	// B: Cruise 1
24	60	164.7	89.3	97.82	288.17	14.573	// B: Cruise 2

The first line must begin with *ScanId* followed by the **short names** of all measured data that are defined for the selected engine configuration. The next two lines (printed blue) are optional. They give the tolerances for the measurements in percent of the actual value.

The key words *Measured Data* precede the lines with the measured data. The number of scans is limited to 50. If more than 50 scans are in the file, then only the first 50 scans will be read.

After the last number in a line you can optionally add a descriptive comment which must be preceded by *//*. If you use for several data points the same comment, then these points will be connected with dashed lines in the graphical output if the description box is hidden.

You can create an example file with 25 fake sets of measured data by clicking the  (*Example*) button in the *Additional* button group. The data in this example file will be based on the measured data shown on the *Test Data* page. The numbers follow a normal distribution with the standard deviation equal to the measurement tolerance.

After having read a file with measured data switch to the *Test Data* page and scroll through the file by selecting the *Scan Sequence Number* of interest. Perform the model based test analysis point by point, do *ISA* and *Schedule* corrections and have a look at the details of the cycle (click  (*Details*) in the *Output* button group). Try also a click on  (*Model*) and **check graphically** how much the measured data deviate from those of the model.

4.9.11 Sensor Checking

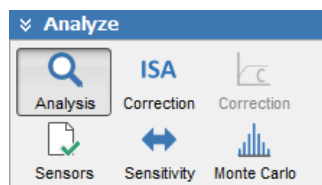

The interpretation of measurements poses always the question: is the sensor inaccurate or a component of the gas turbine degraded? The option *Check Sensors* in GasTurb 13 tries to answer this question with the help of AnSyn as described in the following.

It is assumed, that only one sensor is inaccurate. At first the sum of the absolute deviations of all **AnSyn factors** from 1 is calculated:

$$q_0 = \sum (f_{health} - 1)^2$$

Next for each of the sensors an optimization is done in which the optimization variable is the sensor reading and the figure of merit is:

$$fom = \sum (f_{health} - 1)^2$$



Thus for sensor i a theoretical reading $r_{i,opt}$ is found together with the figure of merit $fom_{i,opt}$. With other words, if the sensor would indicate the reading $r_{i,opt}$ then the deviations of all health factors from 1 would be minimal.

When all optimizations are finished, then the differences $d_{i,opt} = q_0 - fom_{i,opt}$ are checked. A big difference means that ignoring the reading of sensor i would improve the agreement between the model and all the other sensor readings significantly. The hypothesis of the sensor checking algorithm is that the sensor for which $d_{i,opt}$ has the highest value is potentially indicating the wrong value. Note, however, if the measured value r_i deviates less than the measurement tolerance from the theoretical reading $r_{i,opt}$ then no sensor error can be diagnosed.

Note that the magnitude of the AnSyn Factors depends on the [flow analysis method](#). Therefore the result of a sensor check depends also on the mass flow analysis method selected.

4.9.12 ISA Correction

The purpose of correcting measured data from a gas turbine test is to make the results comparable with those from other engines or with acceptance test criteria, for example. The basic question to be answered is: What would be the engine performance if the test would have been at *Standard Day* conditions? This question applies not only to measurements taken on a normal test bed where the local altitude and the weather conditions dictate the conditions of the incoming air but also to experiments in an altitude test facility (ATF) if, due to facility limitations, the conditions at the engine face are not as desired, for example.

Data correction algorithms are applied also when monitoring engine deterioration: it is essential to compare data which have been corrected to the same ambient conditions.

The intent with the gas turbine parameter correction is maintaining the flow field similarity in terms of Mach numbers everywhere in the engine which in turn requires invariant geometry. Due to the variability of the isentropic exponent with temperature (and due to other reasons) strict Mach number similarity is not feasible in any of the components of a gas turbine. The deviations from the ideal case within each of the components cause the re-matching of the cycle which in turn moves the operating points in each of the component maps a little bit and this modifies the shape of the flow field.

The correction of the measured values to *ISA Standard Day* conditions is very easy if the AnSyn approach is used. Click [ISA \(Correction\)](#) in the *Analyse* button group for that. The scaling factors found from the analysis of the test data are applied to the model and then the model is run at the same corrected low-pressure spool speed and the ISA engine inlet conditions. Single spool turboshaft engines used for power generation or driving a propeller are a special case: the model is run at the same mechanical spool speed as tested because the generator (respectively propeller) driven by the gas turbine always must run at constant mechanical spool speed.

The precise operating condition for the ISA correction is specified on the *Nominal Conditions* page:

Test Data	Turbine(s)	Air System	Nominal Conditions	Deviations from Model	Model Parameters	Sensor Check
Altitude				m	0	
Delta T from ISA				K	0	
Relative Humidity [%]					0	
Mach Number					0	
Fuel Heating Value				MJ/kg	43,124	
Overboard Bleed				kg/s	0	
Power Offtake				kW	30	

The operating points in the component maps of a turbofan engine will not be exactly the same for both the test and the calculation of the ISA corrected performance. During the ISA correction the N/\sqrt{T} will be held constant and the corrected high-pressure spool speed will be a result. It will be

only very near to (but not exactly the same as) the measured value. The reason for that are the many small effects which do not allow strict Mach number similarity between the tested and the ISA corrected cases like

- gearbox drag
- fuel, oil and hydraulic pump power
- changes in gas properties
- Reynolds number effects
- thermal expansion of rotors, blades and casings

4.9.13 Schedule Correction

With the AnSyn approach one can easily evaluate the rated performance by running the calibrated model (the model with the scaling factors applied) at rated power. The rated power is defined by the control schedules with $T_5=f(T_2)$, for example. Therefore the correction to rated power is called *Schedule Correction*.

If the test was done for checking the engine performance at *Maximum Power*, for example, then after the [ISA Correction](#) a further parameter correction step is required. "Rated Power" is implemented in the control system as a maximum permitted value for a property which is calculated from control system inputs. The controlled parameter can be a temperature, a pressure or a spool speed, and the value which defines the rating often is a function of T_2 , P_2 and flight Mach number.



During the test the control system might prevent that the same corrected spool speed as achievable on a *Standard Day*. This is quite normal if the test is done while the ambient temperature is higher than the *Standard Day* temperature and a turbine temperature limit is hit. To derive from such a test the rated performance of an engine on a *Standard Day* is very simple and straightforward with the model based parameter correction. The model, which was calibrated using the measured data in step one of the procedure is run with *Standard Day* inlet and exhaust conditions at rated power, and this yields the rated performance.

Click  (*Correction*) in the *Analyse* button group for running the model in such a way that it takes all control system actions into account like scheduling the variable geometry, for example. Note that this menu option is available only if you have defined maximum [limiters](#) before switching to test analysis.

Of course all details that were during the test for some reason different from the nominal values can be taken into account, like, for example, bleed air and power offtake or the power turbine spool speed. If during a test in the altitude test facility the desired flight condition could not be simulated due to facility limitations then this can also be corrected. Even emission data – which might be of interest with water and steam injection - can be corrected provided the model includes such detail.

4.9.14 Effect of Measurement Errors

If a sensor is indicating a wrong value, then this will have consequences on the analysis result, i.e. the calculated AnSyn Factors. The sensitivity of these factors to measurement errors depends on the [Flow Analysis Method](#).

The effects of the measurement scatter can be studied by selecting  (*Sensitivity*) in the *Check* button group. The result is a table with influence factors. The step size is given with the measurement tolerance. Alternatively the effects of measurement errors can be evaluated with a Monte Carlo study (select  (*Monte Carlo*)) which allows a statistical analysis of the scatter in the AnSyn Factors caused by the scatter in the measurements.



In such a dedicated Monte Carlo simulation only the measured data are offered for applying a statistical distribution which can be either a Gauss distribution or a asymmetric trapezoid distribution. Have a look at the distributions of the AnSyn Factors to see what scatter in measurements can do to the test analysis result.

4.9.15 Comparing a Model with Measured Data

After having read a set of [measured data from a file](#) you can do either test analysis by synthesis or you can compare the measured data with the model.

When comparing measured data directly with a model, then the model will be run automatically in such a way, that T_2 , P_2 , P_{arb} and the gas generator spool speed are as measured. All other measured data will deviate more or less from the model because the model is never perfect. It is a good idea to use [Composed Values](#) when comparing measured data with a model. Plotting the ratio $P25/P25!$ over $W25Rstd$ is much more meaningful than plotting $P25$ over $P25!$, for example.

4.9.16 Data Export

4.9.16.1 Data Output to File

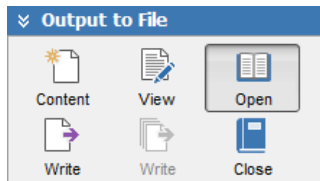

The results from the test analysis can be stored in a file. First you have to define which quantities should be stored in that file, select *Output|Define Output File Content* from the menu in the AnSyn window. Before having defined the output parameter list all the other menu options are grayed out.

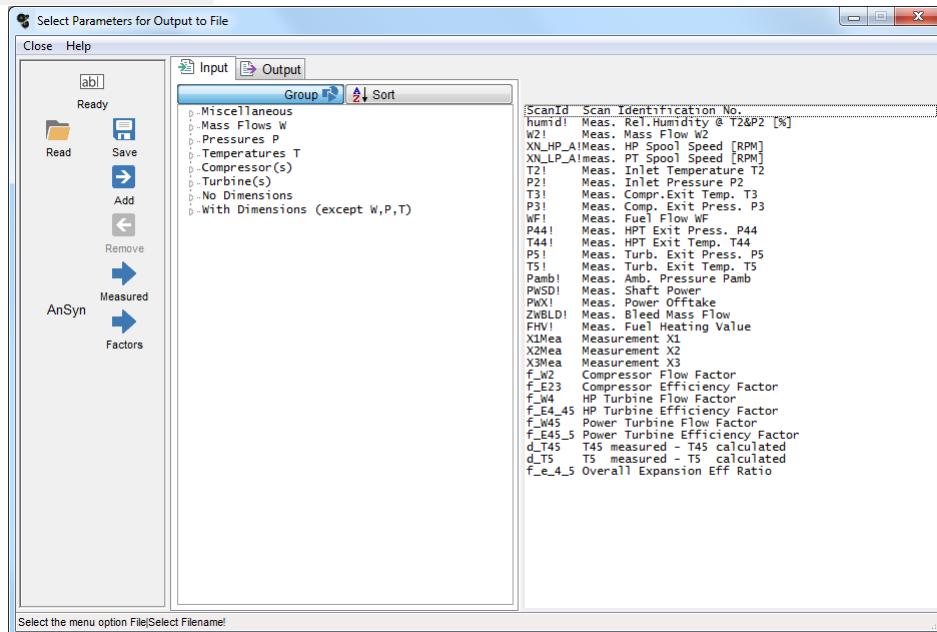

In the output parameter selection window you can pick one property after the other by clicking on a single item or you can transfer whole groups of parameters to the selection list. Be sure to include all calculated data of interest in your export list if you want to store [ISA Corrected](#) or [Schedule Corrected](#) data.





If you are done, click **Ready**. You will be prompted for a file name and then you are ready to write the test results to file. Store the results from a single scan to file or results from all the scans you have read from file. All options from the menu shown above are available, try them!

Note that the calculated numbers that are exported to the file depend on your selection in the *Analyze* button group: clicking  (*Analysis*) will export the data as measured, selecting *ISA* (*Correction*) will write the ISA corrected data to file and a click on  (*Correction*) exports the rated performance.

4.9.16.2 Export To Excel

Initialize the export of test analysis results to *Excel* from the *Output* button group. Be sure to include all calculated data of interest in your export list if you want to store *ISA Corrected* or *Schedule Corrected* data.

After having initialized Excel - and if the  (*Export*) button is down - each time you click  your data selection will be exported to Excel. The data are as tested, *ISA Corrected* or *Schedule Corrected* depending on your momentary selection in the *Analyze* button group.

4.10 Steady State Engine Control

The engine control system determines - dependent on throttle lever angle and several other input signals - fuel flow, variable guide vane settings and bleed valve positions. The system guarantees that the certified spool speeds, temperatures and pressures are not exceeded, both during transient and steady state operation.

The following sections deal with the engine operation during steady state operation, simulations of the *transient* behavior are described later.

4.10.1 Limiters

The engine controller surveys various parameters with the aim of protecting the engine and making sure that it achieves the design life. The controlled parameters can be directly measured values like spool speeds and temperatures, or synthetic values calculated within the control system. How to set and activate limits for one more engine parameters in the simulation is described in the next subsections.

4.10.1.1 Single Limiter Settings

The maximum power available from a given engine depends on several limits such as those of maximum spool speed, maximum temperature or maximum pressure. Which limiter is active depends, among other things, on the flight condition, the amount of power and bleed air offtake. The program can apply several limiters simultaneously. The solution found by iteration will be a cycle with one of the critical parameters being just at its limit. No other limiter will be violated.



	Value	Setting	On/Off	
Spool Speed NH [%]	100,0	101	On	<input checked="" type="checkbox"/>
Corr Spool Speed NHR [%]	100,0	102	On	<input checked="" type="checkbox"/>
Comp Exit Temperature T3 [K]	630	690	Off	<input type="checkbox"/>
Compr Exit Pressure P3 [kPa]	1204	1400	Off	<input type="checkbox"/>
Turb Rotor Inl Temp T41 [K]	1411	1450	On	<input checked="" type="checkbox"/>
Turb Exit Temperature T5 [K]	1091	1100	Off	<input type="checkbox"/>
Fuel Flow [kg/s]	0,6619	0	Off	<input type="checkbox"/>
Net Thrust [kN]	26,3737	0	Off	<input type="checkbox"/>
Engine Pressure Ratio EPR	3,6623	0	Off	<input type="checkbox"/>

Max Limiter Setting options for a turbojet

Maximum limiters can be single values as shown in the *Setting* column of the figure above or read from a [control schedule](#) while minimum limiters are always single values. You can switch on/off the single valued limiters by clicking in the *On/Off* column. Note that all mechanical and aerodynamic speed limits are percentages of the design point data.

Humidity in the air has an effect on the limiters for the corrected spool speeds of compressors. The observed limiter values are calculated from the mechanical spool speed and the inlet temperature only. The compressor maps, however, are read with the fully [corrected spool speed](#) which takes into account the gas constant and thus the effect of humidity. This causes a change in corrected flow with humidity at a constant setting of a corrected spool speed limiter.

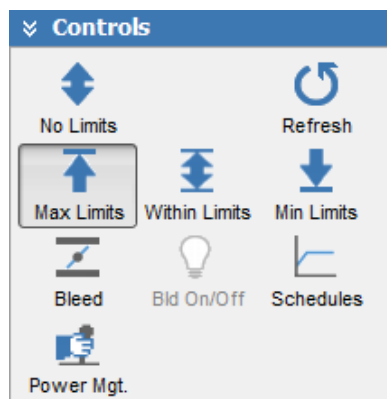

While setting individual limiter values you can test your input with the *Refresh* button. If the *max limits* button is down, then the result will be an operating point which hits one of the maximum limits. Similarly, if the *min limits* button is down, the result will be at one of the specified minimum limits.

If the *within limits* button is down, then first the operating point is calculated as if all limiters would be inactive. This first solution is checked whether it is within the min and max limits; if that is the case then the calculation is finished. If a minimum limiter is violated with the first solution, then the operating point is recalculated with the minimum limiters active and the maximum limiters inactive; this yields a second solution which replaces the

first one. Next it is checked if the solution violates a maximum limit; if that is not the case the calculation is finished. Otherwise the cycle is again recalculated, now with the minimum limiters inactive and the maximum limiters active - this yields the final solution. Note that it can happen that this final solution violates a minimum limit.

Besides the pre-defined limiters - provided you have defined [composed values](#) - you can use up to three of them as additional limiters. Note that drop-down lists with composed values (on the bottom left side of the table above) will appear only if some composed values are defined. Note that composed values employing general tables do not appear in the drop down lists.

It is a good idea to place the definition of the composed values that are employed as limiters (or as iteration targets) at the top of the composed value definition list. This is not a stringent requirement, however, it will speed up the calculation a bit.

There is a [code for the active limiter](#) among the output data which is shown in the mission output list, for example.

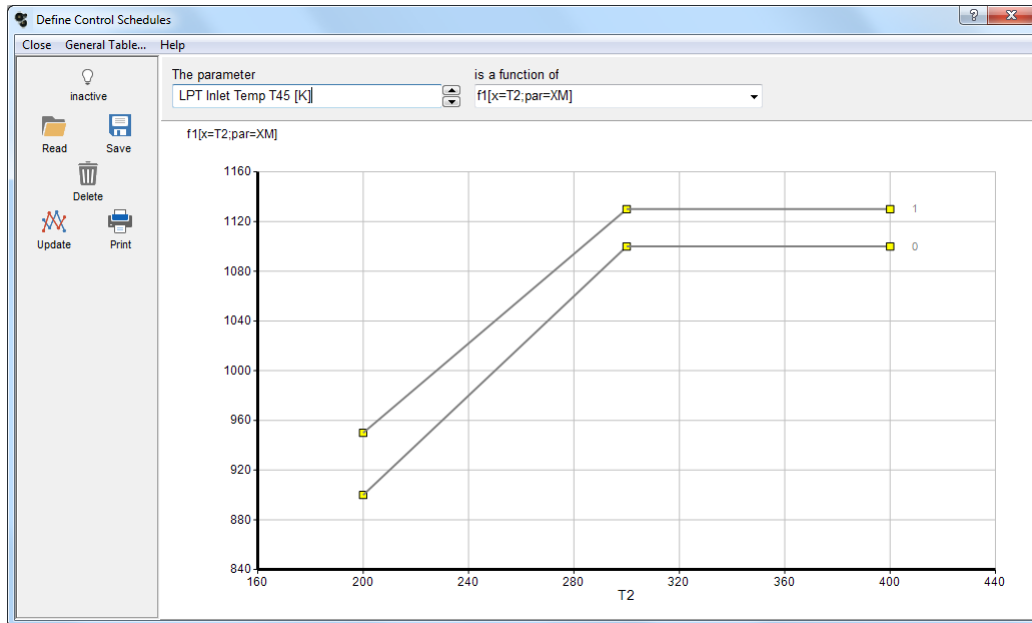

Employing a General Table as schedule

Another way to consider two (or even more) input parameters for a control schedule is to employ [composed values](#). For example, define any composed value to yield $T5/T5_sched$ and use it as a single valued maximum limiter with 1.0 as setting. Similarly you can employ composed value as minimum limiters.

Besides maximum limiter schedules you can also define other control schedules. For example, a nozzle area trim can be made a function of corrected spool speed. The permissible parameter combinations depend on the engine configuration.

4.10.1.3 Limiter Codes

During steady state simulations the following limiter codes are used:

-7	cp_val_min3	value of the third cp_val min limiter
-6	cp_val_min2	value of the second cp_val min limiter
-5	cp_val_min1	value of the second cp_val min limiter
-4	P3	min burner inlet pressure
-3	NHR_min	min corrected gas generator spool speed
-2	WF_min	min fuel flow
-1	NH_min	min gas generator spool speed
1	NH_max	max high-pressure spool speed
2	NHR_max	max corrected high-pressure spool speed
3	T3_max	max burner inlet temperature
4	P3_max	max burner inlet pressure
5	T41_max	max stator outlet temperature (SOT)
6	T45_max	max low-pressure turbine inlet temperature
7	T5_max	max turbine exit temperature
8	NL_max	max low-pressure spool speed
9	NLR_max	max corrected low-pressure spool speed



-7	cp_val_min3	value of the third cp_val min limiter
10	TRQ_max	max torque
11	WF_max	max fuel flow
12	FN_max	max thrust
12	PWSD_max	max shaft power
13	EPR_max	max engine pressure ratio
14	cp_val_max1	value of the first cp_val max limiter
15	cp_val_max2	value of the second cp_val max limiter
16	cp_val_max3	value of the third cp_val max limiter

In transient simulations the [active limiter codes](#) are extended to include additional limits.

4.10.2 Automatic Bleed

For controlling the compressor surge margin you can select an automatic handling bleed. This bleed discharges some of the compressed air into the bypass duct or overboard. You can thus lower the operating line of the compressor and avoid surge. The automatic handling bleed will be modulated between the two switch points that you can specify as described already in the [Getting Started](#) section.

Have a look at the secondary air system picture to see the handling bleed offtake location in your specific example.

4.10.3 Thrust Management

With the methods described in the [Limiter](#) section one can calculate the performance for any steady state operating point. Many details about the parameters that affect the engine performance must be known for that. In the aircraft, however, the pilot does not want (and does not need) to know all the engine control details, he is only interested in thrust and sets his throttle lever to the appropriate position - that's it.

Modern engines all have electronic controllers called FADEC (Full Authority Digital Engine Control), EEC (Electronic Engine Control) or DECU (Digital Engine Control Unit), for example. These controllers contain a complex thrust control logic which guarantees that the necessary thrust is delivered, but not more. Delivering more thrust than required would consume unnecessarily engine life and would lead to increased maintenance cost.

In a generic program like GasTurb 13 one cannot model all fancy control logic features, however, the most typical and most important thrust management methods can be simulated.

There are two basically different thrust management methods: One can either aim for getting the maximum performance from an engine or for getting consistent performance values, independent from engine-to-engine variations caused by manufacturing tolerances and engine deterioration. The first method is typically applied with fighter engines while the second method is used for engines on commercial airliners.

4.10.3.1 Fighter Engines

Fighter engines are controlled in such a way that they give the pilot the maximum possible thrust. Each individual engine is run to its limits. Dependent on the flight condition, exhaust gas temperature



T_{45} , compressor exit temperature T_3 , true or corrected spool speeds etc. limit the maximum thrust that can be generated. Engines with this control philosophy are called "**fully rated**" engines.

There are single valued limits as well as scheduled ones.

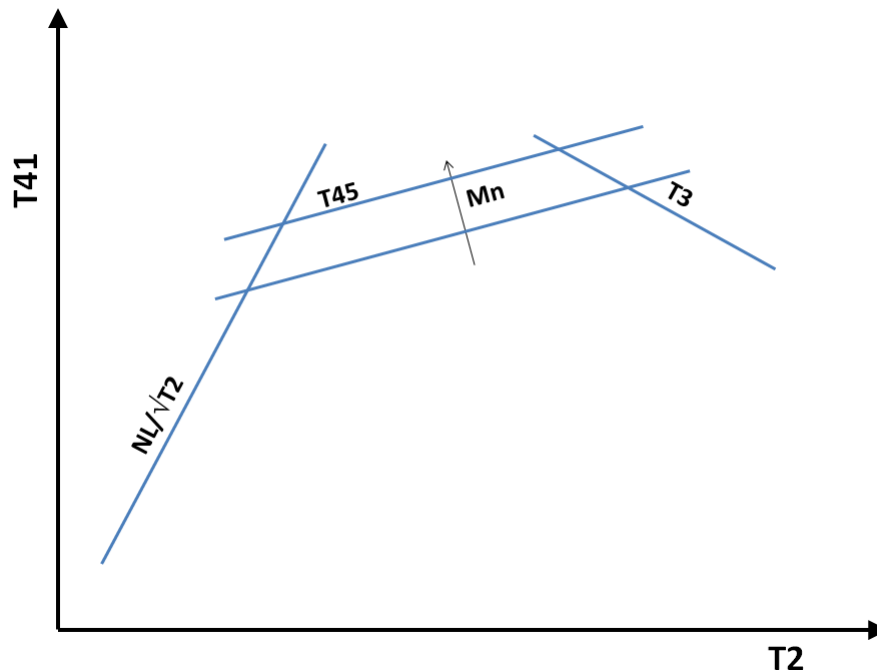

Limiters in a fighter engine control system

On a twin engine fighter aircraft the two engines deliver slightly different maximum thrust due to manufacturing tolerances and varying levels of deterioration. This is acceptable, the thrust asymmetry is not a problem for the aircraft flight control since both engines are mounted near to each other.

A side effect of striving for maximum thrust is, that there are cases where a throttle lever movement does not modulate thrust. Think of the situation when the throttle lever angle for maximum thrust corresponds to 100% N_L . In case of an aged, deteriorated engine, it might happen that $N_L=100\%$ cannot be reached because the temperature limiter prevents achieving spool speeds above 97%, for example. In such a case, when the throttle lever is moved from the 97% N_L position to the max thrust position (demanding 100% N_L), nothing will happen. The magnitude of this "dead band" in the throttle lever angle - thrust relationship depends on the flight condition and the level of engine deterioration.

4.10.3.2 Subsonic Airliners

On subsonic transport aircraft (commercial airliners) it is desirable to get for a given throttle lever angle always the same thrust, independent from the general quality and the age of the engine. The high thrust potential of a new engine is not fully used, the maximum thrust available to the pilot is implicitly defined by the thrust of the aged, deteriorated engine running at its temperature limit. This use of the engines has several advantages:

1. There is never a thrust difference between the engines on the right and the left wing of the aircraft. This avoids trimming drag which would exist when the engines on both wings would deliver different thrust.
2. The engine life is extended because new engines run at lower hot end temperatures compared to **fully rated** engines.
3. The problem with the dead band in the throttle lever angle (TLA) - thrust relationship as described in the previous section can be avoided.

For thrust management a schedule of a single **thrust setting parameter** is defined in such a way that the engine operates under all circumstances within the certified limits.

4.10.3.2.1 Flat Rating at Sea Level

The thrust of a jet engine within the take off flight envelope depends primarily on the inlet total temperature T_2 and secondarily on flight Mach number. For explaining the so-called *Flat Rating* we consider the situation at constant flight Mach number, thus T_2 is directly proportional to the outer air temperature OAT (the ambient temperature).

A jet engine could generate, at a constant burner exit temperature, on a cold day much more thrust than on an ISA or a hot day. However, designing an aircraft for the full thermodynamic cold day sea level take off thrust would result - due to the enormous mechanical loads - in a heavy aircraft structure. Therefore it is common practice to limit the sea level take off thrust when the ambient temperature is lower than the so-called "**Flat Rate**", "**Kink Point**" or "**Corner Point**" temperature which is usually 30°C - at sea level this is equal to $\text{ISA}+15^\circ\text{C}$.

While OAT is at or below the kink point temperature, the thrust is limited to protect the aircraft structure. In this ambient temperature range ($\text{OAT} < \text{OAT}_{\text{kink point}}$) the turbine inlet temperature T_{41} increases with OAT. If the ambient temperature is higher than the kink point temperature, then the turbine inlet temperature is kept constant (at the kink point value) to protect the engine. Thrust decreases with increasing OAT.

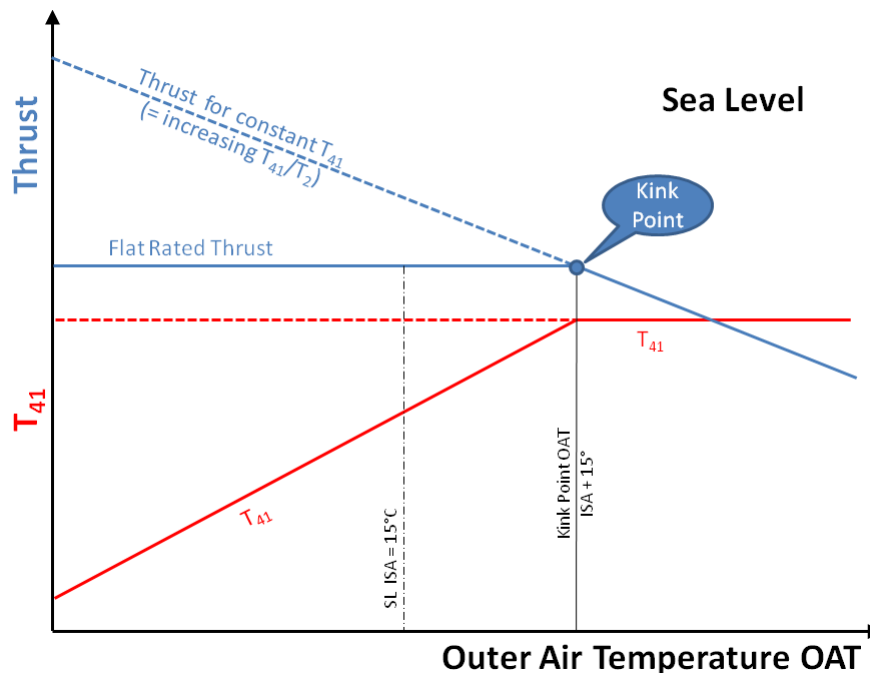

Flat Rating at Sea Level, constant Mach number

4.10.3.2.2 Flat Rating at Altitude

Between sea level and 11km altitude the ISA ambient temperature decreases with a rate of $-6.5^\circ\text{C}/1000\text{m}$. Also the **hot day temperature** decreases with altitude and therefore keeping the kink point temperature constant (at the sea level value of 30°C) would not make sense. Therefore the kink point temperature is calculated as $\text{ISA}+15^\circ\text{C}$ for all altitudes.



Let us assume again that the flight Mach number is constant, thus $T_2 = \text{const} \cdot \text{OAT}$. At the kink point the turbine inlet temperature T_{41} is at its maximum. Since at altitude the kink point OAT respectively T_2 is lower than at sea level, the ratio of $(T_{41}/T_2)_{\text{kink point}}$ raises with altitude.

T_{41}/T_2 is a non-dimensional parameter which is connected with all the other non-dimensional engine performance parameters. Thus rising T_{41}/T_2 values go along with higher corrected flow and corrected spool speed $N/\sqrt{\Theta}$, compressor pressure ratio and also non-dimensional thrust F_N/δ , for example.

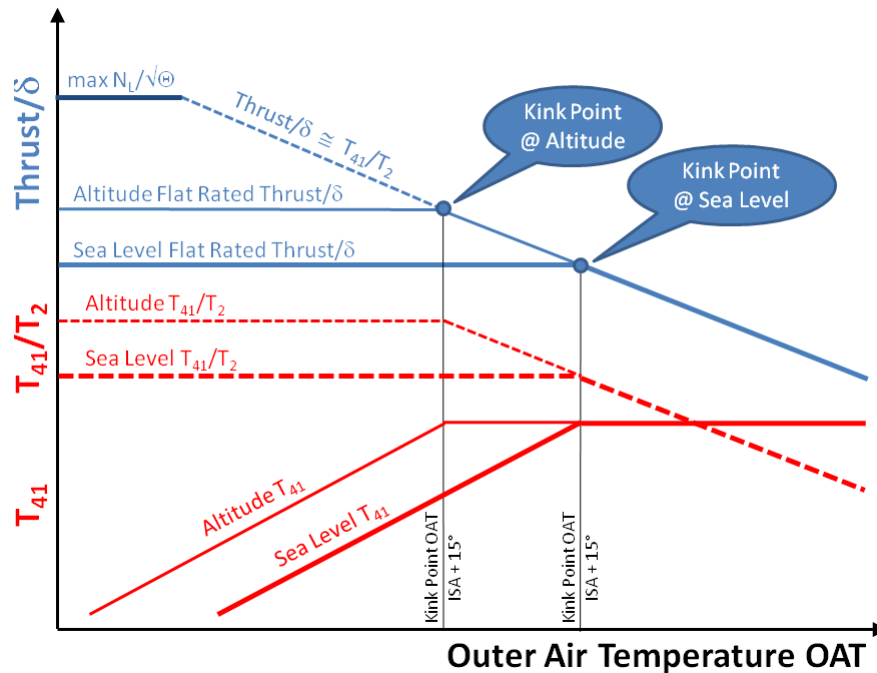

Flat rating at altitude

At high altitude it may happen that T_{41}/T_2 can be no longer increased because a corrected spool speed limit prevents that. In such a case corrected thrust F_N/δ remains constant and does not raise further with altitude.

Note that in spite of high corrected thrust at altitude, the true thrust will be lower than at sea level.

4.10.3.2.3 EGT Margin

A deteriorated engine needs a higher burner exit temperature for achieving the rated thrust compared to a new engine. Thus the exhaust gas temperature (EGT) can be considered as an engine quality indicator. The exhaust gas temperature (EGT) margin is the difference between the maximum permissible EGT (the red line temperature) and the EGT observed on an engine running at Take Off with a temperature greater than the kink point temperature.

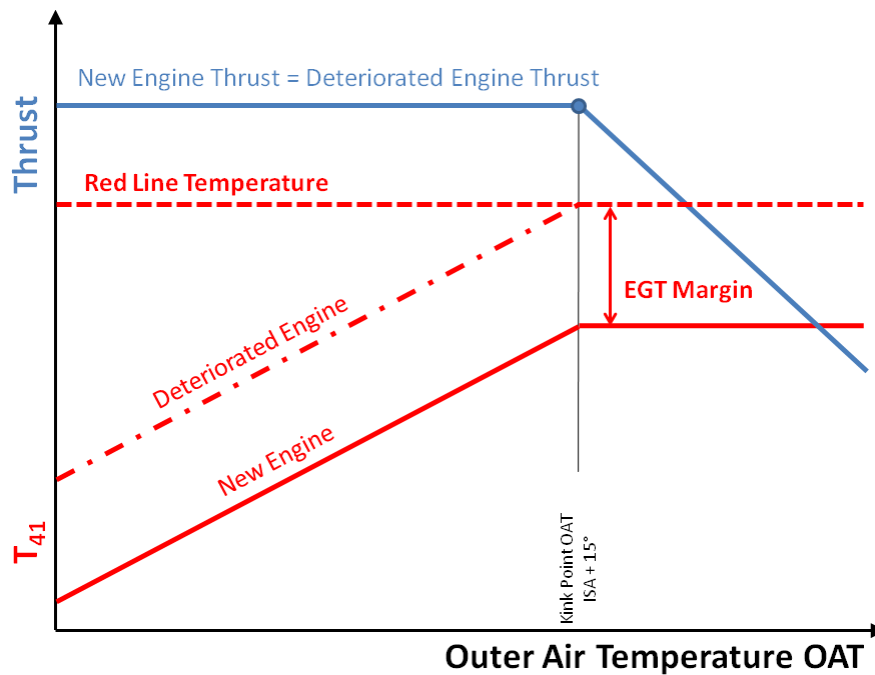

Exhaust Gas Temperature (EGT) Margin

A new engine has typically an EGT margin of 100°C.

4.10.3.2.4 Thrust Setting Parameters

Engine thrust cannot be measured directly on the aircraft, therefore some other measurable parameter(s) must be controlled in such a way that the desired thrust is achieved.

General Electric and CFMI use fan speed N_L , expressed as percentage, as the primary thrust setting parameter. N_L is easy to measure and the signal is very reliable. The disadvantage of using N_L is that engine deterioration affects the proportionality of speed and thrust. Fan deterioration (fouling, increased tip clearance) reduces mass flow (and thus thrust) at a given speed while core deterioration increases the core nozzle total temperature and thus core thrust.

Engine Pressure Ratio (EPR) is the primary thrust setting parameter on Pratt&Whitney and Rolls Royce engines. EPR is a more direct measure of thrust than N_L because engine deterioration does not affect the correlation between EPR and thrust. This can be seen from the thrust formula for static conditions in which P_8/P_{amb} is the engine pressure ratio:

$$F = A_8 \cdot P_{amb} \cdot \frac{2\gamma}{\gamma - 1} \left[\left(\frac{P_8}{P_{amb}} \right)^{\frac{\lambda - 1}{\gamma}} - 1 \right]$$

However, EPR is more difficult to measure because two (sometimes even three) highly accurate pressure signals are required. Icing of pressure probes is a risk. N_L is used as a backup control mode in EPR controlled engines.

Engine pressure ratio can be defined in various ways. Pratt&Whitney uses *Core EPR*, Rolls Royce *Integrated Engine Pressure Ratio (IEPR)* which is a weighted mean of bypass exit and core exit total pressure related to total pressure at the engine face.

In the *Off-Design Input* window you can select between various definitions of engine pressure ratio. Which definitions are available depends on the engine configuration.



4.10.3.2.5 The Throttle Lever

On the Airbus A319/A320/A321, for example, thrust is set by the pilot with a throttle lever which has the following stops:

- *Take Off*, Go Around
- Max Continuous
- Max Climb
- Idle
- Reverse

On other engines respectively aircraft this device is also called power lever. The command values are called TLA (*Throttle Lever Angle*) or PLA (*Power Lever Angle*)

The throttle lever can be positioned manually at designated stops and also anywhere between *Idle* and *Max Climb*. In auto-throttle mode the thrust is varied between *Idle* and *Max Climb* thrust. Between the *Idle* and *Max Climb* there is a linear relationship between the throttle lever position and the [thrust setting parameter](#),

Take Off rating is the maximum thrust certified for take off. It is time limited to five minutes with all engines operating and ten minutes with one engine inoperative.

Go-Around rating (not part of the GasTurb 13 control system) is similar to *Take Off* rating and also limited to five minutes. The thrust setting parameter values (N_L respectively EPR values) are different because of the effect of the higher flight Mach number during Go-Around. This rating is intended for a missed approach.

The *Maximum Continuous* rating is the maximum thrust certified for continuous use. To prolong engine life, this rating should not be used under normal operating conditions to increase aircraft speed or rate of climb. This rating should be used at the pilot's discretion and is intended for use in an engine out situation and will allow the airplane to continue operating, but at a lower altitude and fly to an alternate airfield, if necessary.

The *Maximum Climb* rating is the maximum thrust approved for normal climb operation. It is not a certified rating.

Sometimes there is also a *Max Cruise* rating which is lower than the *Max Climb* rating.

Setting the throttle lever to the *Idle* position will yield - depending on a signal from the aircraft - either Low Idle (Ground Idle) or Flight Idle (Approach Idle) thrust.

If the throttle lever is set between the *Max Continuous* and *Max Climb* stops or between the *Take Off* and *Max Continuous* stops, the upper TLA will determine the thrust.

4.10.3.2.6 Rating Availability in the Flight Envelope

The *Take Off* rating is available only at low Mach numbers and altitudes. The rating schedule is tabulated as [Thrust Rating Parameter](#) = $f(\text{OAT,alt})$ for a constant Mach number (typically 0.2 ... 0.25).

Max Continuous rating can be selected at all Mach numbers up to a certain altitude while the *Max Climb* ratings is available everywhere in the flight envelope.

In the rating schedules for *Max Continuous*, *Max Climb*, *Max Cruise* and *Idle* the Mach number is a parameter: **Thrust Rating Parameter** = $f(\text{OAT,alt,Mn})$

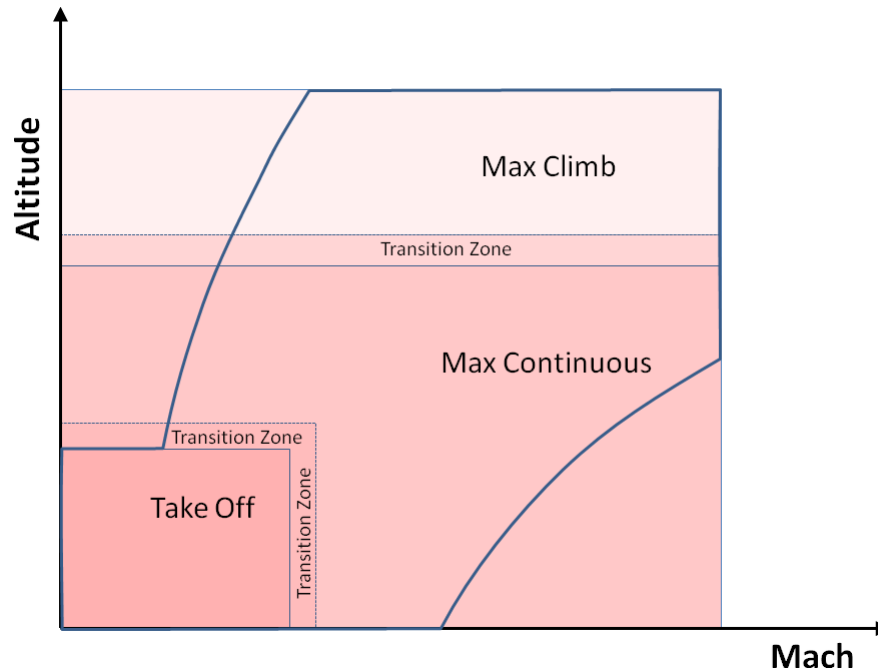

Ratings in the flight envelope

In the *Take Off* envelope, the maximum value of the thrust rating parameter is given by the *Take Off* schedule. In the *Max Continuous* envelope the thrust rating parameter is limited by the *Max Continuous* schedule value. Similarly, in the *Max Climb* envelope the upper limit for the thrust rating parameter is defined by the *Max Climb* schedule. Between the rating envelopes there are transition zones in which the maximum thrust value smoothly changes between the neighbor schedules.

4.10.3.2.7 Calculating Rating Schedules

With GasTurb 13 you can calculate rating schedules for a commercial aircraft quickly. Select  (*Power Mgt.*) in the *Controls* button group within the off-design input window. Make sure that all the maximum and minimum limiters that are relevant for your engine are switched on, however, do not use limiter schedules.

Creating rating schedules means that hundreds of off-design points with various altitudes, Mach numbers and ambient temperatures need to be calculated. For all flight conditions and ratings the operating points must be within the valid regions in all component maps. If that is not the case, then you will most probably encounter convergence problems.

Before clicking the *Power Management* button it is strongly recommended to do some single point calculations with extreme ambient conditions and maximum limiters switched on. Click the *Max Limits* button in the *Controls* button group for checking the operating conditions at rated power.

Even more important is to check the minimum limiter settings because these will define the idle schedule. The minimum limiter settings are applied while the *Min Limits* button in the *Controls* button group is activated. If you encounter convergence problems during the idle tests then check the operating points in the component maps. Employ a handling bleed schedule if the surge margin is not sufficient. Use for the minimum corrected spool speed limiter a value which is high enough to guarantee stable engine operation.

If all max and min limiters are set reasonably then convergence problems are very unlikely. If such an unlikely event happens and for an operating condition the calculation does not converge then this will be visible as a kink in the schedule. You can try to get rid of this kink by resetting the limiters



slightly and re-run the schedule creation. Alternatively you can remove this kink from the schedule by editing the schedule manually in your preferred text editor.

Note that idle schedules can look kinky even if all the off-design iterations have converged. This is due to the limited numerical accuracy. It is easy to make the idle schedule smooth by moving the inaccurate schedule points with the mouse to the desired position.

4.10.3.2.7.1 Take Off Rating

When you select *Power Management*, then the following window will open:

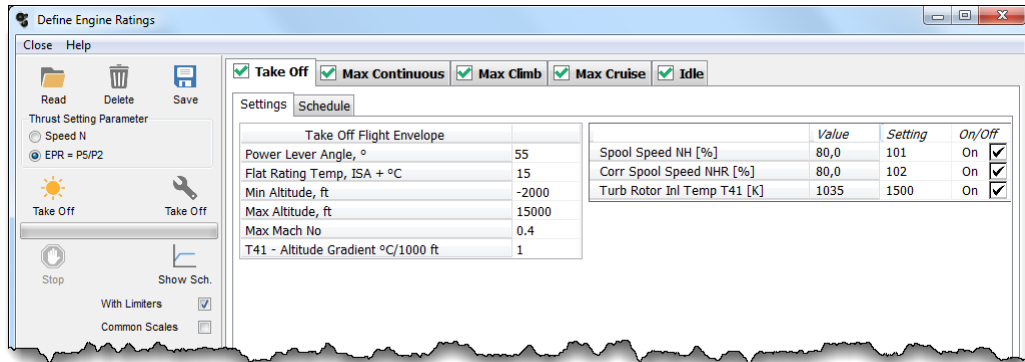

Take Off rating schedule input

The table on the right contains all the limiters that were selected in the off-design input window. Note that you can make limiters inactive by switching them off, however, you cannot add new limiters here. In case you have forgotten a limiter you need to return to the off-design input window.

The engine model usually represents an average new production engine. Such an engine produces much more thrust than a poorly manufactured and deteriorated engine. Since even the worst engine at the end of its service life has to produce the rated thrust, the T_{41} limiter for the new engine has to be set to a moderate value. To be precise: it must be set to the value which results at sea level in the rated thrust for the kink point OAT. The model of the new engine produces the rated thrust at a lower T_{41} than the design temperature level and this yields the so-called exhaust gas temperature (EGT) margin.

The table on the left contains further input data for calculating the schedule. The number for the *Power Lever Angle* can be selected arbitrarily, however, it must be consistent with the numbers chosen for the other ratings. The *Flat Rating Temperature* is the temperature difference to ISA, the International Standard Atmosphere. The meaning of the *Max Assumed Temperature* is explained in the context of de-rating.

Min. and *Max Altitude* inputs set together with the *Max Mach No.* input the boundaries of the *Take Off* flight envelope. The schedule is calculated employing a constant Mach number in the middle of the Mach number range.

The T_{41} number given in the limiter table is the value for sea level. The take off thrust lapse rate over altitude can be adjusted with the *T41 - Altitude Gradient °C/1000ft* as required.

The calculation of the *Take Off* schedule for the selected thrust setting parameter begins after clicking the *TO Schedule* button at the specified *Max Altitude*. The thrust parameter at the kink point is calculated first. For all temperatures below the kink point temperature, the engine pressure ratio is kept constant. In case spool speed schedules are created, the corrected spool speed is kept constant in that temperature range. For temperatures above the kink point temperature the full off-design calculation is performed.

Ambient temperature (OAT) is increased in steps of 5°C, starting with the kink point temperature, until it is greater than ISA+39°C. Then altitude is reduced by 1000ft and the same series of points as before is calculated.

Dependent on the selected rating parameter you get one of the following two schedule versions:

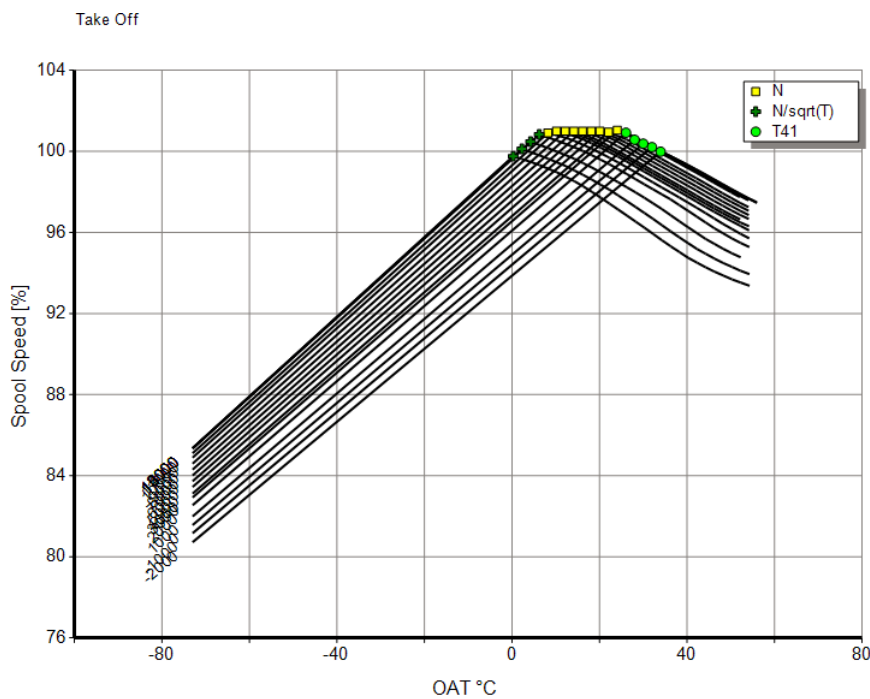
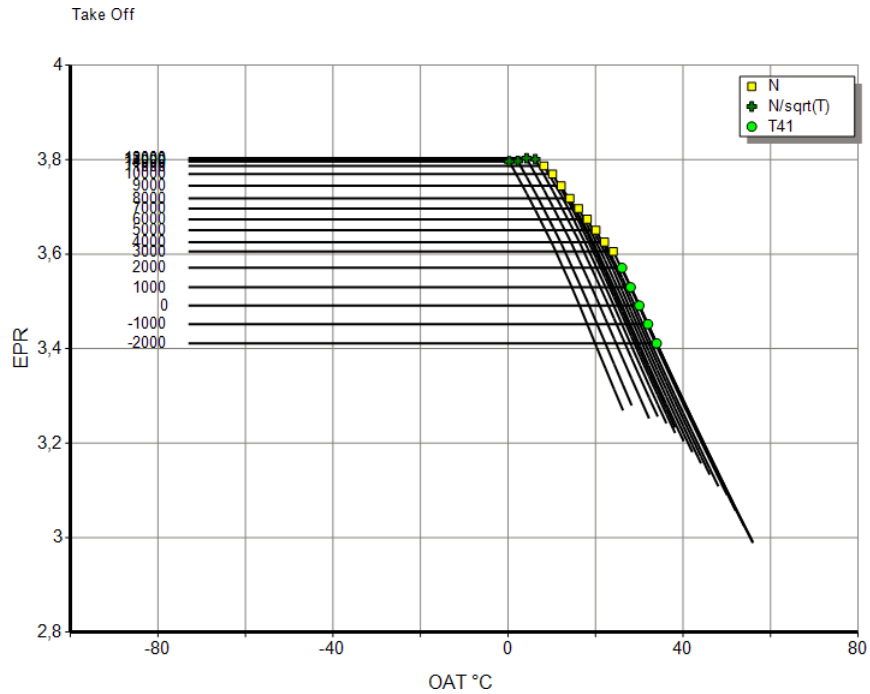

Note that there is no option to print or copy these graphics in this window. However, you can plot any of the rating schedules after performing an *Off-Design Parametric Study* with *Altitude* and *Delta T from ISA* as parameters.



4.10.3.2.7.2 Max Continuous Rating

For all ratings except the *Take Off* rating the flight Mach number is a schedule parameter.

The input for the *Max Continuous* rating calculation looks similar to that for the *Take Off* rating.

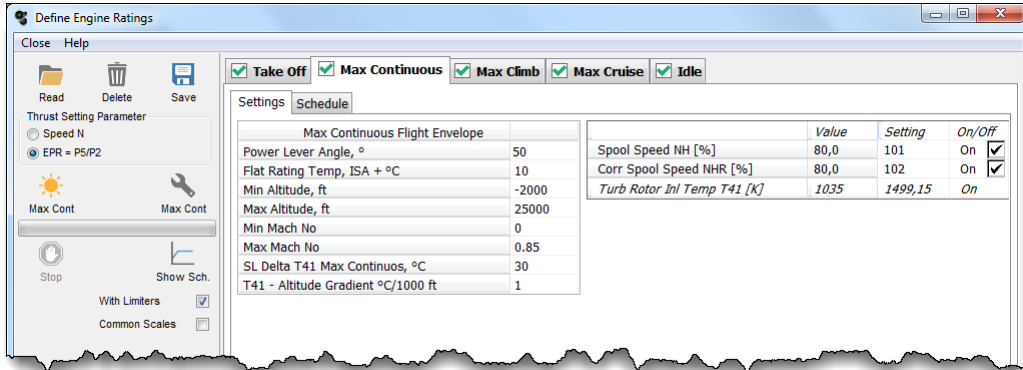

Max Continuous Rating schedule input

The main difference is that the T_{41} limiter setting is no direct input any more. T_{41} is now calculated applying a ΔT_{41} to the *Take Off* T_{41} limiter setting at sea level and the *T41 - Altitude Gradient* in $^{\circ}C/1000ft$:

$$T_{41} = (T_{41,SL,TakeOff} - \Delta T_{41,MaxCont}) \cdot \frac{\delta T_{41}}{\delta Alt} \cdot Alt$$

While the *Take Off* schedule is calculated for the mean Mach number in the *Take Off* envelope, the *Max Continuous* schedule takes the Mach number effect into account. Several tables with Mach numbers between the *Min Mach No* and the *Max Mach No* are generated.

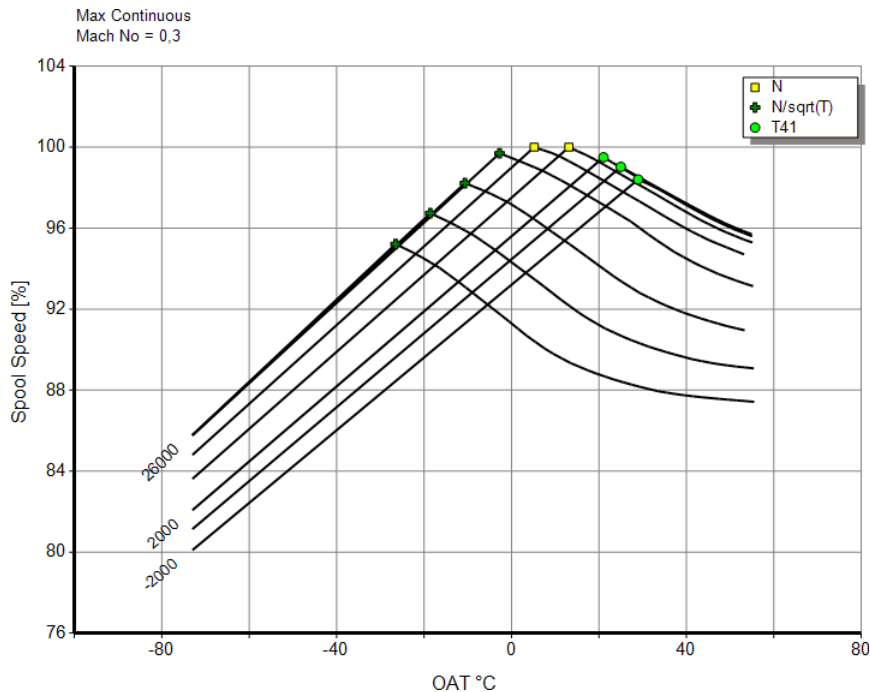

Speed Schedule for Max Continuous, Mach=0.2

4.10.3.2.7.3 Max Climb, Max Cruise

Max Climb and *Max Cruise* are ratings without time limit, they are not officially certified. *Max Climb* rating is intended for use during normal en-route climb while *Maximum Cruise* rating is the maximum thrust approved for normal cruise operation. For some engines, *Max Climb* and *Max Cruise* ratings are partially or fully identical.

The input for creating *Max Climb* and *Max Cruise* schedules is similar to that of the *Max Continuous* rating:

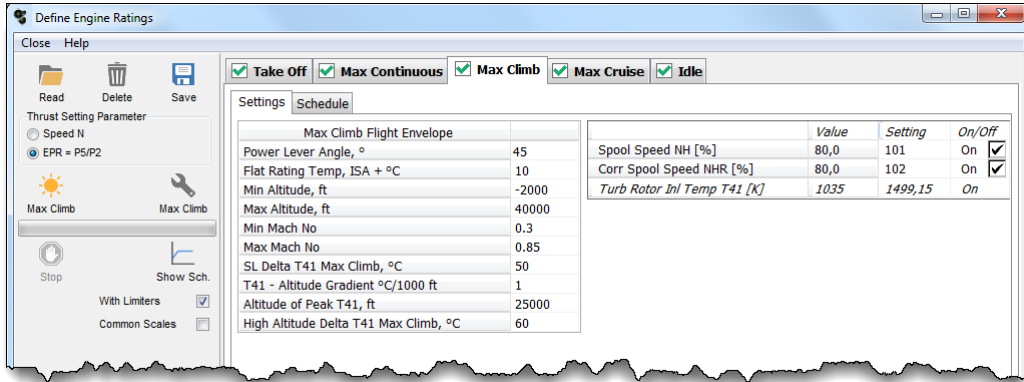

Max Climb Rating schedule input

An overview of the T_{41} limiter setting options is shown in the next figure. The *Take Off* T_{41} limit at sea level is the base point for all ratings. *Max Continuous*, *Max Climb* and *Max Cruise* T_{41} limiter settings for sea level are calculated by deducting a corresponding ΔT_{41} from the base point value. In case of *Max Climb*, for example, this ΔT_{41} is specified in the figure above as *SL Delta T41 Max Climb*, °C.

T_{41} can be made a function of altitude for all ratings by setting the *T41 - Altitude Gradient* °C/1000ft to a value other than zero. This option allows adjusting the thrust lapse rate over altitude to the need of the aircraft.

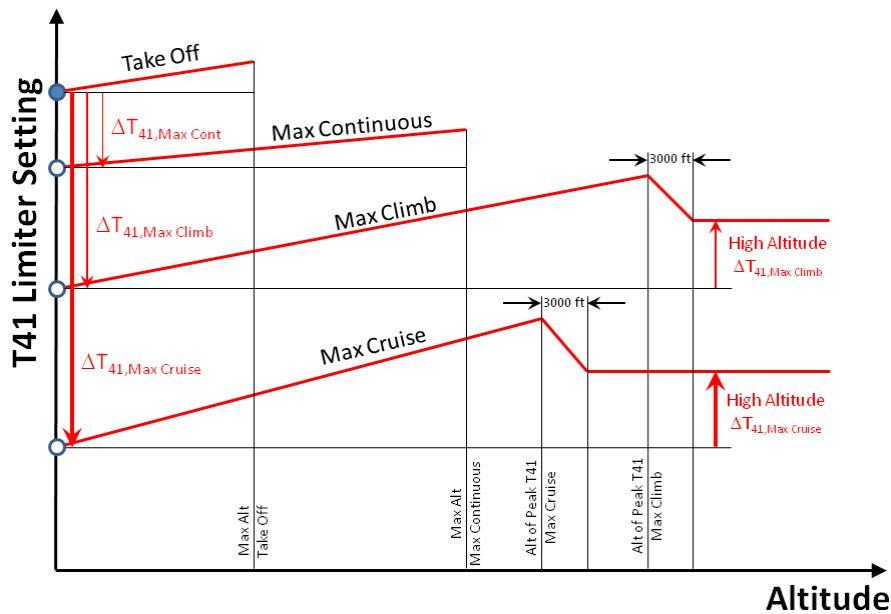

T41 Limiter settings at altitude

Max Climb and *Max Cruise* T_{41} increase with the given slope *T41 - Altitude Gradient* °C/1000ft only up to the *Altitude of Peak T41*. Above that altitude, T_{41} remains - after a transition zone of 3000ft -



constant. This value is calculated from the sea level T_{41} value of the respective rating by adding the *High Altitude Delta T41*.

Note that the engine will operate at the T_{41} limiter only at ambient temperatures higher than the *kink point temperature*. Even then, other limiters can prevent that the scheduled T_{41} is reached.

4.10.3.2.7.4 Idle

Idle thrust is obtained by positioning the throttle lever against the idle stop. Between *Idle* and *Max Climb* the thrust rating parameter varies linearly with the throttle lever position. Thus the idle schedule affects not only the idle thrust itself but also the partload thrust characteristic.

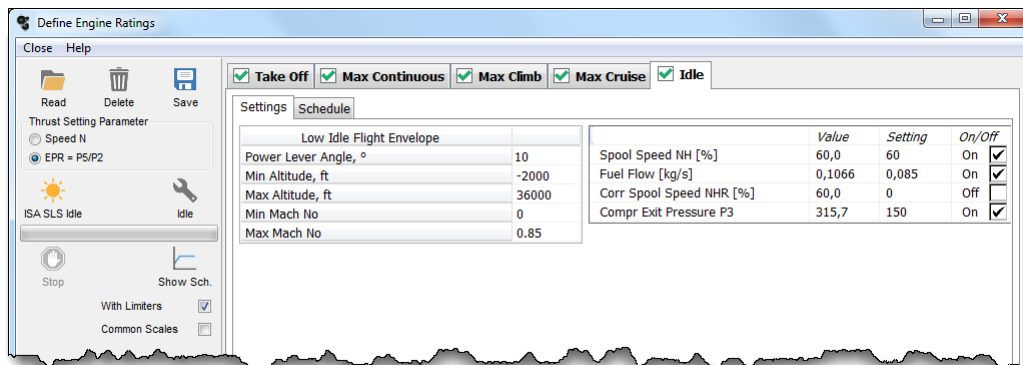

Idle Rating Schedule input

The thrust setting parameter value for idle is determined by minimum limiter settings. Note that the *Max Climb* limiters will override the *Idle* limiters. If that happens, then there will be no thrust difference between *Idle* and *Max Climb* which is not a good idea. The Idle thrust setting parameter value should always be noticeable below the *Max Climb* value.

From an engine point of view, the simplest definition of idle is the minimum non-dimensional condition for stable operation. However, other engine and aircraft requirements impose additional requirements.

Idle thrust should always be as low as possible to minimize fuel flow and pollutions. High ground idle thrust would lead during taxi to excessive brake wear and can be a problem on icy runways. In flight, high idle thrust yields a low descent rate of the aircraft. Since an aircraft is most efficient at cruise conditions, the distance covered at descent should be minimized by using the steepest possible descent angle.

However, the high pressure spool speed must not fall below a minimum value required by the electrical generator. In flight, when running an engine at idle, the bleed pressure must be at or above the aircraft demand.

Another requirement is that the engine must achieve from Approach Idle the Go-Around Thrust within eight seconds.

While calculating the idle schedule it is recommended to set the maximum *number of restarts* to a value greater than zero which minimizes the probability of convergence problems. Using minimum limits for fan pressure ratio (a bit higher than one) and for the auxiliary coordinate β of the fan map (not much lower than zero) can also help to avoid numerical problems.

The idle schedule sometimes looks kinky. Instead of investing a lot of time to examine the reason of the problem you can easily correct such a schedule. Just click the *Modify* button and move the suspicious point to the right place.

4.10.3.2.8 Using the Power Lever

After calculating the rating schedules you should save them in a rating file before closing the *Define Engine Ratings* window. The name of this file name will be referenced in the engine model file which you should save also - after closing the *Define Engine Ratings* window.

The engine model file **Demo_Gmtf_EPR_Rating_Schedule.MGM** (this is for the GEARED MIXED TURBOFAN A engine configuration) references the rating schedule file **Demo_Gmtf_EPR_Schedule.RTG**. If you load this engine model file, then you can immediately use the *Power Lever Angle* for thrust management:

Property	Unit	Value	Comment
Intake Pressure Ratio		1	
No (0) or Average (1) Core dP/P		1	
Fuel Heating Value	MJ/kg	43,124	
Rel. Handling Bleed to Bypass		0	
Overboard Bleed	kg/s	0	
Rel. Overboard Bleed W_Bld/W25		0	
Recirculating Bleed W_reci/W25		0	
Power Offtake	kW	50	
ZXN given (1) or ZT4 given (2)		1	
HPC Spool Speed ZXNH		1	
Compr Delta VG Setting [deg]		0	inactive
d_HPT Efficiency / d_XN_HP		0	
d_LPT Efficiency / d_XN_LP		0	
Power Lever Angle [deg]		0	
Delta Thrust Rating Command		0	Take Off 55
Take Off Derate		0	Max Continuous 50
Max Climb Derate		0	Max Climb 45
Assumed Temperature [deg C]		0	Max Cruise 40
Delta Idle Command		0	Partload 40...10
			Idle 10
			Not Used 0

While the *Power Lever Angle* is zero, the program works as usual. As soon as the *Power Lever Angle* is set to a value greater than zero (somewhere between the *Idle* and the *Take Off* rating angles) then all the limiters will be switched off except the one for the rating parameter. This makes sure that the rating parameter follows the scheduled value selected with the power lever. To avoid convergence problems it is recommended to set the [number of restarts](#) to a number greater than zero.

While the engine is controlled with the power lever, the five properties below the line with the *Power Lever Angle* are accessible for fine trimming the engine power:



Property	Unit	Value	Comment
Intake Pressure Ratio		1	
No (0) or Average (1) Core dP/P		1	
Fuel Heating Value	MJ/kg	43,124	
Rel. Handling Bleed to Bypass		0	
Overboard Bleed	kg/s	0	
Rel. Overboard Bleed W_Bld/W25		0	
Recirculating Bleed W_reci/W25		0	
Power Offtake	kW	50	
ZXN given (1) or ZT4 given (2)		1	
HPC Spool Speed ZXNH		1	
Compr Delta VG Setting [deg]		0	inactive
d_HPT Efficiency / d_XN_HP		0	
d_LPT Efficiency / d_XN_LP		0	
Power Lever Angle [deg]		55	
Delta Thrust Rating Command		0	Take Off 55
Take Off Derate		0	Max Continuous 50
Max Climb Derate		0	Max Climb 45
Assumed Temperature [deg C]		0	Max Cruise 40
Delta Idle Command		0	Partload 40...10
			Idle 10
			Not Used 0

4.10.3.2.9 Rating Adjustments

The basic rating tables as calculated with GasTurb 13 are valid for nominal power and bleed offtakes. In service, especially the amount of bleed air will often be different, for example when additional air is required for anti icing purposes. For considering such cases, the thrust parameter can be modified by using the generic *Delta Thrust Rating Command* input value.

On occasions when full thrust would be more than is safely required, e.g. light aircraft, long runway, headwind etc. one can choose a thrust setting below full thrust. Thrust reductions up to 25% are possible. There are two options for achieving that: **De-rating** the engine or applying the **Assumed (FLEX) Temperature** method. Both methods can be used together, e.g. a de-rated thrust can be selected and thrust further reduced by using the FLEX temperature method.

Using a thrust level which is lower than the maximum allowable lowers the engine's spool speeds, pressures and temperatures. This results in reduced stress and wear, increased engine life, and lower maintenance cost and improved reliability.

Some engines have a special rating, known as the 'Denver Bump'. This invokes a higher burner exit temperature than normal, to enable fully laden aircraft to Take Off safely from Denver, CO in the summer months. Denver airport is extremely hot in the summer and the runways are 5280ft above sea level. Simulating the 'Denver Bump' is another application of the generic *Delta Thrust Rating Command*.

4.10.3.2.9.1 De-Rating

De-rating is a shift of the thrust parameter values for all OAT's downwards. De-rating is only applied to the *Take Off* and *Max Climb* ratings.

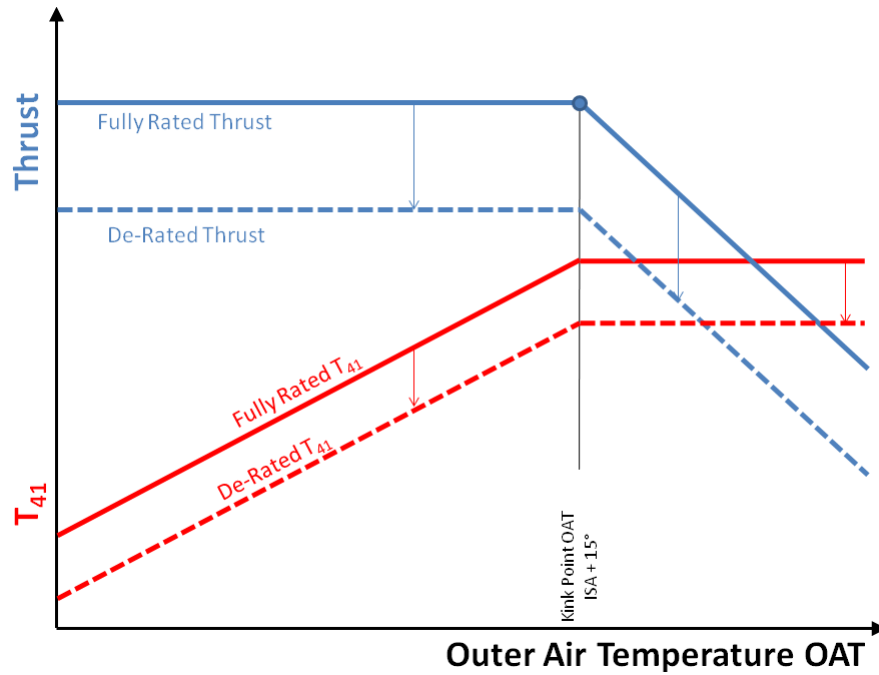

De-Rating

The *Take Off* de-rating - described with a single valued delta thrust parameter - is applied everywhere in the *Take Off* flight envelope. The *Max Climb* de-rating is applied fully up to the upper altitude limit of the *Take Off* flight envelope. Above that altitude the amount of de-rating decreases linearly with altitude up to the upper limit of the *Max Climb* flight envelope.

4.10.3.2.9.2 Assumed (FLEX) Temperature De-Rating

One method of de-rating an engine is to tell the engine that the OAT is much higher than it actually is. This higher temperature is called the assumed temperature or FLEX temperature. FLEX stands for Flexible Take Off Thrust.

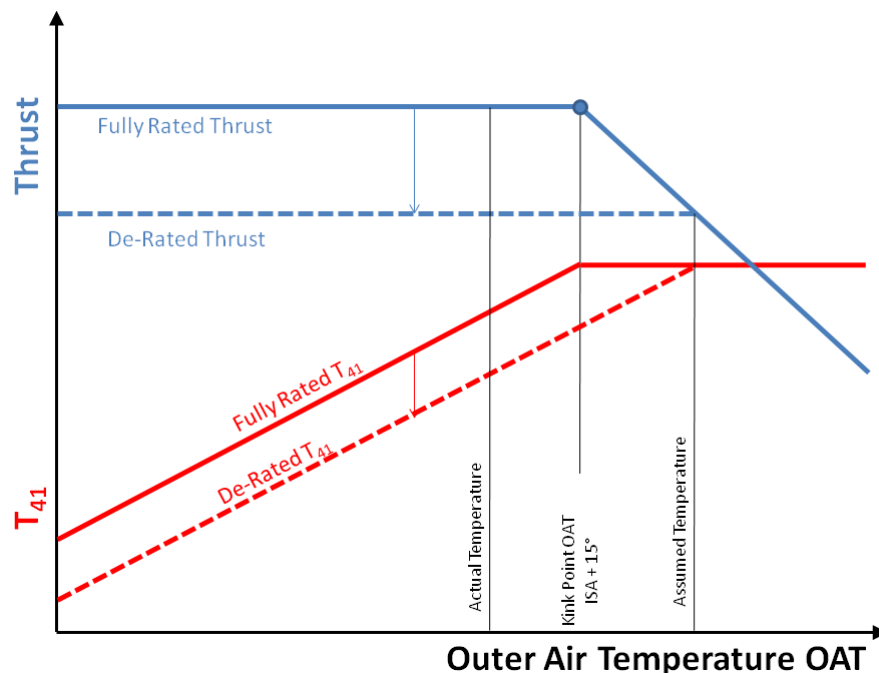



Assumed Temperature Method for De-Rating

As can be seen from the figure, *Take Off* thrust is reduced only if the assumed temperature is higher than the *Kink Point* temperature.

Max Climb thrust is not affected by differences between the actual and the assumed temperature.

4.10.3.2.9.3 Flight Idle and Ground Idle

The idle schedule generated by GasTurb 13 are for Low Idle (Ground Idle). This rating is only applicable while the aircraft is on the ground. Flight Idle (Approach Idle) is a higher thrust level because this will make the engine react faster in case of a need to go around.

Use the *Delta Idle Command* for converting the tabulated ground idle thrust parameter to the Flight Idle command. Note that both the generic [Delta Thrust Rating Command](#) and *Delta Idle Command* are applied when calculating the final thrust command.

4.10.3.2.9.4 Cruise and Partload

Partload is a thrust level between *Max Climb* and *Idle*. The partload thrust command value is proportional to the throttle lever angle which can be anywhere between the *Idle* and *Max Climb* positions.

If partload is selected, then first the thrust parameter values for *Idle* and *Max Climb* are read from the respective schedules. The actual thrust parameter command value is interpolated linearly between *Idle* and *Max Climb* correspondingly with the throttle lever position.

Note that during cruise the autopilot will adjust the thrust in the partload range only.

4.11 Transient

A complete gas turbine performance model must also allow for the calculation of the transient behavior. For such a model two things are required:

1. The thermodynamic description of the gas turbine needs to be expanded.
2. Some sort of control system to drive the model is required.

4.11.1 Simplified Model

The simplified transient model is run while the [scope Performance](#) is selected. The steady state model is modified in such a way that the power balance between compressors and turbines takes into account the power required for changing the rotor spool speed. During accelerations more turbine power is needed than for steady state operation and the opposite is true during decelerations because of the polar moment of inertia.

The power required to accelerate the spool of a turbojet, for example, is

$$PW_{acc} = \frac{\partial N}{\partial t} \cdot N_{rel} \cdot \Theta_{Spool} \cdot \left(N_{Design} \cdot \frac{\pi}{30} \right)^2$$

The spool speed N_{Design} will be calculated if [Compressor Design](#) is selected during the cycle design point calculation. Θ_{Spool} is the polar moment of inertia of the spool.

Accelerating a spool is similar to a performing a power offtake PW_X during steady state operation, with respect to the shift of the operating line in the turbomachinery maps. The effect of power offtake depends on the engine inlet conditions. From similarity in Mach numbers one can derive that $PW_{acc}/(\sqrt{\Theta_2} \cdot \delta_2)$ is the relevant parameter. Remember that in this expression Θ_2 stands for $T_2/288.15K$ and δ_2 for $P_2/101.325kPa$.

We can rewrite the above formula and get for the corrected acceleration rate:

$$\frac{\partial N / \partial t}{\delta_2} = \frac{\frac{PW_{acc}}{\sqrt{\Theta_{R,2}} \cdot \delta_2}}{\frac{N}{\sqrt{\Theta_{R,2}}} \cdot \Theta_{Spool} \cdot \left(N_{Design} \cdot \frac{\pi}{30}\right)^2}$$

The shift of the turbomachinery operating line will be the same when the corrected acceleration rate is the same.

In GasTurb 13 you can enter limits for the acceleration and deceleration rates that are corrected for engine inlet pressure. Thus you will automatically get a corresponding shift of the compressor operating line for sea level static conditions and for high altitudes. During accelerations the high-pressure compressor operating line will be above the steady state operating line and during decelerations it will be below that line.

4.11.2 Enhanced Model

When an engine is accelerated from idle to *Take Off* power, the increase in shaft rotational speed causes an increase in centrifugal force on the disks and blades. Gas temperatures increase, the blades and vanes get heated quickly and expand. Disk temperatures adapt very slowly to the new conditions, the disk diameter grows during short events primarily due to the centrifugal forces. The casing thermal expansion accommodates the growth of the disks and blades during the acceleration, however, the casing diameter grows slower than the blade tip diameter and consequently tip clearance reduces. After *Take Off* spool speed is reached, the casing continues to expand until equilibrium with the gas temperatures exists. At this point the clearance is at a maximum. Heating up heavy disks takes many minutes because they are in contact with just small amounts of disc cooling air which are only a small source of heat.

The simplified transient model of the engine is enhanced by considering tip clearance variations and heat flow into and from the engine hardware during transients. Many of the data required for modeling these two phenomena are readily available from the geometrical design of the engine, only a few additional material properties (specific heat, thermal expansion coefficient for blades, vanes and casings) are needed.

The enhanced model is run if the [scope More...](#) is selected. While in the simplified model the spool polar moment of inertia is an input quantity, it is taken from the engine geometry design results for free rotating spools. Note that the inertia of the power output spool from any turboshaft engine is not connected with the engine geometry calculation. This allows taking into account the inertia of the driven equipment (propeller, generator, helicopter drive system etc.).



4.11.2.1 Tip Clearance

Tip clearance has an effect on turbine and compressor efficiency, compressor flow capacity and on surge margin. Constant exchange rates between tip clearance (expressed as percentage of blade height) and flow capacity, efficiency and surge margin are applied for each compressor. With turbines only efficiency changes due to tip clearance variation are taken into account.

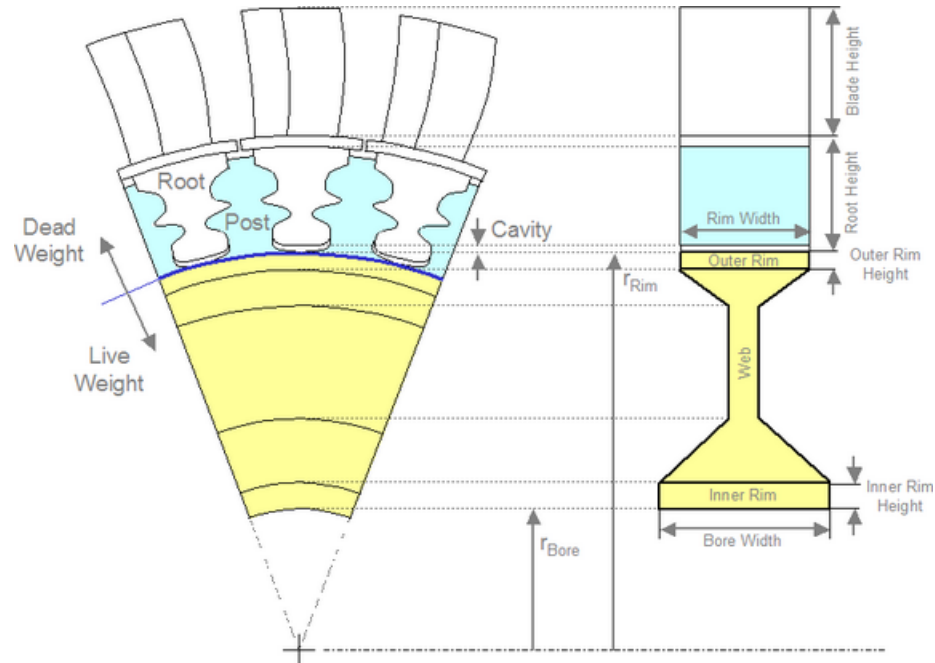

Disk geometry

Tip clearance is the difference between casing radius and the blade tip radius which is calculated from disk and platform radii and blade height. The radius of the live disk (see figure) is only affected by centrifugal forces, thermal expansion during the short transient simulation time span is ignored. Casing radius above each disk is affected by the casing temperature while platform and blade tip radii are a function of both their temperature and the centrifugal stress.

The radius of the live disk is a result of the [disk stress calculation](#); the disk temperature distribution remains the same as that found from the steady state calculation done prior to the transient simulation.

The elongation of the blade root and the airfoil due to centrifugal forces are found assuming a constant mean cross section. The thermal expansion of these two blade parts depends on the thermal expansion coefficient of the blade material and is proportional to the temperature difference between the actual temperature and that at the engine design point.

The local casing radius above the blades disk is calculated from the thermal expansion coefficient and the difference between the actual casing temperature and that at the engine design point.

For each compressor and turbine stage an absolute tip clearance, measured in percentage of the airfoil height, is found. This value is compared to that from the [reference operating line](#) which is calculated in steady state mode, i.e. for thermally stabilized conditions. The difference between the two tip clearance values is then converted to efficiency, flow and surge margin modifiers employing the exchange rates given for each component.

Before the stage performance modifiers can finally be applied to the cycle calculation, average values for each compressor respectively turbine are created. These modifiers are not immediately applied while the thermodynamic calculation has not yet converged because this would slow down the

simulation without adding much to its accuracy. Only after each time step the transient efficiency, flow and surge margin modifiers are updated.

4.11.2.2 Heat Soakage

In gas turbines there is significant heat exchange between the main gas flow, the secondary air system and the hardware. For the overall system simulation it is not necessary knowing much about local heat transfer, it is sufficient considering the heat flow in general. The - in reality - very complex engine parts are substituted by geometrically simple bits and pieces. In GasTurb 13 the engine parts in touch with the main gas flow are modeled as plates (the airfoils) and cones of constant thickness (ducts and casings).

As a further simplification it is assumed that the thermal conductivity within these parts is infinite; the temperature distribution is completely uniform.

Convective heat transfer from a gas with temperature T_{gas} to such an idealized engine part creates the heat flux Q which is proportional to the heat transfer coefficient h , the surface area A_s and the difference between the temperature of the part T (which is a function of time t) and the gas temperature T_{gas} :

$$Q = h \cdot A_s \cdot (T(t) - T_{gas})$$

This heat flux leads to a temperature change of the part with time dT/dt which is proportional to the product of the mass m of the part and its specific heat C :

$$C \cdot m \cdot \frac{dT}{dt} = -h \cdot A_s \cdot (T(t) - T_{gas})$$

The equation can be re-written with $\tau = C \cdot m / (h \cdot A_s)$ as *time constant*:

$$\frac{dT}{dt} + \frac{1}{\tau} \cdot T(t) = \frac{1}{\tau} \cdot T_{gas}$$

Integrating yields

$$\Delta T(t) = \Delta T_0 \cdot e^{-t/\tau}$$

At time $t=0$ the temperature difference between the engine part and the gas is ΔT_0 . With time $t>0$ the temperature of the part T follows the gas temperature T_{gas} with a first order lag which is fully described by the time constant τ .

For a given engine part of known material, mass and surface area, the time constant varies with the heat transfer coefficient h only. Assuming the heat transfer in the gas turbine behaves as in a pipe with turbulent flow leads to the conclusion that the heat transfer coefficient varies with Reynolds number to the power of 0.8. Absolute Reynolds numbers need not to be known, it is sufficient to know the [Reynolds Number Index](#) RNI. Knowing the time constant for one operating condition (the engine design point, for example), allows to calculate it for any other operating point:

$$\tau = \frac{\tau_{ds}}{(RNI/RNI_{ds})^{0.8}}$$



4.11.2.2.1 Compressor and Turbine

Heat flow in compressors and turbines is modeled separately for 1) airfoils, 2) blade platform including root and 3) for casings. The temperatures of the live disks are assumed to remain constant during the small time span of a GasTurb 13 simulation run. Note that the event simulated is usually much shorter than one minute.

For each of the three model element types a different time constant is employed. The magnitude of the time constant $\tau = C \cdot m / (h \cdot A_s)$ depends on the part mass m , its surface area A_s , specific heat C and the heat transfer coefficient h . The mass and the surface area of the airfoils, blade platform including root and the casing are found during engine design. Specific heat depends on the materials used and is an input quantity. Knowing the heat transfer coefficient would allow to calculate the time constant.

Remember, however, the high degree of abstraction in the heat transfer model. To be in line with reality the model needs to be calibrated in any case which could be achieved by playing with the heat transfer coefficient. It is simpler, however, to use the time constants themselves for calibrating the model. Therefore - instead of the heat transfer coefficients - the time constants are input quantities for GasTurb 13 transient simulation runs.

The values for A_s/m are results of the engine geometry design that can be of help when selecting the respective magnitude of the three time constants.

Heat transferred to or from the hardware to the gas affects the thermodynamics of compression and expansion processes. Cooling during the compression process reduces the power needed for achieving a given pressure ratio, for example.

An adiabatic compression can be described by

$$\frac{T_{2,ad}}{T_1} = \left(\frac{P_2}{P_1} \right)^{\frac{n-1}{n}}$$

This formula can be expanded to describe a compression with heat transfer:

$$\frac{T_2}{T_1} = \left(\frac{P_2}{P_1} \right)^{\frac{(n-1) \left(1 - \frac{q}{dh_{ad}} \right)}{n}}$$

In that expression q (positive if heat flows from the gas to the hardware) stands for the specific heat flow and dh_{ad} for the specific work of the adiabatic process.

The change in compression exit temperature is composed of two elements: the heat flow and a change in specific work. The latter is needed for the power balance with the turbine and can be estimated from

$$dh_c = dh_{ad} \cdot \frac{T_2 + q/c_p - T_1}{T_{2,ad} - T_1}$$

c_p stands for the mean specific heat of the gas in this equation.

On the turbine side, the heat flow is split in two parts: Half of the heat is transferred to respectively from the main stream before the expansion process, the rest of the heat downstream. This methodology is consistent with the way how turbine cooling is modeled.

4.11.2.2 Burner

Thermal effects on burners are modeled for the can only, heat exchange with the external casing is not considered. The can model is composed from sheet metal which is on both sides in contact with gas of the same temperature, the mean gas temperature in the burner $(T_4+T_3)/2$. Heat soakage is described with a single time constant, Reynolds number effects are taken into account as described above.

Heat flow from the gas into the can material reduces the burner exit temperature T_4 .

4.11.3 Transient Control

4.11.3.1 Power Lever Definition

During transient simulations you can use a power lever to control the engine power. The *Power Lever Angle PLA* is linearly correlated with the spool speed of the first compressor in case of jet engines (*NL* or *NH*, depending on the engine configuration):

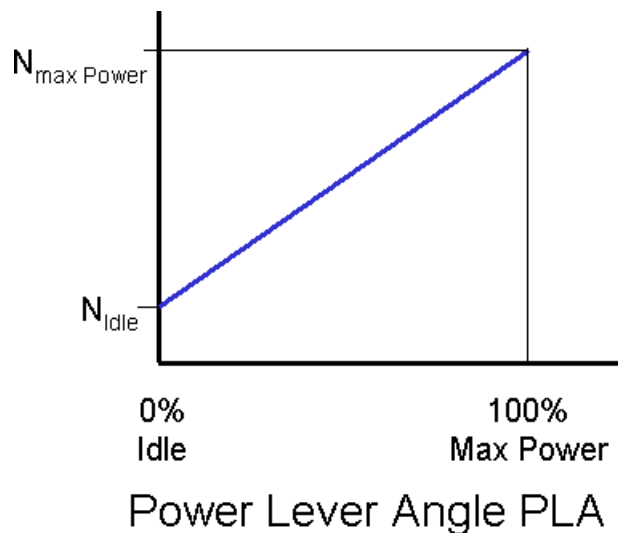

N_{idle} and $N_{max\ power}$ are input data. Input of *Pilots Lever Angle PLA=f(time)* is the default. Thus, *PLA* demands a certain spool speed which the controller tries to achieve. $PLA=0^\circ$ sets the lowest spool speed demand and $PLA=100^\circ$ sets the highest spool speed. Alternative input options are $NH=f(time)$, $NL=f(time)$ and main burner fuel flow $WF=f(time)$.

With turboshaft engines the PLA is connected with the standard day corrected shaft power.

4.11.3.2 Acceleration and Deceleration Control

The acceleration and deceleration are limited by single numbers for $(dN/dt)/(P_2/P_{std})$ of the high-pressure spool. You can also use a schedule for the corrected fuel flow W_f/P_3 to limit the excursions of the operating point in the gas generator compressor map.

4.11.3.3 Limiter Codes

The transient limiters for acceleration and deceleration control are specified on the transient input page. Additionally you can define schedules for $W_f/P_3, min$ and $W_f/P_3, max$. As with steady state simulations you can switch on several limiters. The program will satisfy all steady state and transient limiters simultaneously. Which of the limiters is active is indicated by the limiter code.

**Single Spool Engines**

1	Control	normal operation
2	N	max spool speed
3	N,corr	max corrected spool speed
4	T3	max burner inlet temperature
5	P3	max burner inlet pressure
6	T41	max stator outlet temperature (SOT)
7	T5	max turbine exit temperature
8	EPR	max engine pressure ratio
9	cp_val_max1	max composed value 1
10	cp_val_max2	max composed value 2
11	cp_val_max3	max composed value 3
12	N_dot_max	max dN/dt (acceleration)
13	far_max	max fuel-air-ratio (acceleration)
14	WF/P3 max	max WF/P3 (acceleration)
15	WF_max	max fuel flow
16	N_dot_min	min dN/dt (deceleration)
17	far_min	min fuel-air-ratio (deceleration)
18	WF/P3 min	min WF/P3 (deceleration)
19	Nmin	min spool speed
20	WF min	min fuel flow
21	NRmin	min corrected spool speed
22	P3min	min P3
23	cp_val_min1	min composed value 1
24	cp_val_min2	min composed value 2
25	cp_val_min3	min composed value 3

Engines with free power turbine

1	Control	normal operation
2	NGG	max gas generator spool speed
3	NGG,corr	max corrected gas generator spool speed
4	T3	max burner inlet temperature
5	P3	max burner inlet pressure
6	T41	max stator outlet temperature (SOT)
7	T45	max power turbine inlet temperature
8	T5	max turbine exit temperature
9	EPR	max engine pressure ratio
10	cp_val_max1	max composed value 1
11	cp_val_max2	max composed value 2
12	cp_val_max3	max composed value 3
13	NGG_dot_max	max dNGG/dt (acceleration)
14	far_max	max fuel-air-ratio (acceleration)
15	WF_max	max fuel flow
16	WF/P3 max	max WF/P3 (acceleration)

17	NGG_dot_min	min dNGG/dt (deceleration)
18	far_min	min fuel-air-ratio (deceleration)
19	WF/P3 min	min WF/P3 (deceleration)
20	Nmin	min spool speed
21	WF min	min fuel flow
22	NRmin	min corrected spool speed
23	P3min	min P3
24	cp_val_min1	min composed value 1
25	cp_val_min2	min composed value 2
26	cp_val_min3	min composed value 3

Turbofans

1	Control	normal operation
2	NH	max high-pressure spool speed
3	NH,corr	max corrected high-pressure spool speed
4	T3	max burner inlet temperature
5	P3	max burner inlet pressure
6	T41	max stator outlet temperature (SOT)
7	T45	max power turbine inlet temperature
8	T5	max turbine exit temperature
9	NL	max low-pressure spool speed
10	NL,corr	max corrected low-pressure spool speed
11	EPR	max engine pressure ratio
12	cp_val_max1	max composed value 1
13	cp_val_max2	max composed value 2
14	cp_val_max3	max composed value 3
15	NH_dot_max	max dNH/dt (acceleration)
16	far_max	max fuel-air-ratio (acceleration)
17	WF_max	max fuel flow
18	WF/P3 max	max WF/P3 (acceleration)
19	NH_dot_min	min dNH/dt (deceleration)
20	far_min	min fuel-air-ratio (deceleration)
21	WF/P3 min	min WF/P3 (deceleration)
22	NHmin	min HP spool speed
23	WF min	min fuel flow
24	NHRmin	min corrected HP spool speed
25	P3min	min P3
26	cp_val_min1	min composed value 1
27	cp_val_min2	min composed value 2
28	cp_val_min3	min composed value 3



4.11.3.4 PID Control

In a real (fixed geometry) engine the only way to influence the operating point is to modulate fuel flow. Sensors deliver signals to the control system which compares the power delivered with the power demanded and the control limiters. According to the differences between actual and demanded value the fuel flow is either increased or decreased. The very simple control system included in GasTurb 13 is of the Proportional-Integral-Differential type.

The proportional term of the speed control loop, for example, modulates the fuel flow according to

$$\Delta W_{f,P} = C_P \cdot (N_{Demand} - N)$$

while the integral term is calculated as

$$\Delta W_{f,I} = C_I \cdot \int (N_{Demand} - N) \cdot dt$$

Finally the differential term is

$$\Delta W_{f,D} = C_D \cdot \frac{d(N_{Demand} - N)}{dt}$$

You can define your control system by setting the constants C_P (*Proportional Control Constant*), C_I (*Integral Control Constant*) and C_D (*Differential Control Constant*). These constants are also called the gains of the corresponding control loops. In many cases it is sufficient to use only C_P and to set the other two constants to zero. This type of control reacts quickly but will eventually not be able to achieve the demanded value accurately.

If you use only the *Integral Control Constant*, then you can get exactly the demanded value. However, this takes some time. Often it's better to use both the *Proportional* and the *Integral Control Constant*. The *Differential Control Constant* makes the control system react very well to changes in the demanded value and can thus contribute to the stability of the control system. It should be used in combination with the other constants.

Note that the control system of GasTurb 13 can deal with many limiters simultaneously. The control loop which requires the lowest fuel flow change sets the demand. On the transient output screen you will see which [limiter](#) is active.

If you get convergence problems during transient simulations you should first try to adjust the control constants. The *Max Limiter Gain Modifier* is another tool to help with convergence problems.

Special cases are the two and three spool turboshaft engines. There you normally want to keep the low-pressure spool speed constant, while the shaft power demand varies. A typical example of such a control problem is the helicopter application. There the pilot pulls say, the collective pitch, and this increases the power requirement of the rotor. The gas generator must then react quickly in order to avoid rotor speed loss. In GasTurb 13 you specify the power requirement as a function of time, and an equivalent moment of inertia for the low-pressure spool including all elements in the drive train.

4.11.4 Input Data for Transient

For the simulation of the transient operation of a gas turbine some additional input data are needed which are described in the following sections. How to use GasTurb 13 for transient simulations has already been described in the "[Getting Started](#)" section.

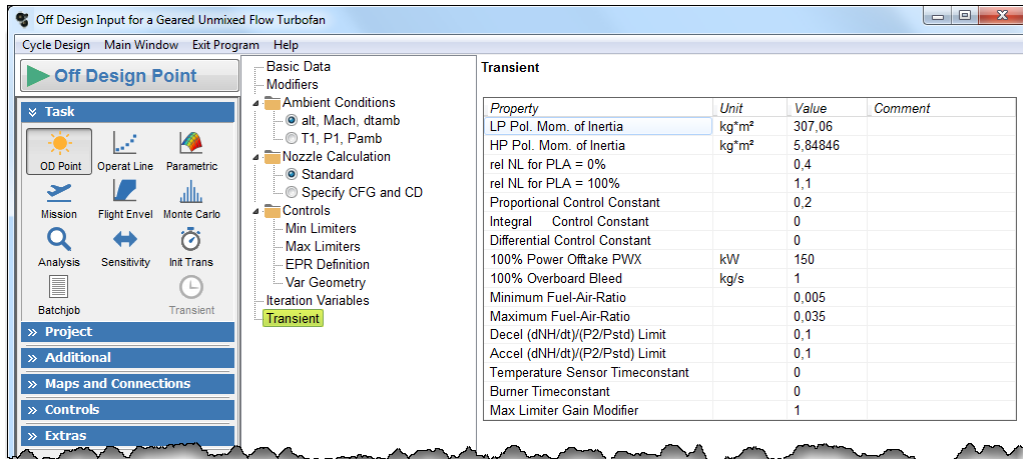

4.11.4.1 General

4.11.4.1.1 Burner Time Constant

The burning process can be modeled with a first order time lag for which you can specify a time constant. This time constant takes into account delays in heat release like movement of the fuel metering device and the time needed for evaporating the fuel.

4.11.4.1.2 Temperature Sensor Time Constant

Temperature sensors are modeled with a first order time lag for which you can specify a time constant. This time constant is valid for all of the temperature limiters you select.

4.11.4.1.3 100% Power Offtake and Bleed

If you want to simulate the effect of variations in power offtake or customer bleed then the method to enter the time dependent data is a transient control schedule in which power offtake respectively bleed is given as a percentage value. Specify the power in kW (or hp if using Imperial units) and the amount of bleed air in kg/s (lbm/s) which is equivalent to 100% on the transient data input page.



4.11.4.2 Enhanced Model

Number of Stages		3
Number of Radial Stages		0
Number of Variable Guide Vanes		1
Inlet Guide Vanes (IGV) 0/1		1
IGV Profile Thickness [%]		5
IGV Material Posit		1000
Base Sweep Angle		20
Diffusor Wall Thickness	m	0,0025
Casing Thermal Exp Coeff	E-6/K	10
Casing Specific Heat	J/(kg*K)	500
Casing Time Constant		10
Blade and Vane Time Constant		0,5
Platform Time Constant		1
Design Tip Clearance [%]		1,5
d Flow / d Tip Clear.		2
d Eff / d Tip Clear.		2
d Surge Margin / d Tip Clear.		5

At the engine design point the *Design Tip Clearance [%]* must be specified for all compressors and turbines. The same percentage of the blade height is applied to all stages of the turbomachine.

4.11.5 Time Dependent Input

4.11.5.1 Power Lever Movement

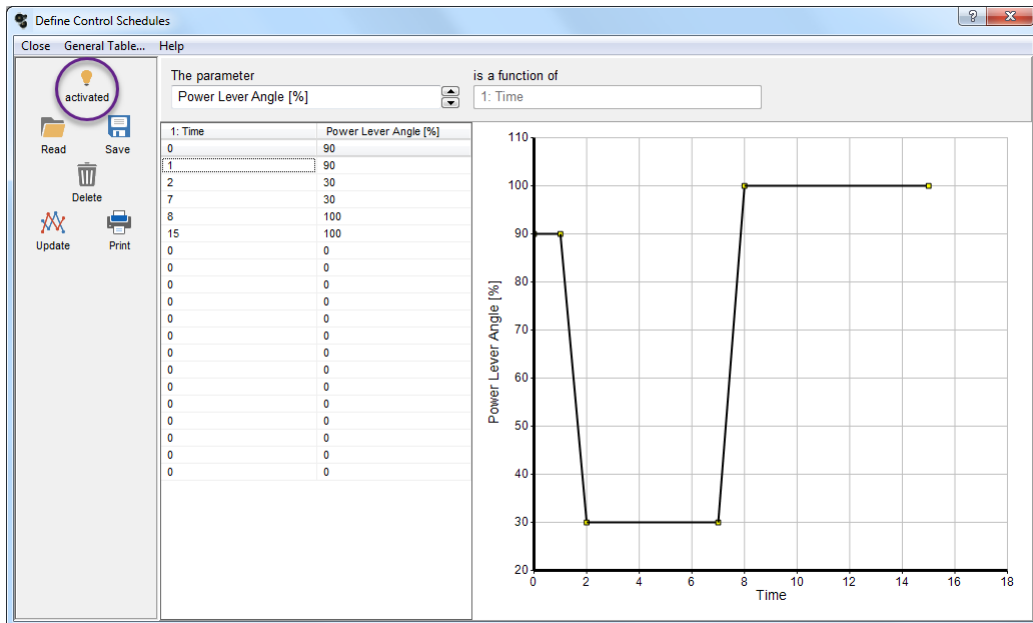

Using a slider as power lever - as in program versions prior to GasTurb 12 - is nice for demonstrating purposes, however, it is not suited for exactly repeating an exercise.

In the *Transient* window click (Time). The *Define Control Schedules* window opens, in the table the first data are already inserted: these are the time=0 and the steady state power lever angle with which the transient simulation will begin.

Enter the time values in the left column and the corresponding power lever angles in the right column of the table. Activate the table before closing the window.

In the *Transient* window you will now see this schedule as the top part of the *Overview* page. Note that you can adapt the size of this schedule picture with your mouse.

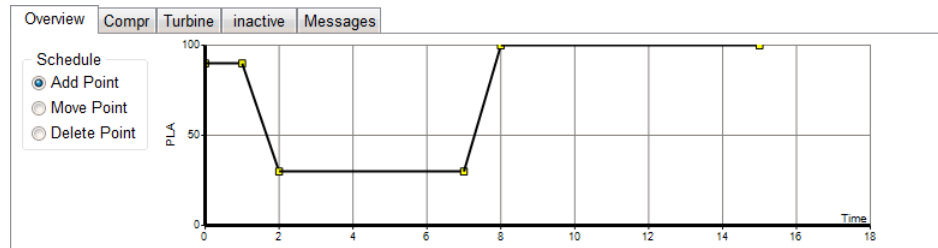

The calculation of the transient maneuver begins after a click on the top left button. The caption of this button indicates the input which will be active during the simulation.

4.11.5.2 Spool Speed

If you have actual transient test data available, and you wish to compare the GasTurb 13 results with the measured data, then you should use spool speed as a function of time as input. Click  (*Time*) and select Spool Speed [%] as parameter in the Control Schedule Input window. Enter the measured data, however, be careful with your data: if the $N=f(\text{Time})$ function implies unrealistic $\delta N/\delta t$ values then this will cause convergence problems in the simulation.

4.11.5.3 Fuel Flow

You can specify fuel flow as a function of time employing a transient input data schedule similar to the $PLA=f(\text{Time})$ input described before.

It is often very useful when designing a control system to know the transfer function of some engine parameters at different flight conditions. For that purpose calculate what happens after a step change in fuel flow  (*Fuel Step*).

4.11.6 Running a Transient

As described already in the [Getting Started](#) section you need to calculate a reference operating line before you can commence a transient simulation. In most of the plots created by the transient simulations this steady state operating line will be shown for purposes of comparison. Information from the operating line is also used for adjusting the different control loops and for evaluating transient tip clearance variations ([enhanced transient simulation](#)).

4.11.6.1 Simplified Model

The standard simplified transient calculation begins after the input of PLA, power offtake and bleed as a function of time. During the simulation the control system dictates the fuel flow and accelerates or decelerates the engine. One can observe on the screen the behavior of some important parameters like burner exit temperature, and thrust and spool speeds on the *Overview* page.

A transient calculation uses constant time steps that can be selected as 0.05, 0.1 or 0.2 seconds. The iteration variables are fuel flow, acceleration rates for the rotors, and the auxiliary coordinates of the component maps. As an example you find in the table below all the variables and the corresponding errors for a very complex engine, the geared turbofan:



variable	error
$\delta N_L / \delta t$	IPC flow error
$\delta N_H / \delta t$	HPC flow error
W_f	$W_f - W_{f,Control System}$
BPR	HPT flow error
β_{HPT}	HPT work error
β_{LPC}	LPT flow error
β_{IPC}	LPT work error
β_{HPC}	P_{δ} required
β_{LPT}	P_{18} required

After the calculation is finished, you will get a variety of graphs, including the transient operating lines in the component maps, that show all of the results as a function of time, or in any other combination. Thus it is very easy to get an insight into the basic transient behavior of gas turbine engines.

4.11.6.2 Enhanced Model

Any transient simulation begins with a steady state operating point. There is no heat flow from or to the engine hardware and the transient tip clearance corrections to efficiency, flow and surge margin are all zero.

When considering tip clearance then double accounting of the effects must be avoided. Note that for each off-design steady state operating point of an engine the actual tip clearances are different from the design value. In a standard GasTurb 13 steady state performance model this is not explicitly considered. Efficiency, flow and surge margin changes due to compressor tip clearance variation are implicitly contained in the compressor map. Carefully considered, however, this is only an approximation of reality. At a given corrected spool speed N/\sqrt{T} the actual spool speed N - and thus the centrifugal forces - vary with temperature T .

In a GasTurb 13 transient simulation, before the actual simulation run commences, a steady state operating line is calculated and stored for reference. This yields the actual tip clearance as function of spool speed N for the ambient conditions considered. During the real transient simulation again the actual tip clearances are computed, but only the differences to the reference tip clearances are converted into efficiency, flow and surge margin modifiers to the cycle calculation.

Component Modeling





5 Component Modeling

5.1 Gas Properties

5.1.1 Air and Combustion Gases

Any accurate cycle calculation program must utilize a good description of the gas properties. In GasTurb the working fluid is assumed to behave like a half-ideal gas. The gas properties specific heat, enthalpy, entropy and gas constant are a function of temperature and gas composition only, but not dependent from pressure. The temperature rise due to combustion is a function of entry temperature, fuel-air-ratio, water-air-ratio and pressure.

The gas properties and the temperature rise due to combustion are stored in tables that are created using the computer code described in [References](#) [12] and [13]. While specific heat, enthalpy, entropy and gas constant are calculated, only the combustion products H₂O and CO₂ are considered. For the calculation of the temperature rise due to combustion, however, all sorts of combustion products as well as the influence of pressure are taken into account. Thus the effects of dissociation on the temperature increase due to combustion is allowed for while the effects of CO, NO_x and unburnt hydrocarbons on the gas properties is neglected.

5.1.2 Fuel

In gas turbines mostly hydrocarbons are used as fuel. Hydrocarbons with 86.08 mass% of carbon and 13.92 mass% of hydrogen burn with air such that the molecular weight and therefore also the gas constant of the combustion products is exactly that of the dry air ($R=287.05 \text{ J/(kg K)}$). The lower heating value is 43.1 MJ/kg at $T=288\text{K}$. In GasTurb 13 this type of fuel is named *Generic Fuel*.

Kerosene, JP-4 and other fuels used in aviation and for stationary gas turbines have a composition, which comes close to that of the *Generic Fuel* as described above. However, you can also select other fuels like Diesel, natural gas or hydrogen for your cycle calculation. GasTurb 13 assumes that natural gas consists of 96% Methane and 4% Ethane. In reality there is a considerable variability in natural gas composition which can be taken into account approximately by adapting the fuel heating value. JP-10 (chemical composition C₁₀H₁₆) has been added to the list of fuels since GasTurb 10. This type of fuel has more energy per volume and less energy per mass compared to the standard fuels used in aviation.

All fuel names and the corresponding gas property file names are stored in the file FUELS.GTB. The gas property files must be in the same directory as the file FUELS.GTB. With the program GasTurb Details 6 it is easy to create further gas property files and to add their names to the list of available fuels.

The program searches for the file FUELS.GTB in the [standard data directory](#) first. If the file is not found there, it loads the default FUELS.GTB file from the program directory (where the exe file resides). Any customized version of FUELS.GTB should be stored in the data directory and the default version, which is copied to the program directory during installation, should remain untouched.

5.1.3 Humidity

Besides the data for dry air there are also data for humid air with water-air-ratios (w_{ar}) of 3% and 10% available. Note that $w_{ar}=0.03$ can mean a relative humidity well in excess of 100%.

The dominating effect of gaseous water in the working fluid is the change in the gas constant. Additionally there is a change in the isentropic exponent. While in GasTurb 13 [corrected spool](#)

speeds and corrected mass flows are calculated, only the change in the gas constant is taken into account.

5.1.4 Inlet Fogging

One of the most cost-effective ways to increase the shaft power output of a gas turbine when ambient temperature is high is to reduce the air temperature by evaporating water in the inlet air stream. Injecting water into the compressor or into the combustor are other means for increasing the power of a gas turbine.

Traditional methods of evaporative cooling of the inlet air involve amounts of water sprayed over wetted media. A more efficient way to evaporate water is using a device that creates a fog of micron sized droplets of water. These droplets can be made so small that they can achieve more evaporative efficiency than traditional evaporative coolers. By this method one can cool the air down to saturation temperature with minimal pressure losses.

For power generation gas turbines and also the two-spool mixed flow turbofan you can simulate inlet fogging during off-design simulations. In the calculation it is assumed that all the water evaporates before it enters the engine - i.e. between the thermodynamic stations 1 and 2. The relative humidity is calculated on the basis of the stagnation temperature.

In GasTurb 13 you will get the maximum amount of water that can evaporate upstream of the engine by specifying *100% Relative Humidity after Fogging*. If you enter a number greater than 100 then the water in excess of that which can evaporate will enter the first compressor as liquid water (this is called overspray) and you will get a wet compression process.

5.1.5 Water and Steam Injection

Power Enhancement and NOx Reduction

Water can be injected upstream of the engine (inlet fogging) or into the compressor (leading to wet compression). Here we talk about water injection into the combustor. Water and steam injection into the combustor are means to increase power and to reduce NO_x emissions. The amount of water respectively steam injected is described with the water-fuel-ratio wfr and the steam-fuel-ratio sfr.

It is assumed in the calculation that the injected water has a temperature of 298.15K while the steam temperature is an input quantity. If the input value for the steam temperature is lower than the evaporation temperature at burner pressure P_3 then the steam inlet temperature will be set to the evaporation temperature.

Cooling with Steam

Steam can also be used to cool the high pressure turbine of a machine designated for power generation. There are two options for such a feature: either the cooling steam is finally injected into the main gas stream or it leaves the turbine immediately after cooling some hardware. Note that *Cooling With Steam* must be selected already during the cycle design calculation.

With the first option the input quantities are

- *Cooling Steam Temperature*
- *Rel. NGV Steam Flow* ($=W_{\text{steamNGV}}/W_{\text{compressor}}$)
- *Rel. Rotor Steam Flow* ($=W_{\text{steamrotor}}/W_{\text{compressor}}$)

The nozzle guide vane (NGV) cooling steam decreases the temperature T_{41} and increases the mass flow W_{41} upstream of the first rotor. The rotor steam flow in the simulation decreases the turbine exit



temperature and increases the turbine exit mass flow. It has no effect on the work done in the high pressure turbine, however, it influences the work potential of the downstream turbine(s).

With the second option for steam cooling simulations the input quantities are:

- *Cooling Steam Inlet Temperature*
- *Rel. Vane 1 Cooling Steam Flow* ($=W_{vane1}/W_{compressor}$)
- *Rel. Vane 2 Cooling Steam Flow* ($=W_{vane2}/W_{compressor}$)
- *Rel. Temperature Drop Stage 1*
- *Vane 1 Cooling Effectiveness*
- *Vane 2 Cooling Effectiveness*

In this simulation option the cooling steam is not injected into the main gas stream. Thus there is only an effect on the main gas temperature, but no effect on the main gas mass flow. One can simulate steam cooling of single and two stage turbines. From practicality considerations the steam can only be used to cool the non-rotating vanes.

Note that with a two stage turbine which has a steam cooled second vane the work potential of the second stage is affected by the energy extracted by the cooling. This effect is not simulated and must be taken into account by adjusting the input for the turbine efficiency.

For both steam cooling options make sure to adjust your data on the *Secondary Air System* page when you switch between air and steam cooling.

5.1.6 Standard Atmosphere

Ambient pressure and temperature of a standard day are described by the International Standard Atmosphere ISA. Extreme conditions on cold respectively hot days are defined in the US Military Standard 210 (MIL 210).

Given the flight altitude both static temperature and pressure are calculated using the international standard atmosphere (ISA). Below 11 000m the ambient ISA temperature is

$$T_{amb,ISA} = 288.15K - 6.5 \cdot \frac{alt}{1000m}$$

Ambient pressure in this altitude range is

$$P_{amb} = 101.325kPa \cdot \left(1 - \frac{0.0225577 \cdot alt}{1000m}\right)^{5.25588}$$

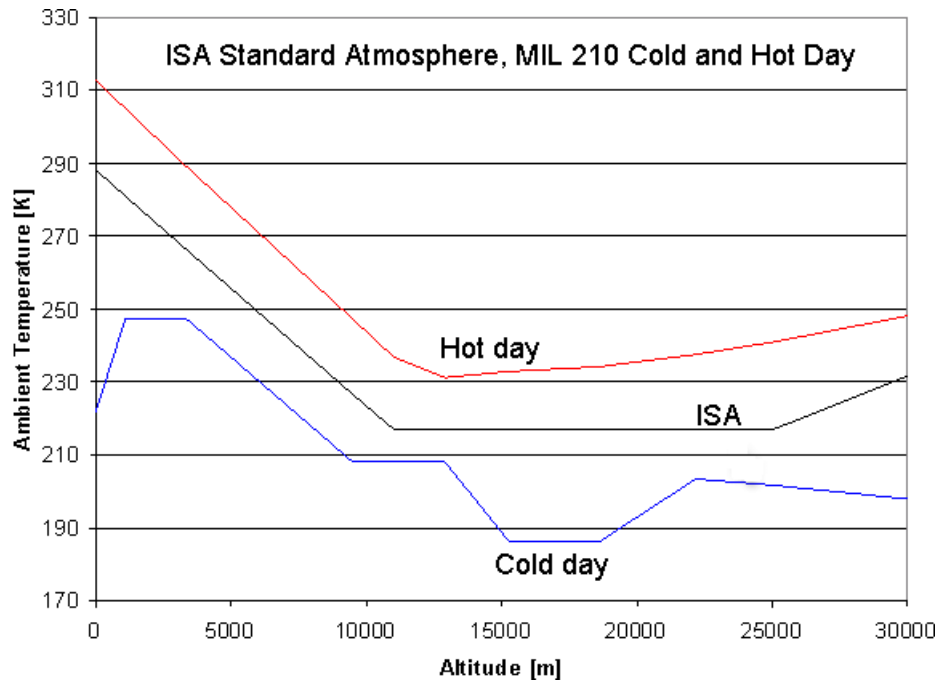

Between 11 000m and 25 000m the temperature is constant and equals 216.65K. Ambient pressure is there

$$P_{amb} = 22.632kPa \cdot e^{\frac{11000m - alt}{6341.62m}}$$

Above 25 000m the temperature increases again according to

$$T_{amb,ISA} = 216.65K + \frac{alt - 25000m}{1000m} \cdot 3K$$

and ambient pressure there is

$$P_{amb} = 2.4886kPa \cdot \left(\frac{216.15K}{T_{amb,ISA}} \right)^{11.8}$$

5.2 Component Map Format

One intake map, four compressor maps, one propeller map and two turbine maps are included with the GasTurb 13 package. You can also use your own maps. For examples of map data files look at the files delivered with the program. Note that the maps **HPC01.MAP**, **HPA01.MAP**, **IPC01.MAP**, **LPC01.MAP**, **LPC02.MAP**, **HPT01.MAP**, **IPT01.MAP** and **LPT01.MAP** must reside in the same directory as the program executable. You can store your own maps wherever you wish, in your [maps directory](#) for example.

Format of a table

All component maps consist of one or several tables. The tables consist of numbers and contain *Argument* values (A), *Parameter* values (P) and *Function* values (F).



Key	A[1]	A[2]	A[3]	A[4]	A[5]
P[1]	F[1,1]	F[1,2]	F[1,3]	F[1,4]	F[1,5]
P[2]	F[2,1]	F[2,2]	F[2,3]	F[2,4]	F[2,5]
P[3]	F[3,1]	F[3,2]	F[3,3]	F[3,4]	F[3,5]

The first number of the table is the table *Key* which is composed of the number of rows and columns of the table:

$$\text{key} = \text{number of rows} + (\text{number of columns}) / 1000$$

The number of rows is one more than the number of parameter values, and the number of columns is one more than the number of argument values in the table.

The key for the table above would be 4.006, for example. A table always starts on a new line and begins with the key. The first four argument values follow the key, separated by at least one blank. The rest of the argument values are on additional lines (five numbers per line). Only the last line of argument values may have less than five numbers.

Parameter values must always begin with a new line, and the first four function values follow on the same line. The rest of the function values are arranged as described above for the argument values.

The data need not be in specific columns, but there must be at least one blank between each number. The length of the lines must not exceed 79 columns.

5.2.1 Intake Map

An intake map consists of a single table with the relative corrected speed of the first compressor as the argument and flight Mach number as the parameter. On principle the corrected flow of the first compressor would be a better choice. However, the use of corrected speed makes the calculation simpler and does not affect the accuracy of the result very much.

The file with an intake map must begin with a single line header which commences with "99". A map title may follow after at least one blank on the same line. Have a look at the file **INTAKE01.MAP** (this file was copied to the program directory during the installation process) with your favorite ASCII editor to study an example intake map.

5.2.2 Compressor Map

The compressor map uses [auxiliary coordinates](#) called *β-lines*. These are lines of pressure ratio versus mass flow which result in unique intersections with the speed lines:

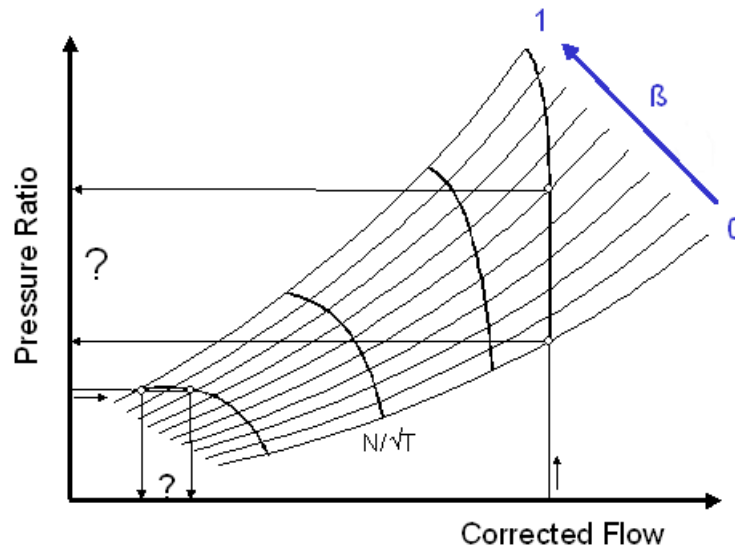

Mark the lowest β -line as $\beta=0$ and the highest β -line as $\beta=1.0$. All the other β -lines must have values between those of the limiting lines. GasTurb 13 provides up to 49 speed lines and 49 β -lines.

The program [Smooth C](#) produces β -lines that are equally spaced, and are straight lines or parabolas in the *pressure ratio, mass flow* plane. GasTurb 13 works also with other types of auxiliary coordinates. The numbers used for β , however, must be equidistant and between 0 and 1.

The detailed compressor map format is as follows: On the first line of a map data file there must be the number 99 followed by a blank. After that an arbitrary text - the map header line - may follow on the same line. On the second line the [Reynolds number correction](#) factors on efficiency are given in the following form:

Reynolds: $RNI=x1 f = y1$ $RNI = x2 f = y2$

For the [use of unscaled maps](#) the Map Reference Speed and the Map Reference Corrected Speed are needed. These values can optionally be stored with the map on a separate line after the Reynolds correction data. The keywords "MAP REFERENCE SPEED =" and "MAP REFERENCE CORR SPEED =" must be used and both values must be given in rpm. You can also enter the *Map Reference Speed* and the *Map Reference Corrected Speed* in the Special Component *Maps* window.

On the next line in the compressor map data file GasTurb expects the keyword *Mass Flow*. On the line after this keyword the table for corrected mass flow has to begin. The first number on this line is the table key derived from the number of speed lines and the number of β -lines in the map:

key = (number of speed lines + 1) + (number of β -lines + 1) / 1000

If there are 10 speed lines and 15 β -lines, for example, the table key must be 11.016. After the table key the first four β -values must follow. On the next lines follow the rest of the β -values, five numbers on each line. The last line containing β -values may have less than five numbers. Remember that the β -values must be equidistant and between 0 (first β -value) and 1.0 (last β -value).

The speed value for the first speed line begins a new line. After that the first four mass flow numbers follow. The rest of the mass flow data for the first speed line appear on the following lines. Apart from the last line there must always be five numbers on each line. The rest of the speed lines must follow in an ascending order of speed.

The keyword *Efficiency* marks the start of the second table which contains the isentropic efficiency data. The sequence and the format of the data follow the same pattern as the one described for the corrected mass flow. *Pressure Ratio* is the keyword for the third table of a compressor map.



The surge line completes a compressor map file. The keyword for this table is *Surge Line*. The surge pressure ratio is given as a function of the corrected mass flow. Note that you must store the data (up to 49 data points) in an ascending order of mass flow.

5.2.3 Reynolds Correction

Compressor and turbine maps describe the performance of turbomachinery with dimensionless parameters which represent Mach numbers. Thus the compressibility of the working fluid is taken into account. The influence of varying Reynolds number – which is the ratio of inertia and friction forces – on turbomachinery is a secondary effect. In gas turbines used for power generation Reynolds number does not play a role since the inlet pressure and temperature do not deviate very much from the standard day conditions. In the flight envelope of aircraft engines, however, the Reynolds number changes significantly.

In performance simulations it is convenient to use instead of the true Reynolds number the **Reynolds Number Index** RNI which is the ratio of the actual Reynolds number and a reference Reynolds number.

Efficiency and mass flow correction factors are defined at selected RNI breakpoints. Logarithmic interpolation yields correction factors for other RNI values.

Adequate values of the RNI breakpoints can be determined with the **pipe flow analogy**. This option is only available if the program mode "More" was selected in the program opening window.

5.2.3.1 Reynolds Number Index

The Reynolds number is defined as:

$$Re = \rho \cdot L \cdot V / \mu$$

with

ρ = density

L = characteristic length

V = velocity

μ = dynamic viscosity

The *Reynolds Number Index* RNI is the ratio of the actual Reynolds number and a reference Reynolds number for constant Mach number:

$$RNI = \frac{\rho \cdot L \cdot V}{\rho_{ref} \cdot L_{ref} \cdot V_{ref}} \cdot \frac{\mu_{ref}}{\mu}$$

L equals L_{ref} since there are no length differences between the actual and the reference conditions. Density is

$$\rho = \frac{P_s}{R \cdot T_s}$$

with

T_s = static temperature

P_s = static pressure

R = gas constant

Introduced into the formula above yields

$$RNI = \frac{P_s}{R \cdot T_s} \cdot \frac{R_{ref} \cdot T_{s,ref}}{P_{s,ref}} \cdot \frac{V}{V_{ref}} \cdot \frac{\mu_{ref}}{\mu}$$

$$RNI = \frac{P_s}{P_{s,ref}} \cdot \frac{V}{\sqrt{\gamma \cdot R \cdot T_s}} \cdot \frac{\sqrt{\gamma}}{\sqrt{R \cdot T_s}} \cdot \frac{\sqrt{\gamma_{ref} \cdot R_{ref} \cdot T_{s,ref}}}{V_{ref}} \cdot \frac{\sqrt{R_{ref} \cdot T_{s,ref}}}{\sqrt{\gamma_{ref}}} \cdot \frac{\mu_{ref}}{\mu}$$

The *Reynolds Number Index* compares conditions at the same Mach number:

$$Mn = \frac{V}{\sqrt{\gamma \cdot R \cdot T_s}} = \frac{V}{\sqrt{\gamma_{ref} \cdot R_{ref} \cdot T_{s,ref}}}$$

and this leads to

$$RNI = \frac{P_s}{P_{s,ref}} \cdot \sqrt{\frac{T_{s,ref}}{T_s}} \cdot \sqrt{\frac{R_{ref}}{R} \cdot \frac{\gamma}{\gamma_{ref}}} \cdot \frac{\mu_{ref}}{\mu}$$

Introducing total pressure P_t and total temperature T_t yields:

$$RNI = \frac{P_s / P_t}{P_{s,ref} / P_{t,ref}} \cdot \frac{P_t}{P_{t,ref}} \cdot \sqrt{\frac{T_{s,ref} / T_{t,ref}}{T_s / T_t} \cdot \frac{T_{t,ref}}{T_t}} \cdot \sqrt{\frac{R_{ref}}{R} \cdot \frac{\gamma}{\gamma_{ref}}} \cdot \frac{\mu_{ref}}{\mu}$$

The ratios of static and total pressures and temperatures are the same for actual and reference conditions since the Mach number is the same (variability of the isentropic exponent ignored). Thus the ratio of the actual and the reference Reynolds number becomes

$$RNI = \frac{P_t}{P_{t,ref}} \cdot \sqrt{\frac{R_{ref} \cdot T_{t,ref}}{R \cdot T_t}} \cdot \frac{\mu_{ref}}{\mu}$$

Reference conditions in GasTurb are $P_{t,ref}=101.325\text{kPa}$, $T_{t,ref}=288.15\text{K}$ and $R_{ref}=287\text{J}/(\text{kg}\cdot\text{K})$, thus at ISA Sea Level conditions RNI equals 1. Note that normally in GasTurb total pressure and temperature are not marked with the index t, this section is an exception.



5.2.3.2 Efficiency and Mass Flow Correction

In GasTurb 13 the Reynolds number corrections are correlated linearly with the logarithm of RNI:

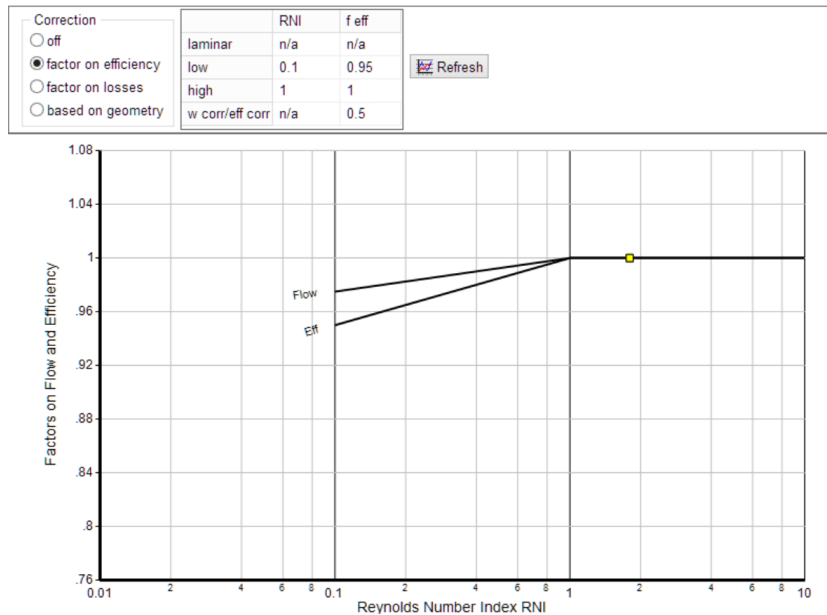

The figure shows an example for the Reynolds correction of a turbine. The RNI breakpoints are

$RNI_{low} = 0.1$	$f_{low} = 0.95$
$RNI_{high} = 1$	$f_{high} = 1$

In the left part of the figure the efficiency correction factor is interpolated linearly versus the logarithm of RNI. As RNI decreases the correlation is extrapolated, if required. For $RNI > RNI_{high}$ (turbulent boundary layer, hydraulically rough surface) the efficiency correction factor remains constant and equal to f_{high} .

A mass flow correction factor is derived from the efficiency correction factor in such a way that the mass flow correction is half of the efficiency correction in this example. If efficiency is corrected using the factor 0.96, then mass flow will be corrected with the factor 0.98.

Compressors may be affected by a steep increase of losses at very low Reynolds numbers due to the onset of laminar separation. This can be accounted for by setting $RNI_{laminar}$, which applies to compressors only.

Note that you can modify the Reynolds number correction algorithm in various ways and also switch off the Reynolds correction in the *Special Components Map* window. Modifications you make here can be stored in an [engine model file](#) (an option in the *Off-Design Input* window) and in a [map scaling file](#) (an option in the *Special Component Maps* window). When you read an engine model file then the Reynolds correction data from the engine model file will override the Reynolds correction data read from the component map file.

5.2.3.3 Pipe Flow Analogy

In an extremely simplified model, turbomachinery may be regarded as an arrangement of pipes in which the blade chord is the characteristic dimension.

The pressure losses in pipes are illustrated in the so-called Moody diagram which describes them as a function of Reynolds number and relative roughness:

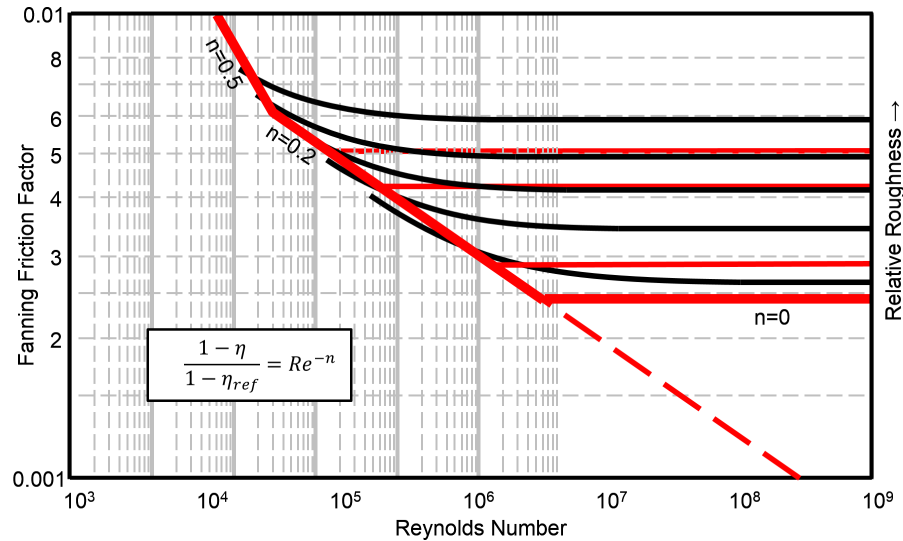

The figure shows a snippet from the Moody chart with three bold red lines added. First, the focus will be on the middle line which has a slope of $n = -0.2$. This number is also found in a popular correlation between turbomachinery efficiency and Reynolds number:

$$\frac{1 - \eta}{1 - \eta_{ref}} = \left(\frac{Re_{ref}}{Re} \right)^{-0.2}$$

There are limits for the validity of this equation.

At a given value of relative roughness there is a Reynolds number above which the losses remain constant because the boundary layer is turbulent attached and the blade surfaces are hydrodynamically rough. Due to lack of better knowledge, it is recommended to guess this Reynolds number based on the relative roughness values in the Moody chart. The horizontal line marked with $n=0$ defines for a given relative roughness the upper Reynolds number limit Re_{high} of the middle line.

The bold line on the left is much steeper than the middle line, its slope is typically $n = -0.5$. This is because below a critical Reynolds number of around $5 \cdot 10^4$ the losses in compressors increase steeply due to the onset of laminar separation.

The slopes $n = -0.2$ and $n = -0.5$ used in the pipe flow analogy are debatable numbers. A general conclusion from literature is that the value of the exponent can vary significantly from compressor to compressor. Thus it is not astonishing that Reference 1 recommends to use for the exponent n values between -0.05 and -0.25 while Reference 5 endorses the range from -0.1 to -0.14 for compressors and -0.18 for turbines.

There are several potential reasons why the numbers of the exponent n vary so much:

- The data result from tests in the transitional region of the Moody chart where the slope changes gradually from -0.2 to zero.
- The pipe flow analogy implies that all the losses are dependent on friction. This is not necessarily true. In fact, losses related to high Mach number operation and the presence of shock systems are largely insensitive to Reynolds number.
- Most authors use polytropic efficiency in correlations, some adiabatic efficiency.

Note that the steep increase of losses ($n = -0.5$) at very low Reynolds numbers is not observed in turbines. Therefore $n = -0.2$ is applicable for all turbine Reynolds numbers lower than Re_{high} .



5.2.3.3.1 Application of the Pipe Flow Analogy

Applying the pipe flow analogy is easy and needs only a single input value: the surface roughness of the blades and vanes. The Reynolds number at the cycle design point and the blade chord length are determined automatically as part of the engine geometry calculation.

The surface roughness of metallic blades is in the order of 1.5 μm . Reference 1 lists the following typical roughness values:

Precision cast surface	2 - 3 μm
Typical polished forging	0.75 - 1 μm
Highly polished	0.25 – 0.5 μm

The effective surface roughness of cooled turbine blades is certainly much higher because of the film cooling holes which interrupt the otherwise smooth surface.

Dividing the absolute roughness value by the blade chord length yields the relative roughness which is used for evaluating the Moody diagram.

Correction

off

factor on efficiency

factor on losses

based on geometry

	RNI	f (1-eff)
laminar	0.007436	2.824
low	0.01322	2.118
high	3.35	1
w corr/eff corr	n/a	0.5

Roughness*1000 [mm]

polished 0.5

normal 1.5

rough 3

very rough 6

custom 12

Blade Chord = 0.126[m]

Reynolds No = 9.790E+05

Flat Above Re = 8.013E+06

Apply 70 % ?

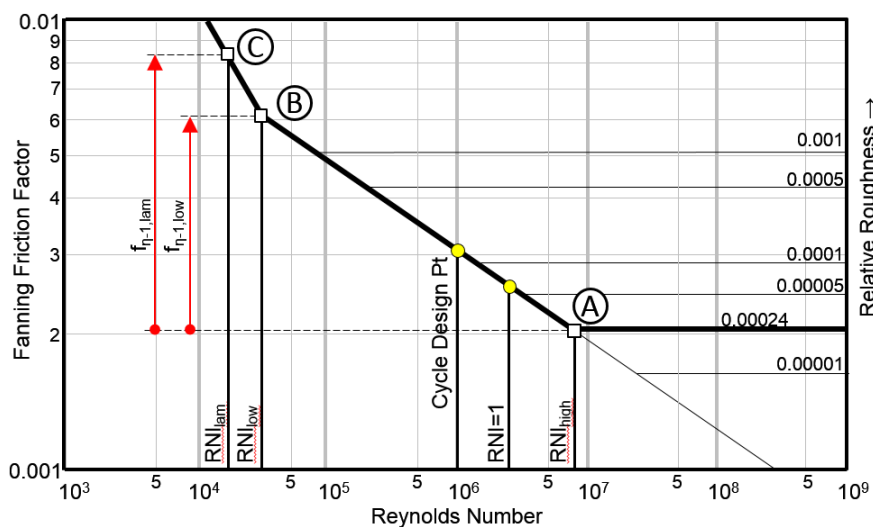

Point A in the figure is the intersection of the lines for smooth flow and the relative roughness. The Reynolds number index of point A is marked as RNI_{high} . Point B marks the critical Reynolds number $0.5 \cdot 10^5$ below which the losses in compressors steeply increase due to the onset of laminar separation. Point C is located at Reynolds number $0.25 \cdot 10^5$ and describes together with point B the slope of the laminar region (compressors only, does not exist for turbines). The Reynolds number indices for these two points are RNI_{low} and RNI_{lam} . The slopes of the smooth and the laminar regions are $n = -0.2$ respectively $n = -0.5$.

In GasTurb 13, the turbomachinery maps are scaled in such a way that no Reynolds correction is applied if RNI is greater than RNI at point A. Therefore, the loss correction factor $f_{1-\eta}$ is 1.0 if $RNI_{design} > RNI_{high}$. The efficiency correction factors at points B and C are

$$f_{1-\eta,low} = \frac{\text{loss factor@ point B}}{\text{loss factor@ point A}}$$

$$f_{1-\eta,lam} = \frac{\text{loss factor@ point C}}{\text{loss factor@ point A}}$$

During off-design calculations, the efficiency correction factor f_η is logarithmically interpolated at any RNI value. The efficiency read from the map is corrected according to

$$\eta = \eta_{map} (1 - f_{1-\eta} (1 - \eta))$$

The numbers from the pipe flow analogy can be used by clicking the *Apply* button for updating the numbers in the table.

5.2.3.3.2 Variations of the Pipe Flow Analogy

The advantage of the pipe flow analogy is that it requires only one input (the blade roughness) for creating a Reynolds correction which is certainly in the right ball park.

The exponent n in the [efficiency correlation with Reynolds number](#) can deviate from the value $n = -0.2$ which is part of the pipe flow analogy. Using numbers for n between -0.2 and -0.1 can be interpreted such that only a part of the losses are friction losses which vary with Reynolds number. If that is true then this can be taken into account in such a way that only certain percentage a of the in the pipe flow analogy losses are applied. $a = 70\%$ seems to be a reasonable value. The efficiency correction factors are then calculated as

$$f_{1-\eta,low} = 1 + \frac{a}{100} \left(\frac{\text{friction factor@ point B}}{\text{friction factor@ point A}} - 1 \right)$$

$$f_{1-\eta,lam} = 1 + \frac{a}{100} \left(\frac{\text{friction factor@ point C}}{\text{friction factor@ point A}} - 1 \right)$$

Note that the numbers for the RNI breakpoints as well as the efficiency factors and the ratio between mass flow and efficiency correction can be edited in the [table](#) as required.

5.2.4 Propeller Map

For the [propeller](#) maps also auxiliary coordinates β are employed. These [maps](#) are defined in the {power coefficient, advance ratio} plane. The map information is contained in two tables both with β being the argument and *advance ratio* being the parameter. The propeller efficiency is the function value of the first table and the *power coefficient* is the function value of the second. Instead of the Reynolds correction information there must be a blank line in the file. The β -values must be equidistant, beginning with $\beta=0$ and ending with $\beta=1.0$.

The static performance of the propeller completes the map. It is stored in the same format as a surge line and gives the ratio of thrust coefficient as a function of power coefficient. The keyword for this type of table is *Static Performance*.



5.2.5 Turbine Map

GasTurb uses for turbine maps as auxiliary coordinates β -lines, similar to those in compressor maps. They are defined in the {pressure ratio, corrected speed} plane. In two tables the pressure ratios for $\beta=0$ and $\beta=1$ are tabulated as a function of corrected speed. In two further tables, mass flow and efficiency are stored in the same way as the compressor maps, with corrected speed as parameter and β as argument. The β -values must be equidistant, beginning with $\beta=0$ and ending with $\beta=1$.

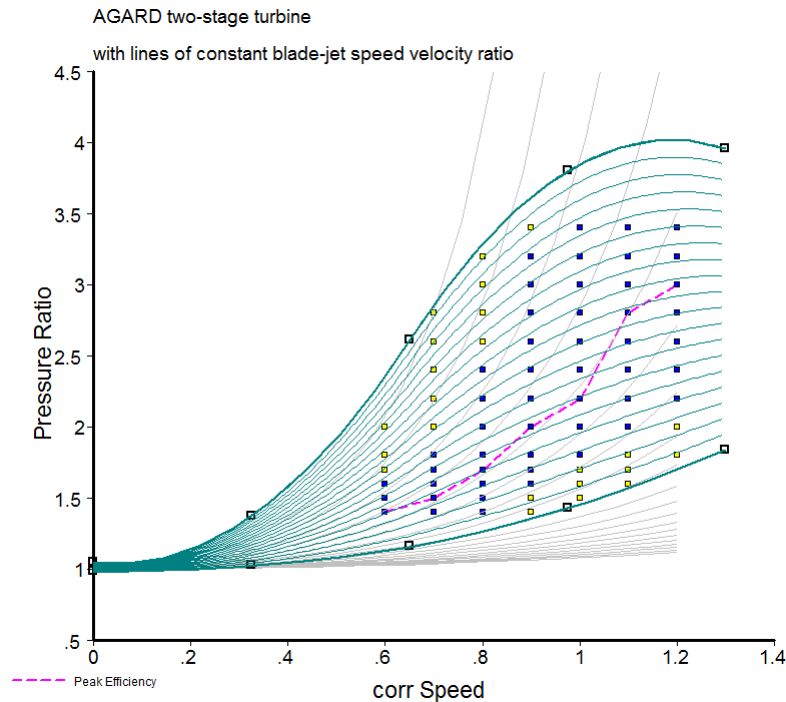

The program *Smooth T* produces β -lines that are equally spaced and composed of parabolas in the (pressure ratio, corr speed) plane as shown in the figure above.

5.2.6 Smooth C and Smooth T

The programs *Smooth C* and *Smooth T* are tools that quickly produce high quality compressor respectively turbine characteristics from measured data. Instead of genuine measured data - which are seldom available outside industry and research facilities - one can also take data from figures published in literature. Even relativized compressor and turbine map data can be used.

Both programs are also very helpful for checking maps with respect to consistency and agreement with the laws of physics.

Smooth C is suited not only for normal compressor characteristics but also for special fan characteristics that are needed for turbofan simulations. Pressure ratio and efficiency of these fans are different for the inner (core) and outer (bypass) stream. You can get both map preparation programs from the distributor from which you have got GasTurb 13.

5.3 Intake

5.3.1 Flight, Test Bed and Power Generation Input Mode

The alternatives for describing the ambient conditions of the gas turbine are:

Flight Input Mode

The given values are altitude, flight Mach number and deviation from [ISA temperature](#) as well as humidity. These values allow to calculate P_{amb} , P_1 , $T_2=T_1$ and the flight velocity V_0 .

Testbed Input Mode

Here the given values are P_1 , T_1 , P_{amb} and humidity. From P_{amb} the altitude is derived. T_{amb} is found from T_1 and P_1/P_{amb} . The flight velocity V_0 can be calculated from $V_0^2/2=h(T_1) - h(T_{amb})$ with h =enthalpy. The flight Mach number is equal to $V_0/\sqrt{\gamma \cdot R \cdot T_{amb}}$.

This input mode was called Ground Input Mode in previous versions of GasTurb.

Power Generation Input Mode

This mode is only offered for engine configurations that are suited for power generation. Input are ambient pressure P_{s0} and temperature T_{s0} , relative humidity of the ambient air and the relative pressure losses in the [inlet housing and exhaust ducts](#) downstream of the gas turbine.

5.3.2 Pressure Loss

The intake pressure ratio can be specified in several ways. Any positive number is directly used as P_2/P_1 with the exception of the value 2.0 which selects the [intake map](#) option.

Negative P_2/P_1 values are corrected for shock losses (supersonic flight only) according to MIL-E-5007:

$$\frac{P_2}{P_1} = - \left(\frac{P_2}{P_1} \right)_{input} \cdot \left[1 - 0.075 \cdot (M - 1)^{1.35} \right]$$

This equation is valid up to Mach 5, above that Mach number the intake pressure recovery is

$$\frac{P_2}{P_1} = - \left(\frac{P_2}{P_1} \right)_{input} \cdot \frac{800}{M^4 + 935}$$

For turbofan engines you can model a radial pressure profile at the engine face with the input property *No (0) or Average (1) Core dP/P*. Entering 0 for this property yields zero pressure loss in the core stream and such a pressure loss in the bypass stream that the mass averaged pressure loss equals the input value for P_2/P_1 . The default value for this property is 1.0 which implies the same pressure loss in both the core and the bypass stream. Note that you can apply any number between 0 and 1 for describing the radial pressure loss distribution upstream of the engine.



5.3.3 Altitude Test Facility

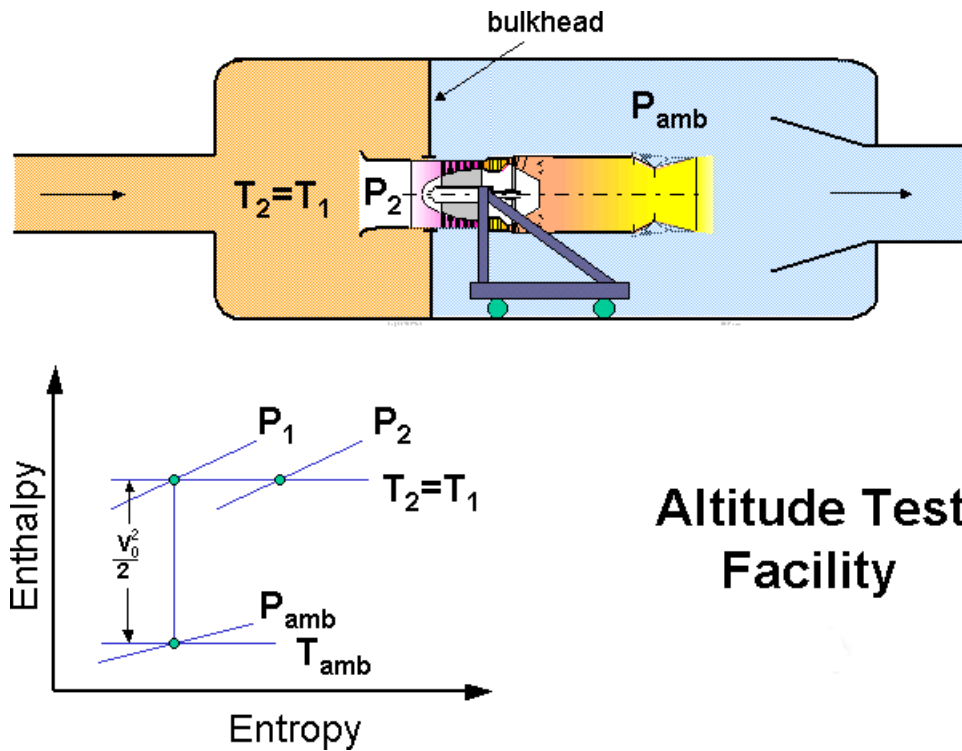

Altitude Test Facility

In an altitude test facility the following quantities are adjusted in such a way that the engine inlet conditions and the static pressure downstream of the engine are the same as in the aircraft:

- P_2 Total pressure at engine inlet
- $T_2 = T_1$ Total temperature at engine inlet
- P_{amb} Ambient pressure

During test analysis from P_2 and the aircraft intake pressure ratio P_2/P_1 the total pressure P_1 is calculated. From the static pressure P_{amb} the flight altitude is derived. Ambient temperature T_{amb} follows from the total temperature T_1 and the pressure ratio P_1/P_{amb} . Knowing T_1 and T_{amb} allows to calculate the flight velocity V_0 and the flight Mach number.

Note that for test analysis the intake pressure ratio P_2/P_1 must be a simple input quantity, it cannot be read from the intake map because any error in the intake map would propagate to the calculated flight Mach number, the flight velocity and finally to net thrust.



5.3.4 Inlet and Exhaust Pressure Losses for Power Generation

This figure shows a typical gas turbine installation as used for power generation:

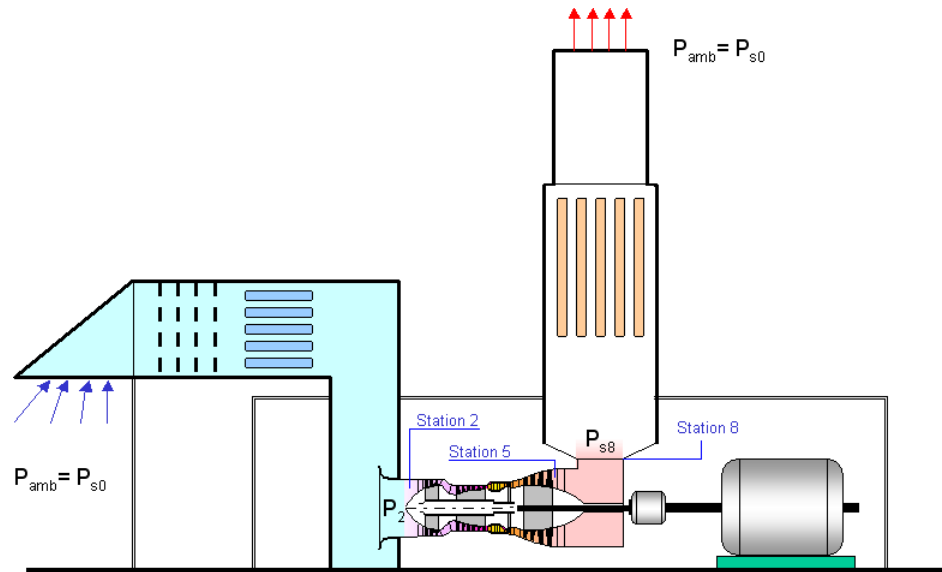

The air enters the inlet house below a rainhood, passes through filters and silencers and finally enters the gas turbine at the thermodynamic station 2. On the exhaust side there are two sources of pressure losses:

- from station 5 (by definition exit of the last turbine) to station 8 (the end of the gas turbine)
- from downstream of station 8 to ambient.

The first source of exhaust pressure losses is internal of the gas turbine, the second is external.

During cycle design both the pressure ratios P_8/P_5 and P_8/P_{amb} are input quantities. From this information the power turbine pressure ratio is calculated as a total-total pressure ratio. The power turbine should be designed together with the exhaust duct (which will be a diffuser) in such a way that the maximum shaft power is gained for a given total-static pressure ratio and the geometry restrictions that apply.

The inlet and exhaust pressure losses are valid for the corrected flow at the cycle reference point, at off-design conditions they vary with the corrected flow squared. Therefore you will find the pressure losses you have input also in the output only if you are in cycle design mode. In off-design cases, the numbers in the output will differ from those you have given as input during cycle design.

5.4 Compressor

5.4.1 Compressor Design

The term *Compressor Design* in this program is used for some simple calculations (in contrast to the more detailed [Compressor Aerodynamic Design](#)): to find compressor inlet dimensions and the rotational speed. Those quantities are needed for [inlet flow distortion](#) and transient simulations as well as for turbine design calculations. If *More* is selected as program scope then the inlet radius ratio used for the *Compressor Design* option will be also employed in the engine geometry calculation.

Input data are mass flow W , total pressure P and total temperature T . Furthermore tip speed u_T , axial Mach number M_{ax} and, depending on the configuration, an inlet radius ratio r_h/r_t are required. A



minimum value for the hub diameter can be specified. This option is useful when different fan versions for a family of engines based on the same gas generator are to be studied.

From the Mach number M_{ax} the static data P_s and T_s are found and the given mass flow yields the flow area. This area implies a tip diameter for the prescribed radius ratio. When the hub diameter calculated with this procedure is lower than the prescribed value then the radius ratio is recalculated based on the given hub diameter and the flow area. Angular velocity follows from blade tip speed.

Note that selecting *Compressor Design* will define the properties in the compressor inlet *Thermodynamic Station*.

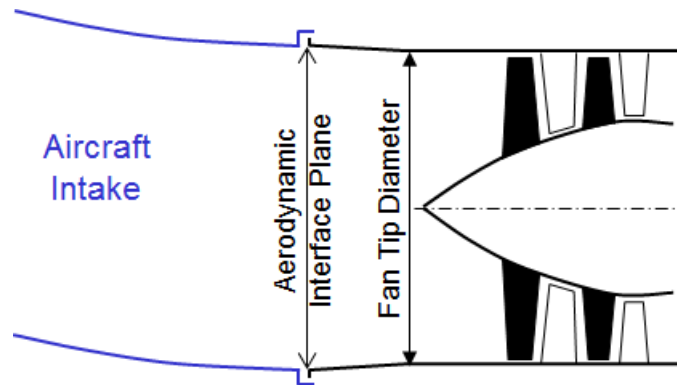

The diameter of the engine inlet at the *Aerodynamic Interface Plane AIP* is derived from the compressor tip diameter. From that diameter one can calculate the flow area at the interface plane:

$$AIP = \left(\frac{d_{AIP}}{d_{C,tip}} \cdot \frac{d_{C,tip}}{2} \right)^2 \cdot \pi$$

The *Aerodynamic Interface Plane AIP* is greater (and the Mach number lower) than the flow area of the compressor inlet thermodynamic station since the latter is the annulus area directly upfront the first rotor blades.

5.4.2 Compressor Calculation

For a given inlet temperature T_1 , pressure ratio P_2/P_1 and efficiency η (isentropic or polytropic) the required specific work $dH_{2,1}$ and the exit temperature T_2 are calculated. First the entropy function ψ for T_1 is evaluated, and is added to the logarithm of the pressure ratio which yields the entropy function for the isentropic exit temperature T_{2is} :

$$\Psi(T_{2is}) = \Psi(T_1) + \ln(P_2/P_1)$$

The inverse of the entropy function gives T_{2is} . Then the isentropic enthalpy rise is divided by the isentropic efficiency to give the effective specific work $dH_{1,2}$

$$dH_{1,2} = \frac{h(T_{2is}) - h(T_1)}{\eta_{is}}$$

Polytropic efficiency is calculated as

$$\eta_{pol} = \frac{\ln(P_2/P_1)}{\ln(P_{2is}/P_1)}$$

and isentropic efficiency as

$$\eta_{is} = \frac{h(T_{2is}) - h(T_1)}{h(T_2) - h(T_1)}$$

During cycle design calculations you can specify either polytropic or isentropic efficiency. Off-design calculations will always read isentropic efficiencies from the component maps.

5.4.3 Compressor Efficiency Estimates

Isentropic compressor efficiency may be estimated as a function of stage loading and corrected flow.

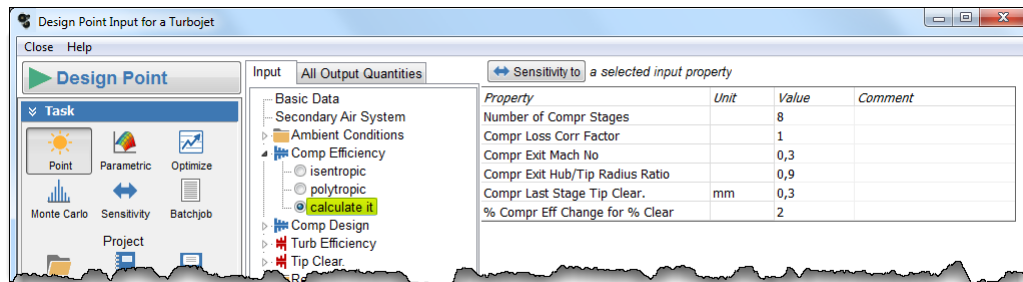

The basis of this calculation are the formulae for advanced technology compressors from Reference 3. The resulting efficiency level can be adjusted with the help of the loss correction factor K_{loss} :

$$\eta = 1 - K_{loss} \cdot (1 - \eta_{advanced})$$

To simulate less advanced compressor stages you must set the loss correction factor to a number greater than one. The value 1.2 means that the losses are 20% bigger than described by the above reference.

In the reference the efficiency correction for compressor size is based on inlet corrected flow as shown in the right part of the figure. Alternatively the efficiency correction can be based on the relative tip clearance of the last rotor.

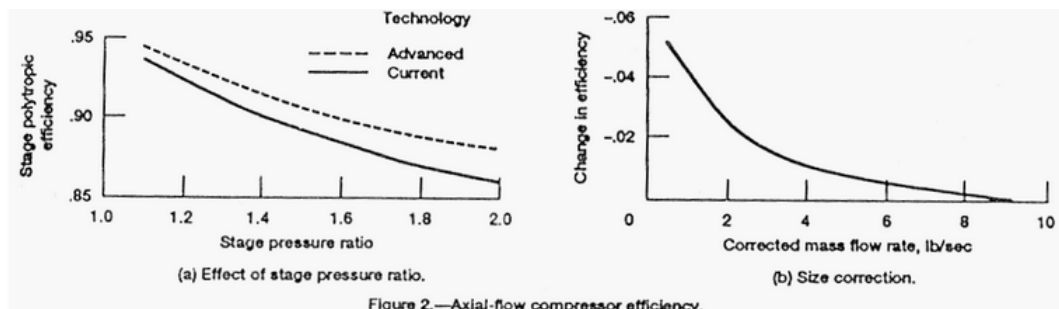

For evaluating the relative tip clearance (= tip clearance/blade height) at the exit of the last rotor, the mass flow, Mach number, hub/tip radius ratio and the absolute running tip clearance are employed. The efficiency decrement is calculated from the relative tip clearance and the exchange rate between efficiency and relative tip clearance.

If you enter zero for the absolute tip clearance then the size correction term will be calculated according to reference 3 mentioned above. Otherwise, the size correction from the report will be replaced by the correlation with the relative tip clearance.

If the scope *More* is selected, the compressor design and efficiency estimates can also be approached in more detail with the [Compressor Aerodynamic Design](#) functionality.



5.4.4 Recirculating Bleed

Bleed air taken from a compressor can be used for de-icing parts in the engine inlet. The injection of the heated air leads to a temperature increase upstream of the first compressor. The amount of this temperature increase can be found only by iteration.

Between the engine inlet and the bleed offtake the water-air-ratio may change (see [wet compression](#)). Such a change in the composition of the recirculating air is not taken into account in the GasTurb 13 simulation.

5.4.5 Wet Compression

Water injection at the first compressor entry can increase the power output of a gas turbine significantly, up to 10% for an injection of only 1% water into the compressor air flow. The water evaporates within the compressor and thus cools the air down. Less specific work is needed for driving the compressor.

For increasing the shaft power delivered one can also inject water into the [combustor](#) or cool the inlet air down by [fogging](#).

For power generation gas turbines and [two-spool mixed flow turbofans](#) you can simulate water injection into a compressor with GasTurb 13 during off-design simulations. Since liquid water enters the compressor we talk about *wet compression*.

The *wet compression* process is described with by the empirical constant *Evaporation Rate $d\ w_{ar} / d\ Temp$* . (here w_{ar} = liquid water-air-ratio). In a first calculation step the overall compression process is calculated as usual which yields the polytropic efficiency. Using this polytropic efficiency the process is recalculated in 20 steps that each consist of a compression step followed by an evaporation step. The amount of water evaporating is calculated from the temperature increase during the compression step and the given *Evaporation Rate $d\ w_{ar} / d\ Temp$* . Thus the amount of gaseous water in the air is continuously increasing while the amount of liquid water is decreasing.

When no liquid water is left while the compression process is not yet finished then the rest of the compression process is calculated with the then existing gaseous water-air-ratio.

If not all of the liquid water evaporates within the compressor then the rest of the liquid water is transferred to the downstream compressor. If downstream there is an [intercooler](#) then it is assumed that the liquid water will be drained and thus leave the engine. If downstream of the compressor the burner follows then the liquid water will be evaporated before the burner calculation commences. If another compressor follows then the liquid water will enter this compressor and the evaporation process continues.

Water injected upstream of the first compressor cools the inlet air down. In this process - called [fogging](#) - water is evaporated before it enters the compressor and the calculation method described above does not apply.

Limitations

In a real engine the liquid water will tend to concentrate along the compressor outer casing. This is because the water droplets that hit the blades will be accelerated to blade speed and then move along the blade surface outwards due to centrifugal force. Finally the droplets will leave the blades and many of them will hit the casing and create a water film. Some of the water moving along the casing will disappear in the offtakes that are located there.

As mentioned above, GasTurb 13 assumes that the water is evenly distributed over the gas stream and thus the effects of local water concentrations will not be taken into account.

Gas properties are stored for dry air, air with 3% gaseous water-air-ratio and 10% gaseous water-air-ratio. Water flow rates caused by the incoming humidity, inlet fogging, water and steam injection that yield together more than 10% water-air-ratio will lead to extrapolation of the gas property data tables. It is up to the user to decide whether the error introduced by this extrapolation of the gas property tables is acceptable or not.

5.4.6 Work done on Liquid Water

Some of the liquid water flowing through a compressor will hit the blades and attach to their surface. This liquid water is accelerated to the circumferential speed of the blade and this requires some power. The water then flows in a film along the surface of the blade until it reaches the trailing edge or the blade tip. After leaving the blade many of the water droplets will hit the downstream vanes or the casing and lose their circumferential speed. In the next stage the droplets hitting the rotor need again some power to accelerate to blade speed.

According to Reference 1 the work done in each stage of an axial compressor is

$$PW = 0.5 \cdot W_{H_2O} \cdot U^2$$

with

W_{H_2O}	Liquid water mass flow [kg/s]
U	Circumferential speed of the blade [m/s]
PW	Shaft power required per stage [kW]

The power required for the liquid water in a compressor is calculated from

$$PW = C_{PW_{H_2O}} \cdot W_{H_2O} \cdot PW_{qH_2O} \cdot N_{rel}^2$$

with

N_{rel}	The relative spool speed (equal to 1.0 at the design point)
PW_{qH_2O}	A value in the range from 0 to 1 which takes into account the decreasing amount of liquid water in the later stages due to evaporation within the compressor. This value is found automatically, it is not an input quantity.
W_{H_2O}	Liquid water mass flow at the entry to the compressor in [kg/s] respectively [lbm/s]
$C_{PW_{H_2O}}$	Power/WH ₂ O, I @ Nom.Speed

$C_{PW_{H_2O}}$ is an input value in the units [kW/(kg/s)] respectively [hp/(lbm/s)] which takes into account:

- the empirical constant 0.5 from Reference 1, see above
- the conversion of relative spool speed to the mean circumferential speed of the blades in m/s
- the number of compressor stages
- a unit conversion factor of 1/1000 which converts from W to kW

Example:

For a six stage compressor with a mean blade speed of 500m/s an appropriate value for $C_{PW_{H_2O}}$ would be

$$C_{PW_{H_2O}} = 0.5 \cdot 500^2 \cdot 6 / 1000 = 750 \text{ kW/(kg/s)}$$



5.4.7 Inlet Flow Distortion

5.4.7.1 Parallel Compressor Theory

Only the first compressor of an engine can operate without inlet flow distortion - and that only while the uninstalled engine is running on a testbed. Installed in an aircraft often there are more or less severe pressure non-uniformities at the engine face. In some cases, during thrust reverser operation, for example, the engine inlet temperature is also not uniform. In these cases the downstream compressors see both pressure distortions and temperature distortions. GasTurb 13 allows for simulating the effects of both total pressure and total temperature distortion on compressor system stability.

The most appropriate method to simulate flow distortion effects within performance synthesis programs is the parallel compressor theory, see Reference 26. In its simplest application the distorted flow field upstream of the compressor is characterized by two streams with different, but uniform, total pressures. Each stream enters one of two imaginary compressors working in parallel. Both compressors have the same map – the one measured on the rig with clean inlet flow - except for the flow capacity. If the spoiled sector width is 60°, for example, the flow capacity of the first imaginary compressor is $60^\circ/360^\circ = 1/6$ (the spoiled sector). The second compressor covers a 300° sector and has $300^\circ/360^\circ = 5/6$ of the real compressor's capacity:

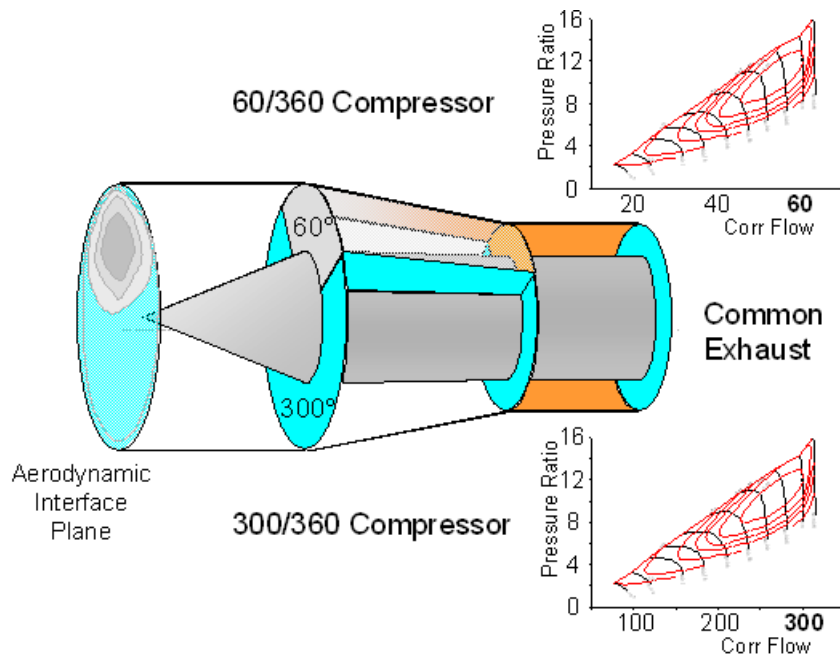

The basic hypothesis of the parallel compressor theory suggests that both compressors discharge to the same static pressure in the downstream duct. This condition allows for calculating the operating point positions in the respective maps.

In the special case with distortion sectors of 180° the two compressor flow capacities are of equal size. As can be seen in the upper part of the next figure (total pressure distortion), the compressor dealing with the low inlet pressure operates with a higher than average pressure ratio and for the other compressor the opposite holds true. Both operating points are on the same speed line because both sectors have the same inlet total temperature. The two operating points move away from each other when the distortion intensity increases. As soon as the point marked L reaches the surge line, the stability boundary of the total compressor is reached according to the parallel compressor theory. The compressor is predicted to surge in spite of the fact that the mean operating point M is still far from the (clean) surge line.

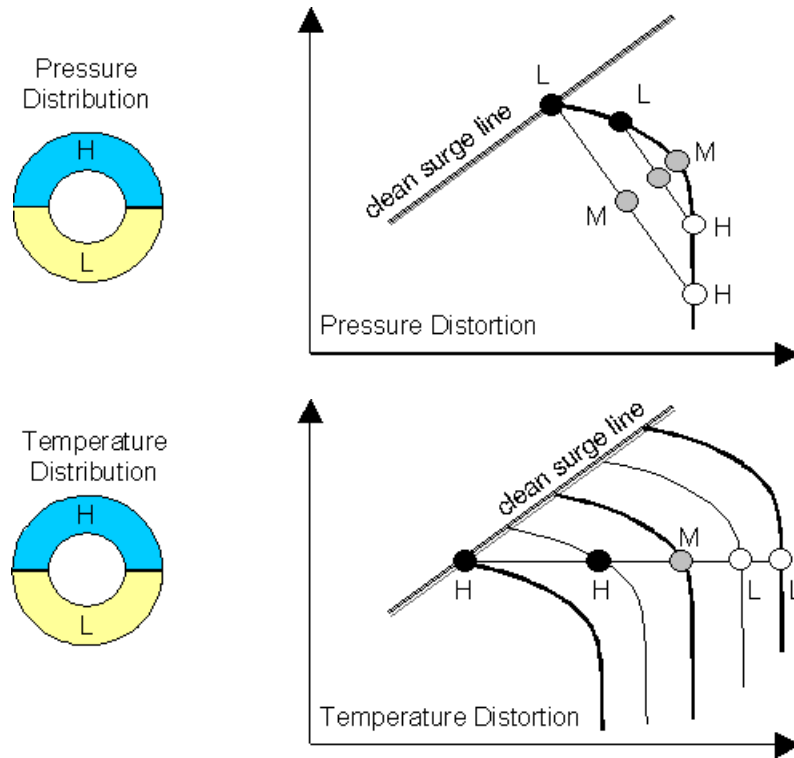

The parallel compressor theory can be applied also to temperature distortion simulation. In this case the pressure ratios of the two compressors are similar, but the operating points are on different speed lines as shown in the lower part of the figure.

In its basic form the parallel compressor model gives the right tendencies but does not agree very well with reality in terms of absolute numbers for small circumferential extent inlet distortion patterns because it yields the highest loss in stall margin for zero width of the distorted sector:

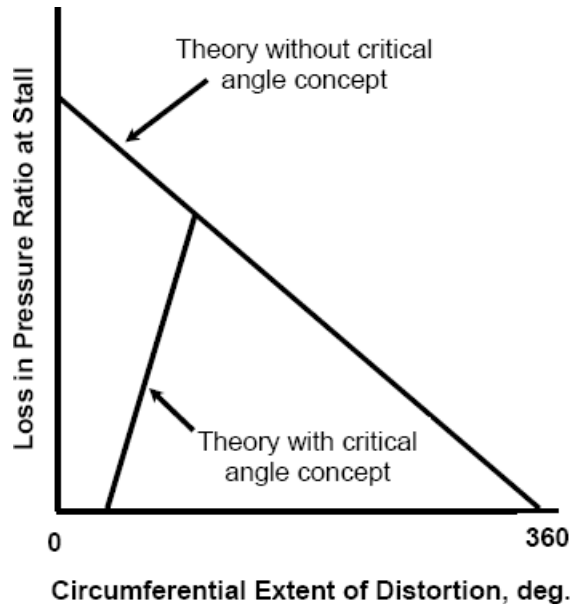

Obviously the loss in stall margin must be zero when the distorted sector width is zero degree and also when it is 360 degree. Somewhere between zero and 360 degree sector width - at the critical sector angle - the loss of stability is maximum. Some corrections to the parallel compressor theory are described in [References 14 and 15](#).



5.4.7.2 Compressor Coupling

As mentioned above, the parallel compressor theory postulates that at the exit of the compressor the static pressure is circumferentially uniform. Since the pressure ratio, however, is different, the total temperature at the exit of the compressor will not be uniform. If there follows a further compressor downstream of the first one, then the two operating points in the map of the second compressor will no longer be on the same speed line. This has a more detrimental effect to the stability than a pure pressure distortion.

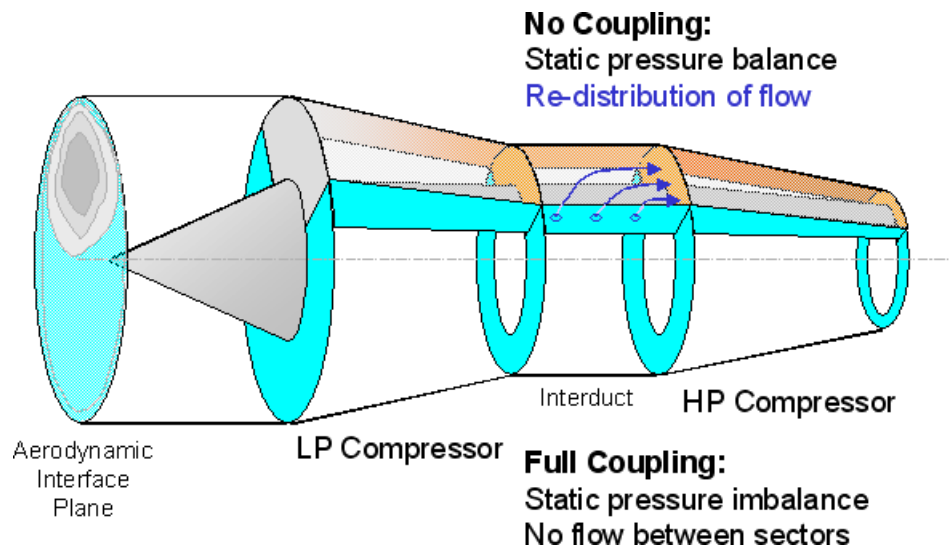

The parallel compressor model as presented above can lead to serious errors in engine distortion tolerance estimates and in the diagnosis of the "critical" compressor with multi-spool engines. These compressors are connected either with no ducts in between or with short swan neck shaped ducts that contain many vanes or struts. These reduce or even prevent the mass flow over the sector boundaries which would be required for achieving the static pressure balance between the sectors. Consequently the static pressure field of the downstream compressor affects the upstream compressor: the compressors are close-coupled, see Reference 14.

Full coupling of compressors is taken into account by GasTurb 13 in such a way that in inter-compressor ducts the condition of "equal static pressures" (no coupling) is replaced by the condition "no mass flow between sectors", see Reference 26.

For describing any sort of inter-compressor duct (short, long, with and without vanes) it is convenient to introduce a *Coupling Factor CF* which allows using a linear combination of the conditions "equal static pressures" (CF=0) and "no flow between sectors" (CF=1). With higher values of the *Coupling Factor*, the two operating points for the upstream compressor are closer together so there is a decreased loss in upstream compressor surge margin.

5.4.7.3 Pressure Distortion

In GasTurb 13 you can select either pressure or temperature distortion or a combination of both for a given sector angle. *Radial distortion* can be specified for bypass engines also. Engine inlet flow distortion is described by pressure and *temperature distortion coefficients*.

The pressure distortion coefficient for a 60° sector is defined as

$$DC_{60} = \frac{P_{mean} - P_{60^\circ sector}}{\rho \cdot V^2 / 2}$$

This coefficient is defined in the *aerodynamic interface plane*. Reasonable numbers for the pressure distortion coefficient are in the range 0 ... 1.5

In the compressor maps you will see the operating points in both sectors and the type of distortion will be indicated. Note that the compressors downstream of the first compressor will encounter a temperature distortion even in the case, where only a pressure distortion is specified.

5.4.7.4 Temperature Distortion

The temperature distortion coefficient for a 60° sector is defined as

$$DT_{60} = \frac{T_{60^\circ \text{sector}} - T_{\text{mean}}}{T_{\text{mean}}}$$

Be careful with the input of values for the distortion coefficients. Begin with low numbers, especially for temperature distortion. The iteration will not converge when the solution implies operating conditions in the spoiled sector well above the surge line. Reasonable numbers for the temperature distortion coefficient are in the range 0 ... 0.1

The total temperature in the spoiled sector $T_{2,\alpha}$ is

$$T_{2,\alpha} = \frac{\left(1 - \frac{\alpha}{360^\circ}\right) \cdot (1 + DT_\alpha)}{1 - \frac{\alpha}{360^\circ} \cdot (1 + DT_\alpha)} \cdot T_2$$

5.5 Gearbox

Gearbox losses are modeled as mechanical efficiency of the spool to which the gearbox is attached. With the help of [composed values](#) and a user defined iteration you can make the gear box efficiency follow any correlation you want.

5.6 Duct Pressure Losses

The pressure losses in a duct are specified in cycle design calculations as a pressure ratio $(P_2/P_1)_{ds}$. During off-design simulations the pressure losses vary according to

$$\frac{1 - \frac{P_2}{P_1}}{\left(1 - \frac{P_2}{P_1}\right)_{ds}} = \left(\frac{\frac{W \cdot \sqrt{R \cdot T}}{P}}{\left(\frac{W \cdot \sqrt{R \cdot T}}{P}\right)_{ds}} \right)^2$$

Normally the design point pressure ratios are not visible during off-design simulations, however, you may [change that](#). If you input a duct pressure ratio during off-design simulations you will not get this value as a result because the input does not specify the pressure ratio P_2/P_1 directly but alters $(P_2/P_1)_{ds}$ in the formula above. Similarly the [Modifiers](#) for duct pressure losses do not affect P_2/P_1 , they affect $(P_2/P_1)_{ds}$.

Note that the pressure losses in [turbine inter-ducts](#) and [exhaust ducts](#) are handled differently while [Turbine Design](#) is selected for the upstream turbine.



5.7 Intercooler

An intercooler will cool the gases down to a specified temperature and create some pressure losses. These will vary in the simulation as in any duct proportional to the square of the corrected flow.

Liquid water entering the intercooler will be drained. Condensing of water resulting from the gaseous humidity of the incoming air is not considered. With other words the gaseous humidity does not change in the intercooler as simulated in GasTurb 13.

5.8 Heat Exchanger

5.8.1 Simulation Options

There are two methods implemented for the simulation of recuperators (also dubbed heat exchanger or regenerator).

Method 1

Input data are the [effectiveness](#) and the design pressure ratios on the cold and the hot side. The pressure losses vary in off-design as a function of corrected inlet flow squared as in a [normal duct](#). Effectiveness is assumed to remain constant during off-design operation.

Method 2

Input data are the design effectiveness and the design pressure ratios on the cold and the hot side. In off-design the effectiveness increases at part power because the mass flow decreases while the heat transfer surface remains constant. As stated in [Reference 1](#) the following formula is a good first order accuracy:

$$\eta = 1 - \frac{W}{W_{ds}} \cdot (1 - \eta_{ds})$$

This simple relationship holds because the downside flow capacity is essentially fixed by that of the high pressure turbine.

The pressure losses on the cold side (air side) increase at part power due to increased heat transfer while the exit corrected flow remains approximately constant. On the hot side (gas side) the corrected flow at the inlet decreases significantly and thus also the pressure loss. The following formulas are taken from reference 1:

Cold side:

$$\frac{P_1 - P_2}{P_1} = \left(\frac{P_1 - P_2}{P_1} \right)_{ds} \cdot \frac{\left(\frac{W_1}{P_1} \right)^2 \cdot \frac{T_2^{1.55}}{T_1^{0.55}}}{\left(\frac{W_1}{P_1} \right)_{ds}^2 \cdot \frac{T_{2,ds}^{1.55}}{T_{1,ds}^{0.55}}}$$

Hot side:

$$\frac{P_1 - P_2}{P_1} = \left(\frac{P_1 - P_2}{P_1} \right)_{ds} \cdot \frac{W_1^2 \cdot T_1}{(W_1^2 \cdot T_1)_{ds}}$$

5.8.2 Bypass Valve

In the two spool turboshaft a bypass valve for the heat exchanger can make sense if the engine is used for vehicle propulsion. Ground vehicles like tanks operate over a long time at low part power and need the maximum power rather seldom. In such an application one can use a comparatively small heat exchanger to keep the volume of the engine within limits. An undersized heat exchanger works fine at part power, however, it would create tremendous pressure losses at full power. The heat exchanger bypass allows keeping the pressure loss of the heat exchanger at maximum power within reasonable limits and thus increases the maximum power available. Specific fuel consumption will increase, but that is not important due to the short duration for which maximum power is needed.

The heat exchanger bypass is not implemented in the single spool turboshaft configuration.

5.9 Combustor

5.9.1 Temperature Rise

The temperature rise in a burner due to combustion of hydrocarbon fuel depends on the gas entry temperature to the burner, the injected fuel-air-ratio, water-air-ratio, the static pressure in the burner and the [chemical composition of the fuel](#).

Numbers for the temperature rise due to combustion are stored in tables that are created using the computer code described in [References](#) [12] and [13]. All sorts of combustion products as well as the influence of pressure are taken into account. Thus the effects of dissociation on the temperature rise in a combustor is allowed for.

5.9.2 Off-Design Efficiency

Modern combustion chambers have very high efficiency at design conditions. At part load near idle and at very high altitude, however, the burner efficiency can deviate noticeable from 100%.

Burner efficiency can be correlated with burner loading which is defined as

$$\Omega = \frac{W_{31}}{P_3^{1.8} \cdot e^{T_3/300K} \cdot Vol}$$

with

W_{31}	Air mass flow
P_3	Pressure [bar]
T_3	Inlet temperature [K]
Vol	Burner volume [m ³]

For the cycle design point in GasTurb 13 the burner efficiency is an input and the burner loading is by definition equal to 100%. For part load conditions the relative burner loading Ω/Ω_{des} can be determined without knowing the burner volume because the volume is invariant

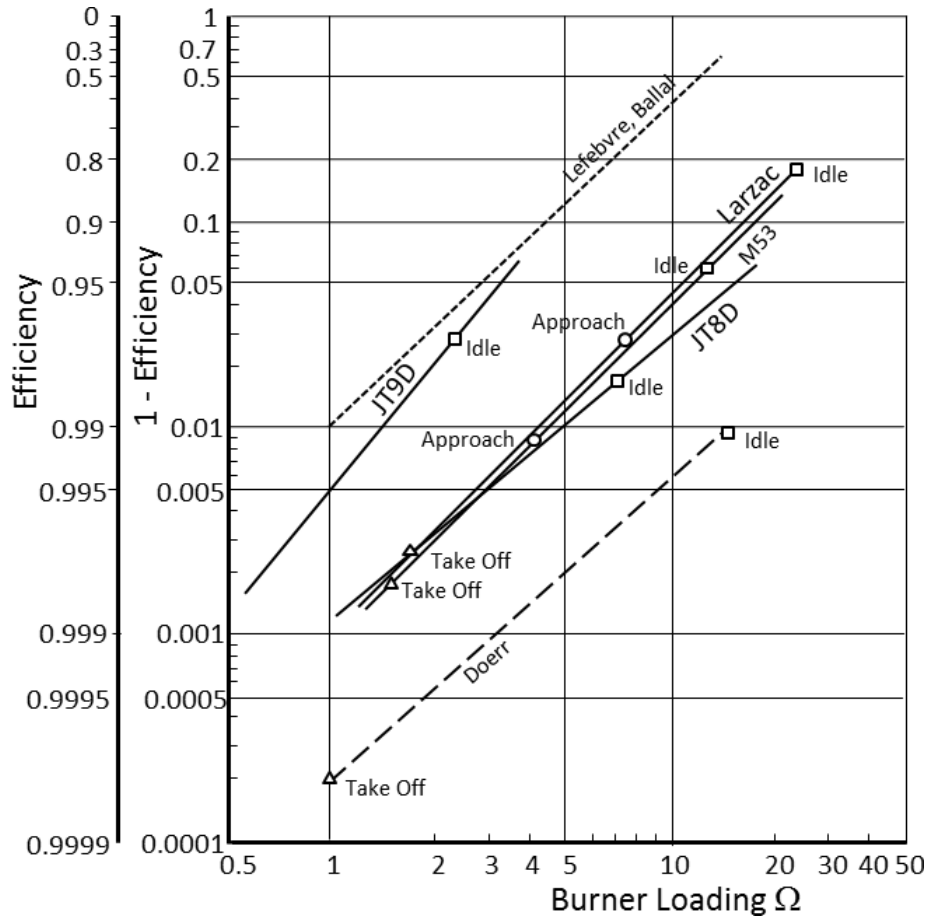

The figure above is taken from Reference 10 and shows that the change in burner efficiency with load can be approximated by

$$\log(1 - \eta) = a + b \cdot \log(\Omega / \Omega_{ds})$$

The constant a in this formula is correlated with the design point efficiency:

$$a = \log(1 - \eta_{ds})$$

Thus it is possible to describe the burner part load efficiency trend with a single property, the *burner part load constant b*.

Some authors use instead of burner loading the burner loading parameter Θ which is the inverse of Ω . In the next two figures there are scales for both Ω and Θ . The first figure shows off-design efficiencies with the burner part load constant of 1.6 (the GasTurb default value) in combination with various burner design point efficiencies.

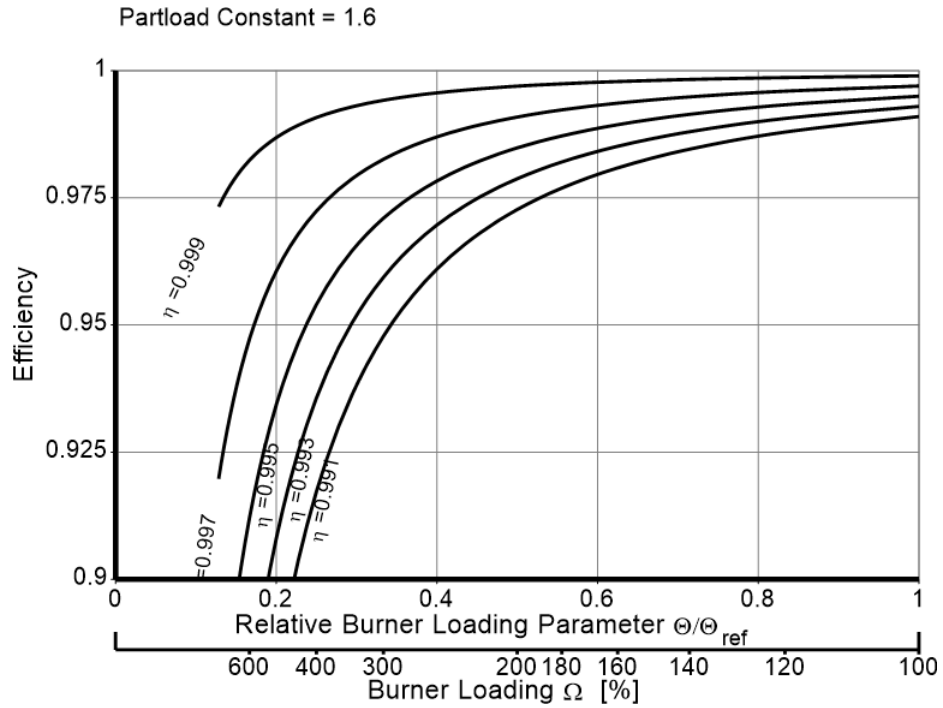

The effect of the part load constant on the burner efficiency is shown in the figure below for an example with cycle design point efficiency of 0.999.

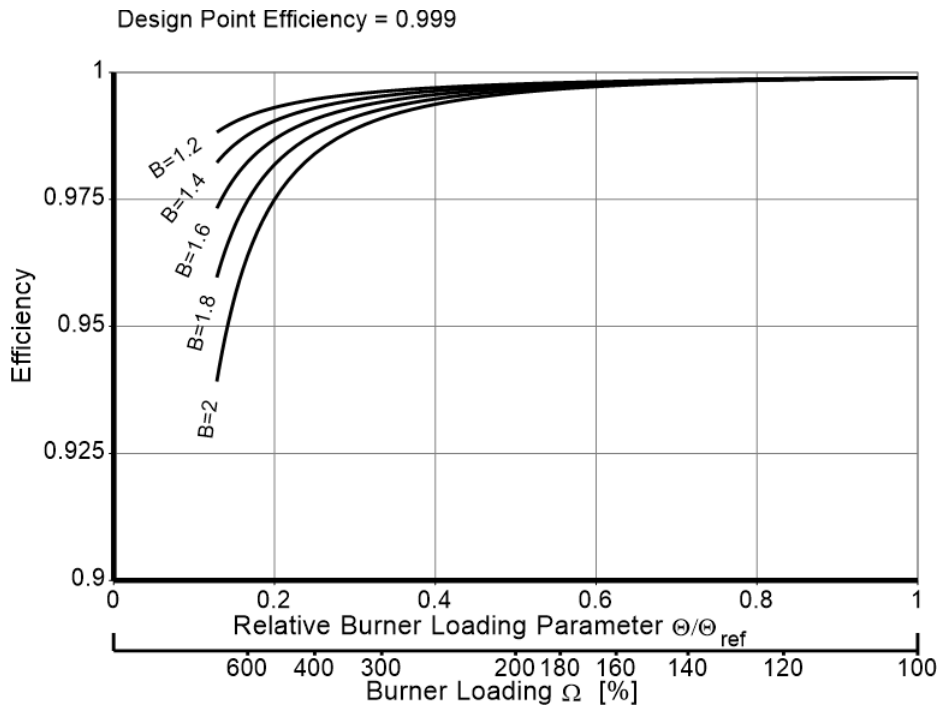

If this simulation methodology is not appropriate for your type of burner then you can employ [Composed Values](#) with a [General Table](#) to calculate burner efficiency. Iterate *Burner Design Efficiency* such that the calculated burner efficiency is equal to the composed value. Note that during off-design simulations the *Burner Design Efficiency* is selectable as iteration variable only after it has been made an input quantity.



5.9.3 Pressure Losses

There are two reasons for pressure losses in combustion systems: friction and heat addition. Pressure losses due to friction are given as pressure ratio P_4/P_3 in the cycle design point. During off-design simulations the pressure losses vary proportional to corrected burner inlet flow squared as in any duct.

Pressure losses due to heat addition are neglected in the main burner. In reheat systems the [pressure losses](#) are calculated from the *Rayleigh line*, i.e., a constant area duct without friction is assumed and from conservation of momentum the pressure loss is found.

5.9.4 Sequential Combustion

We talk of *Sequential Combustion* if after the high pressure turbine a second combustor reheats the gas before it enters the low pressure turbine. The temperature increase in the second combustor is described with the *Degree of Reheat* which is expressed in percent. If the *Degree of Reheat* is 100%, the exit temperature of the second burner will be equal to T_4 ; 0% *Degree of Reheat* means that the second burner is switched off.

If [water and steam injection](#) is selected then in GasTurb 13 all the water goes to the first combustor because there most of the NO_x is produced due to the high pressure. If steam is injected for cooling the downstream turbines, then the input data are applied to both the high and low pressure turbines.

5.9.5 Emissions

The combustion products of hydrocarbon fuel with air are mainly water and carbon dioxide. Thus the emission of CO_2 is directly coupled to the fuel consumption of a gas turbine. At full load additionally [nitrogen oxides](#) NO_x are produced while at part power [carbon monoxide](#) CO and [unburned hydrocarbons](#) UHC are the problem.

5.9.5.1 NO_x

The production of nitrogen oxides increases with pressure, temperature and residence time in the combustor while water in the combustion air reduces the amount of nitrogen oxides. The *NOx Severity Parameter* S_{NO_x} is in [Reference 8](#) defined as

$$S_{\text{NO}_x} = \left(\frac{P_3}{2965 \text{ kPa}} \right)^{0.4} \cdot e^{\left(\frac{T_3 - 826 \text{ K}}{194 \text{ K}} + \frac{6.29 - 100 \cdot \text{war}}{53.2} \right)}$$

Consequently, reduction techniques focus on just what latitude one has with these variables in view of the engine cycle requirements. Not only is temperature the most sensitive of these, but owing to the design of conventional burners, it also offers the greatest possibility for control. In the conventional engine, fuel is initially burned at approximately stoichiometric conditions and subsequently diluted to the desired leaner condition. The high temperatures in the primary combustion zone result in rapid production of NO_x during its residence time and set the value of the final emission level. The advantages of this arrangement are that the hot, stoichiometric primary zone provides good stability, ignition and relight, while the addition of dilution air allows convenient cooling of the combustor liner.

The low- NO_x burners are consequently designed to avoid the hot stoichiometric and dilution zones, thereby reducing emissions, but at the expense of stability and cooling problems.

Note that the water-air-ratio (war) term in this formula describes only the effect of ambient humidity, the reduction of NO_x due to water or steam injection into the combustor is a different subject. According to Ref. 28 the relationship between NO_x reduction and water or steam injection can be described by

$$\frac{NO_{x,wet}}{NO_{x,dry}} = e^{-f_{NO_x,war} \cdot (0.2 \cdot wfr^2 + 1.41 \cdot wfr)}$$

The term wfr stands for water-fuel-ratio. This formula applies for both liquid and gaseous fuels. Since the equation in its original form is not universally applicable, the *NOx Reduction Factor* $f_{NO_x,war}$ is introduced in GasTurb 13. The default value of 1.0 means that no correction to the above formula is applied. Setting the *NOx Reduction Factor* to 0 means that water or steam injection have no influence on NO_x generation.

The *NOx Emission Index EI* [g/kg fuel] increases linearly with the NO_x severity parameter. For conventional combustors holds

$$EI \approx 32 \cdot S_{NO_x}$$

while for dual annular combustors the NO_x emission is approximately

$$EI \approx 23 \cdot S_{NO_x}$$

5.9.5.2 CO and HC

Incomplete combustion results in the production of carbon monoxide CO and unburned hydrocarbons UHC. The amount of these species can be correlated with the combustion (in)efficiency, see [Reference 9](#):

$$100 - \eta = 0.1 \cdot (0.232 \cdot EI_{CO} + EI_{UHC})$$

with EI = Emission Index, gram emission per kilogram fuel.

There is a relationship between the two emission indices:

$$\log(EI_{UHC}) = C_1 \cdot \log(EI_{CO}) + C_2$$

Data from an extensive measurement campaign with the CFM56 engine correlate well if $C_1 = 3.15$ and $C_2 = -4.3$ are used in this formula.

5.10 Turbine Design

5.10.1 Turbine Design

A preliminary turbine design procedure may be selected during cycle design; select "calculate it" for *Turbine Efficiency*. It does turbine geometry and efficiency calculations for axial turbines on a mean section basis assuming symmetrical diagrams for each stage (except the first stage, which has axial inlet flow).

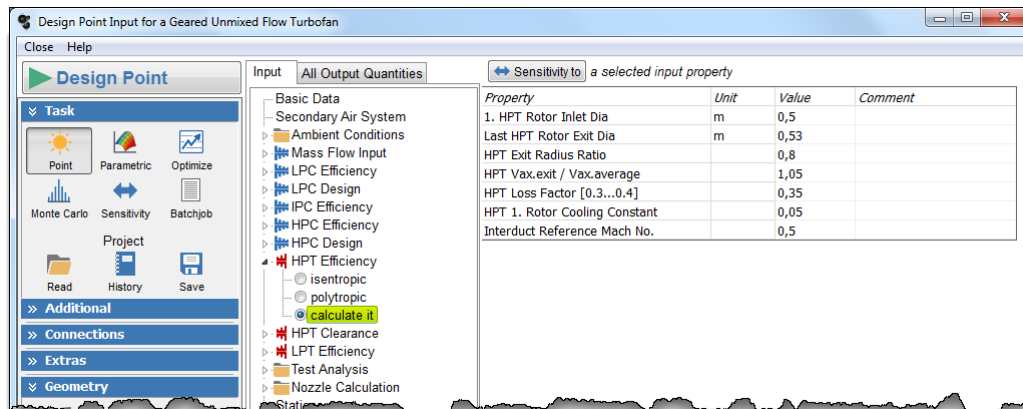

The basic parameter for the efficiency estimation is the aerodynamic loading parameter. Other factors affecting the efficiency level are the number of stages (input on the *Secondary Air System* page), stator exit angle and average specific kinetic energy within the blade rows, Reynolds number and turbine-exit axial component of velocity head.

The losses in the turbine stage are assumed to be proportional to the following:

- The tangent of the stator exit angle, measured against the turbine axis. This correlation reflects the variation in the ratio of flow area to surface area
- The average specific kinetic energy within the blade rows based on entering and leaving velocities. For rotors the losses of kinetic energy are assumed to be twice as big as for stators.
- Reynolds number to the $-1/5$ power. This assumption represents the normal manner which the loss is assumed to vary with Reynolds number.

Inlet and exit mean diameters are defined at the rotor exit, for single-stage turbines both data are the same. The axial velocity ratio $V_{ax,exit}/V_{ax,average}$ is the ratio of exit axial velocity over mean axial velocity.

Efficiency calculated by the program can be adjusted to any technology level by adapting the loss coefficient K_{loss} . The NASA report ([Reference 11](#)) - which is the basis of the calculation procedure - proposes K_{loss} in the range of 0.35 to 0.4. Large uncooled turbines of modern engines can be better described with values as low as 0.3.

Flow angles are measured relative to the turbine axis. Positive angles are in the direction of rotation. You will get useful results for the efficiency from turbine design only for a limited range of input data. The diameters needed for input can be estimated from compressor calculations: a good first estimate for the mean high pressure turbine inlet diameter is the high pressure compressor inlet tip diameter.

Optionally, a [tip clearance correction](#) can be applied to the calculated efficiency of high-pressure turbines.

The *Interduct Reference Mach No.* for calculating the turbine inter-duct loss between a high and a low-pressure turbine is a further input. If it is set to zero, then the input value for the inter-duct pressure ratio will be used. Otherwise, the Mach number downstream of the turbine will influence the downstream [duct pressure loss](#).

Note that selecting *Turbine Design* will also determine the properties at the turbine exit [Thermodynamic Station](#).

5.10.2 Blade Metal Temperature

The blade metal temperature determination is part of a [turbine design](#) calculation. First the cooling effectiveness is evaluated from an empirical correlation. The *HPT 1. Rotor Cooling Constant* must be

adjusted to the application for getting reasonable results. Finally the blade metal temperature is calculated from

$$T_{Metal} = T_{rel} - \eta_{cool} \cdot (T_{rel} - T_{coolingair})$$

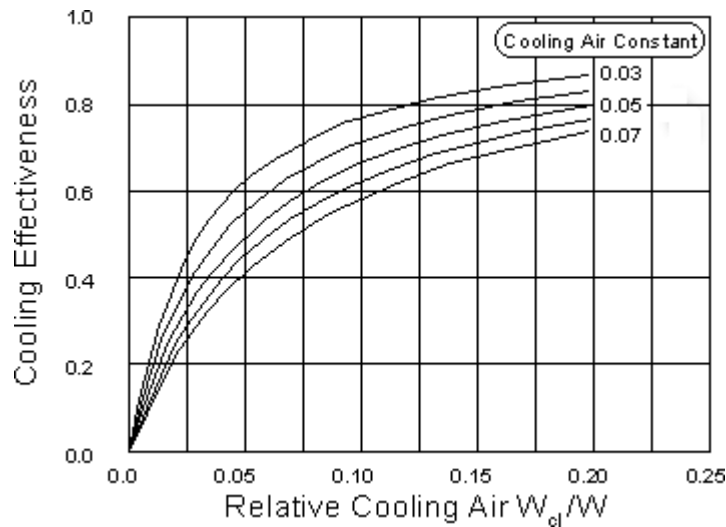

5.10.3 Turbine Tip Clearance Correction

Turbine tip clearance has a strong effect on efficiency as can be seen from the figure below (taken from Reference 7):

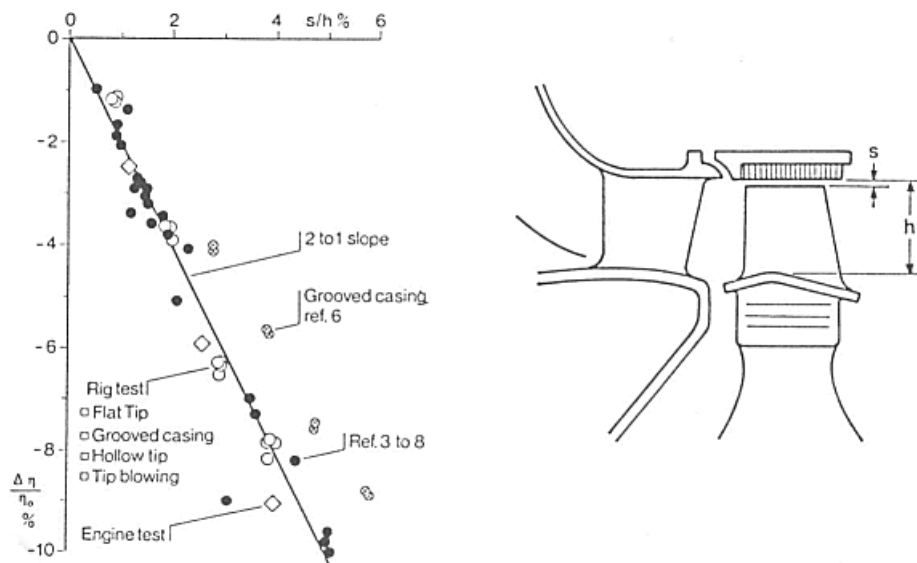

Fig. 2: Effects of Tip Clearance on the Efficiency of Single Stage Shroudless Turbines [1].

The results of an high pressure turbine design calculation can be modified with the turbine tip clearance correction which uses the absolute tip clearance and the exchange rate of efficiency with relative tip clearance (see figure above) as input.

5.10.4 Blade Root Stress

The centrifugal pull of a single turbine blade is several tons and this load must be transferred uniformly through the attachment to the disk. The centrifugal stress σ of a blade at its root can be estimated as follows:



$$\sigma = \frac{F}{A_h} = \rho \cdot \omega^2 \cdot \int_{r_h}^{r_t} \frac{A_{blade}(r)}{A_{blade,h}} \cdot r \cdot dr$$

The blade cross-sectional area usually reduces with increasing radius which results in less stress at the root. With a linear decrease of cross-sectional area it can be shown that the blade root stress will not exceed for any hub/tip radius ratio the value

$$\sigma_{\max} = \frac{\rho \cdot \omega^2 \cdot A}{4\pi} \cdot \left(1 + \frac{A_{blade,t}}{A_{blade,h}} \right)$$

In this expression is

$$A = \pi \cdot (r_t^2 - r_h^2)$$

A common simplification ignores the effect of material density and blade taper (respectively assumes that material density and blade taper are more or less the same for all the engines to be studied) which leads to the simple stress criterion $A \cdot N^2$. Since with multi-stage turbines the last stage annulus area is the biggest, $A \cdot N^2$ is evaluated at the last rotor blade mean annulus area.

In GasTurb 13 AN^2 is found from

$$AN^2 = \pi \cdot d_{mean}^2 \cdot \frac{1 - \frac{d_i}{d_o}}{1 + \frac{d_i}{d_o}} \cdot RPM^2 \cdot 10^{-6}$$

In summary AN^2 is a measure of the disk rim stress and it is a key design parameter that links the aerodynamic design to the mechanical limitations. Usually it is expressed as the product of the turbine exit area in square inches and the maximum mechanical design speed in rpm. A typical value for AN^2 might be $4.5 \cdot 10^{10}$ in²rpm². The values of design limits are chosen according to the density of the blade material and the level of technology assumed in a particular preliminary engine design exercise.

5.11 Turbine Performance Calculation

Quoting numbers for the efficiency of a turbine is ambiguous if it is not known how this efficiency is defined. This is especially true for a heavily cooled turbine where for the same machine the efficiency may be quoted as 88% or 91%, for example. In aero-engine industry, several different turbine efficiency bookkeeping systems are in use. Since nearly always a consortium of two or more companies is involved into any new engine project it is important to understand the various bookkeeping systems.

There are two basically different methodologies for defining the efficiency of a cooled turbine: One can deal with the turbine as a sort of "black box" or go into the details of the expansion process. A discussion about the merits of the different efficiency definitions can be found in [Reference 2](#).

In GasTurb 13 cooled multistage turbines are simulated as [equivalent single stage turbines](#). The [thermodynamic turbine efficiency](#) is provided as an output property which can be employed as iteration target.

In the chapter "Calculation Options" of the GasTurb Details 6 manual is described how to derive input data for the methodology employed by GasTurb 13 from numbers for other efficiency definitions and for more complex secondary air systems than those simulated in GasTurb 13.

5.11.1 Un-Cooled Turbine

For a given inlet temperature T_1 , specific work $dH_{1,2}$ and efficiency η (isentropic or polytropic) the pressure ratio P_1/P_2 and the exit temperature T_2 are calculated. First the isentropic specific work is found from specific work and isentropic efficiency. This gives the isentropic exit temperature $T_{2,is}$:

$$h(T_{2,is}) = h(T_1) - \frac{dH_{1,2}}{\eta_{is}}$$

The difference in the entropy functions for T_1 and $T_{2,is}$ is equal to the logarithm of the pressure ratio. From this it follows that

$$P_2 = P_1 \cdot e^{\Psi(T_{2,is}) - \Psi(T_1)}$$

The exit temperature is found easily by using the enthalpy $h_2 = h_1 - dH_{1,2}$. Polytropic and isentropic efficiencies are calculated as

$$\eta_{pol} = \frac{\ln(P_1/P_{2,is})}{\ln(P_1/P_2)}$$

$$\eta_{is} = \frac{h(T_1) - h(T_2)}{h(T_1) - h(T_{2,is})}$$

5.11.2 Cooled Turbine

The figure shows a cooled single-stage high pressure turbine with a typical cooling air supply system. Compressor exit bleed is the source of the cooling air, and the control volume is identical to the turbine annulus. The power created within the control volume must be bigger than the net power available at the shaft because disk windage and accelerating the cooling air to blade velocity requires some power.

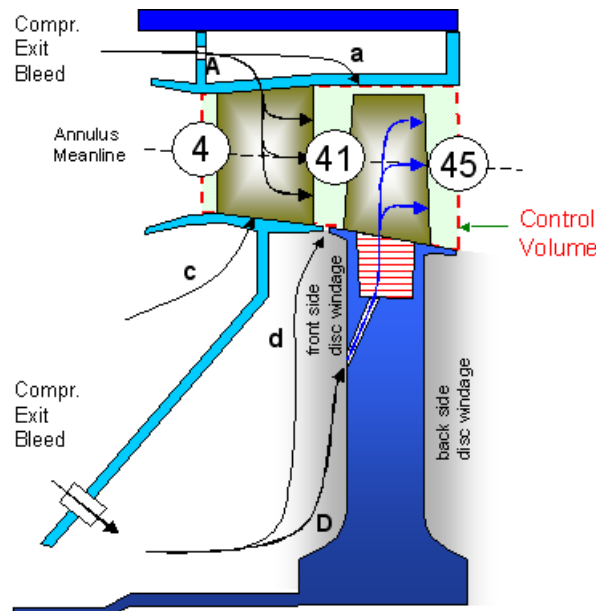

With the most widely used efficiency definition, described for example in [Reference 1](#) for each cooling air stream it is considered whether it does work in the turbine or not. For example, all stator (vane) cooling air is said to do work in the rotor. Thus the *Rotor Inlet Temperature* (RIT, also called *Stator Outlet Temperature* SOT or T_{41}) is calculated by mixing energetically the mass flow W_4 and the stator vane cooling air W_A :



$$h(T_{41}) = \frac{W_4 \cdot h(T_4) + W_A \cdot h(T_3)}{W_4 + W_A}$$

Platform cooling air W_c and disk rim sealing air W_d normally are not considered when T_{41} is calculated since these parasitic flows do not have the potential to do work in the rotor because of lack of momentum. Also the rotor cooling air W_D and the liner cooling air W_a cannot do any useful work in the rotor. Therefore these streams are not considered when calculating the expansion process from station 41 to station 415. They are mixed energetically together with the above mentioned parasitic flows downstream of the rotor between stations 415 and 45. The figure below shows the calculation in the enthalpy-entropy diagram.

$$\eta_{stage} = \frac{PW_{SD}}{W_{41} \cdot \Delta H_{is}}$$

with

- PW_{sd} Shaft power delivered
- ΔH_{is} Isentropic specific work of rotor mass flow for the expansion to P_{45}

With this approach the expansion process in the rotor is the same as in an uncooled turbine, and therefore the number used for the efficiency can be understood as that for an uncooled turbine.

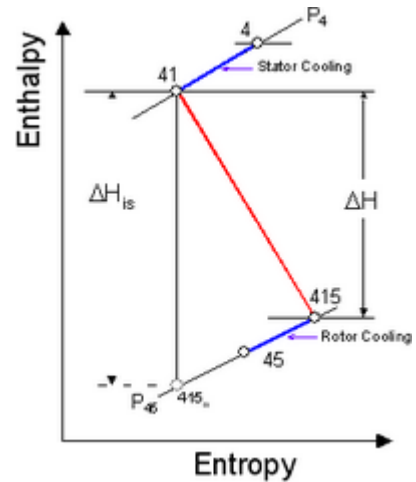

5.11.3 Thermodynamic Turbine Efficiency

The second most used efficiency definition for a cooled turbine is called in literature the thermodynamic efficiency. In this approach the turbine is dealt with as a black box which converts thermal energy into shaft power. The input into this black box are the main stream energy flow $W_4 \cdot h(T_4)$ and many secondary air streams $W_i \cdot h(T_i)$. All of these energy streams have the work potential which results from an isentropic expansion from their individual total pressure P_i to the turbine exit pressure P_{45} .

The thermodynamic efficiency is defined as

$$\eta_{th} = \frac{PW_{SD} + PW_{pump}}{W_4 \cdot \Delta H_{is} + \sum W_i \cdot \Delta H_{i,is} + \sum W_k \cdot \Delta H_{k,is}}$$

The cooled turbine process is shown in the enthalpy-entropy diagram below. Note that within this definition no stator outlet temperature needs to be calculated. PW_{pump} is the shaft power required to accelerate the rotor cooling air to blade velocity (= *Cooling Air Pumping Diameter* * rotational speed)

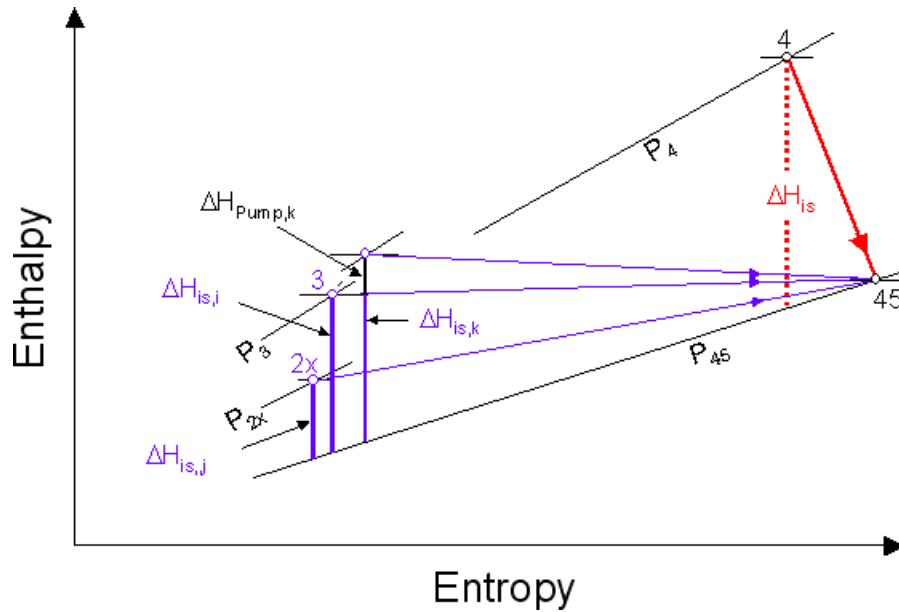

The advantage of this turbine efficiency definition is that no assumptions have to be made about the work potential of the individual secondary streams. The work potential of these streams is defined via their respective pressures and temperatures, which at least theoretically all can be measured. Thus the thermodynamic turbine efficiency is less ambiguous than the equivalent single stage efficiency. Moreover, the thermodynamic turbine efficiency accounts for the pressure of the secondary streams while other definitions do not.

The thermodynamic turbine efficiency is calculated within GasTurb 13 as an output property.

5.11.4 Turbine Interduct Pressure Loss

In cycle design calculations the pressure ratio across a duct is usually an input value. For turbine inter-ducts an additional option for the pressure loss calculation is applicable if *Turbine Design* is selected which calculates among other data the downstream duct inlet Mach number. In this case the data for the duct pressure ratio are valid for a reference Mach number. The actual pressure ratio then depends on duct inlet Mach number M calculated by the *Turbine Design* routine.

The calculation employs the loss coefficient ζ which is defined as:

$$\zeta = \left(1 - \frac{P_2}{P_1}\right) \cdot \left(1 + \frac{\gamma - 1}{2} \cdot M_{ref}^2\right)^{\frac{\gamma}{\gamma - 1}} \cdot \frac{1}{M_{ref}^2}$$

The actual pressure ratio for the duct inlet Mach number M is then

$$\frac{P_2}{P_1} = 1 - \zeta \cdot M^2 \cdot \left(1 + \frac{\gamma - 1}{2} \cdot M^2\right)^{-\frac{\gamma}{\gamma - 1}}$$

In off-design calculations **duct pressure losses** are proportional to the relative corrected flow squared.

5.12 Exhaust Duct Pressure Loss

The exhaust duct pressure ratio is an input value during cycle design calculations. During off-design simulations normally the exhaust **duct pressure loss** varies with corrected flow squared.



In more detailed performance simulations the exhaust duct losses can be made a function of the inlet flow angle of the exhaust guide vanes. There are two versions of the loss incidence calculation on offer. Use one of them if the turbine upstream of the exhaust guide vanes operates with constant mechanical spool speed, especially if you need to simulate idle operation accurately.

5.12.1 Calculated Inlet Swirl

With this option the inlet flow angle to the exhaust guide vanes is calculated from the blade exit angle of the preceding turbine rotor, the annulus area and the corrected flow. The blade exit angle is a result from the [Turbine Design](#) calculation for the upstream turbine.

If the flow direction is equal to the minimum loss flow angle α , then the losses are only a function of corrected flow as in any normal duct. However, if the flow direction deviates from the minimum loss direction (incidence $\beta=0$), then there will be additional losses that are described with the incidence pressure loss factor $(P_2/P_1)_i$:

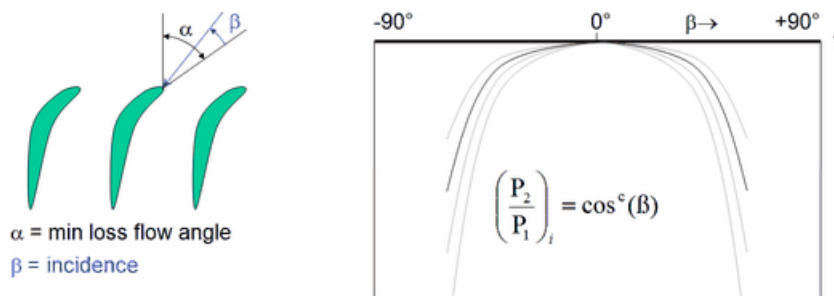

The magnitude of the incidence pressure loss factor can be controlled with the exponent c - the *Incidence Loss Constant* - in the formula.

5.12.2 Swirl from Turbine Map

In a more accurate simulation of the exhaust vane pressure losses the turbine exit angle is not calculated but read from the map of the preceding turbine. Maps with exit angle tables can be created with the help of Smooth T 8.2.

The dependency of the pressure losses from the flow incidence is described with a detailed model that employs different losses for negative and positive incidence angles. Within the positive and negative flat ranges around the minimum loss flow angle the losses due to incidence are negligible. Outside the flat ranges the magnitude of the losses are described with the positive respectively negative incidence loss constants (C_{pos} and C_{neg}).

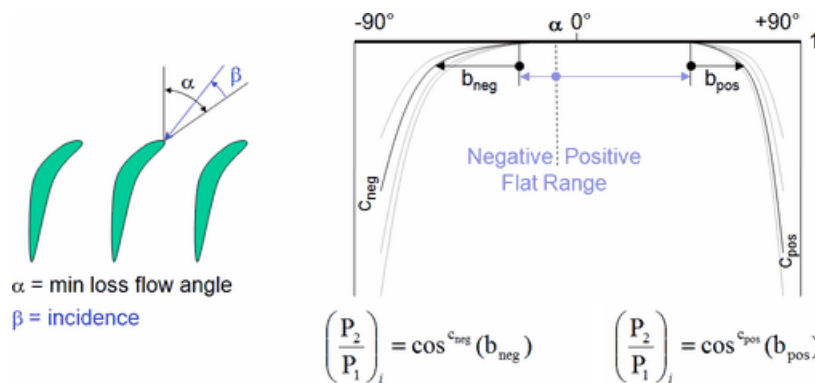

5.13 Mixer

In the mixing calculation the program uses the conservation of energy for finding T_{64} . The mass flow W_{64} is the sum of W_6 and W_{163} . P_{64} is calculated on the basis of conservation of momentum in a constant area duct.

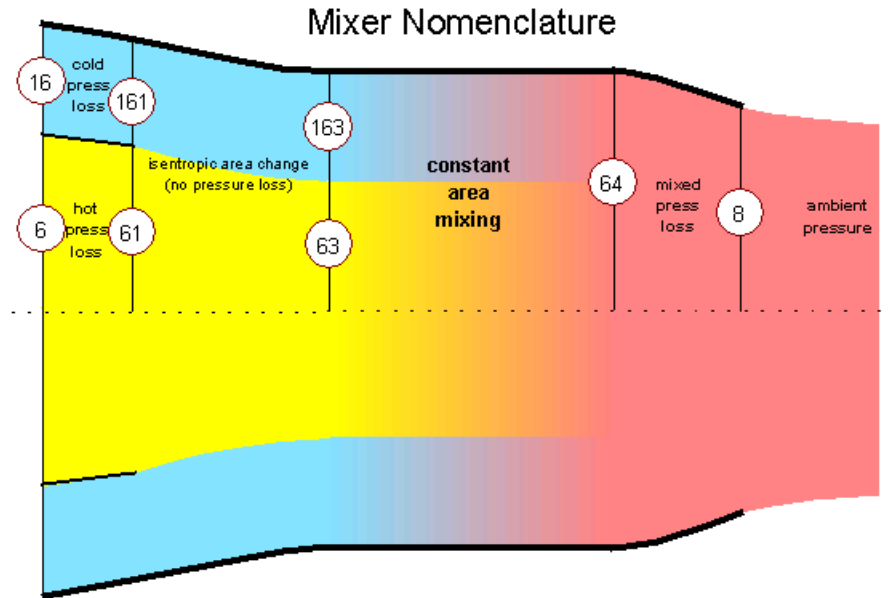

The mixer area A_{64} is equal to the sum of A_{63} and A_{163} . A_{64} can be specified by input or calculated from the mean mixer Mach number M_{64} during design calculations. In off-design the static pressure balance between P_{s63} and P_{s163} is retained. The areas A_{63} and A_{163} are found during the design point calculation from the equal static pressure condition $P_{s163} = P_{s63}$.

In off-design simulations you can apply modifiers to the core (dA_{63}) and bypass (dA_{163}) mixer areas:

$$A_{63} = A_{63,ds} \cdot (1 + dA_{63})$$

$$A_{163} = A_{163,ds} \cdot (1 + dA_{163})$$

$$A_{64} = A_{63} + A_{163}$$

If you want to keep the total mixer area A_{64} constant while modulating A_{63} then define an iteration with dA_{163} as variable and A_{64} as target.

The hot stream mixer pressure ratio P_{63}/P_6 is assumed to vary with the core exit corrected flow in off-design simulations. The cold stream mixer pressure ratio P_{163}/P_{16} is dependent from the bypass exit corrected flow in off-design. Analogously the mixed stream pressure ratio depends on the total corrected flow downstream of the mixer.

Note that the utility GasTurb Details 6 which comes with the GasTurb 13 package is excellently suited to study the effects of mixing two streams.

5.14 Reheat (Afterburner)

A reheated cycle is calculated in off-design simulations in two steps:

- First, the program finds the dry operating point which is specified by the selection on the *Basic* input page in the line *ZXN given (1) or ZT4 given (2)*. This calculation step yields the inlet conditions to the reheat system.
- Second the necessary reheat fuel flow for the desired *Reheat Exit Temperature* will be calculated. A new nozzle throat area follows from the revised nozzle inlet conditions.



There are thus two nozzle throat areas in a reheated cycle calculation: One is the *Equivalent Dry Nozzle Area*, which is connected with the turbomachinery operating conditions. The other one is the actual nozzle (throat) area.

Note that all the **limiters** act on the operating point of the basic engine (i.e. the turbomachinery). Thus, if you employ a thrust limiter while reheat is on, then this will change the engine spool speed in such a way that you get the desired thrust while the reheat exit temperature remains unchanged. However, you may want that the turbomachines are running at full speed and the thrust should be achieved by adjusting the *Reheat Exit Temperature*. In this case you must not use thrust as a limiter, you need to define an iteration with *Reheat Exit Temperature* as a variable and the desired thrust as iteration target.

5.14.1 Reheat Efficiency

Basically, the same algorithm is used for reheat efficiency as for the **efficiency of combustors**.

However, since the efficiency of afterburners is much lower than that of combustors, the numbers to be used for the part load constant will be different.

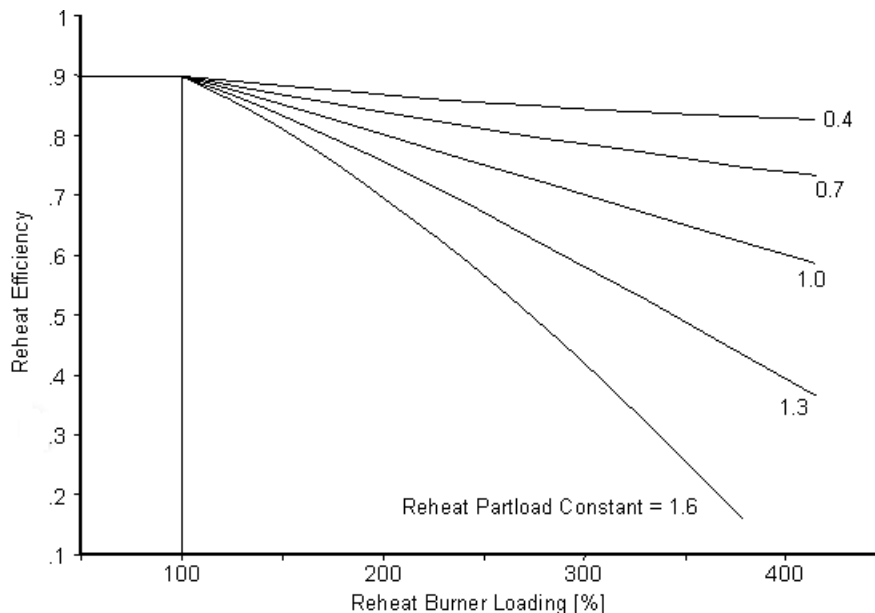

If this simulation methodology is not appropriate for your type of afterburner then you can employ **Composed Values** with a **General Table** to calculate reheat efficiency as a function of fuel-air-ratio and pressure. Iterate *Reheat Design Efficiency* such that the calculated reheat efficiency is equal to the composed value. Note that during off-design simulations the *Reheat Design Efficiency* is selectable as iteration variable only after it has been **made an input quantity**.

5.14.2 Reheat Pressure Loss

Reheat systems (Afterburners) of aircraft engines are modeled in GasTurb 13 as ducts with constant area. Selecting *Reheat* during cycle design will automatically make the area of the downstream **Thermodynamic Station** the same as the inlet area which is calculated from the *Reheat Design Inlet Mach No.* When you select the *Special Reheat Calc* methodology then you can account for tapered jet pipes by setting the ratio of *Effective Burning Area / A61* (respectively *Effective Burning Area / A64*) to a value less than one. The *Effective Burning Area* is employed for calculating the loss in total pressure due to heat addition. This loss is sometimes called a fundamental pressure loss, while the line connecting different amounts of heat addition plotted in a temperature-entropy diagram is called a *Rayleigh Line*. No more heat can be added after sonic velocity at the duct exit is reached.

In the afterburner simulation the heat addition pressure loss is calculated as described above. Note that high afterburner inlet Mach numbers which are caused by small *Effective Burning Areas* cause significant total pressure losses. Use GasTurb Details 6 to get a feeling for the magnitude of the numbers.

5.15 Nozzle

5.15.1 Convergent Nozzle

The convergent nozzle calculation is fairly simple. First an isentropic expansion to ambient pressure is assumed. If the nozzle exit Mach number is subsonic, then the static conditions in the nozzle exit plane have already been found. Otherwise the Mach number is set to 1.0 and for this condition new values for T_{s8} and P_{s8} are calculated. The effective nozzle area is found from

$$A_{eff,8} = \frac{W_8 \cdot R \cdot T_{s,8}}{P_{s,8} \cdot V_8}$$

The correlation between the effective flow area $A_{eff,8}$ and the geometric nozzle area A_8 is described by the nozzle discharge coefficient $C_{D8} = A_{eff,8}/A_8$. The magnitude of this coefficient depends on the nozzle petal angle α and the nozzle pressure ratio P/P_{s8} .

If the *Standard Nozzle Calculation* is selected, then the discharge coefficient of convergent nozzle will be taken from the empirical correlation shown in the figure below:

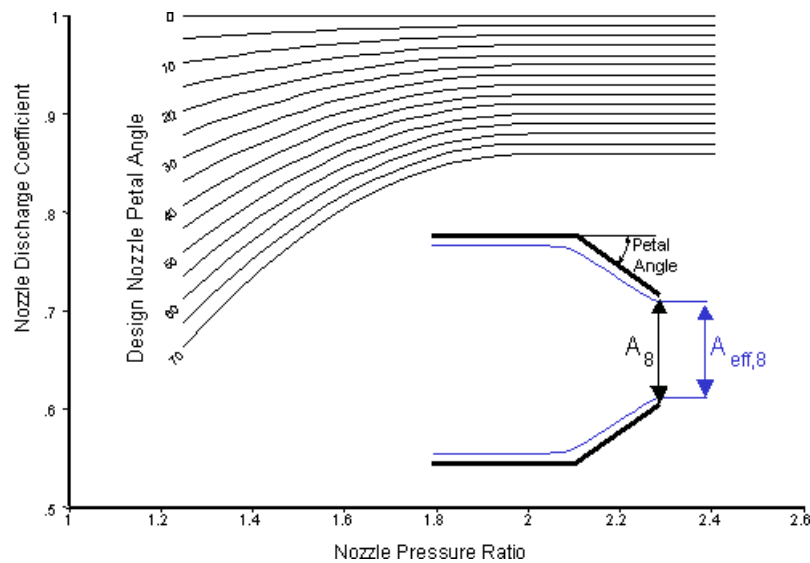

5.15.2 Convergent-Divergent Nozzle

For the convergent-divergent nozzle the calculation from the inlet to the throat (station 8) is usually an expansion to sonic conditions. From station 8 to station 9 the flow is expanded supersonically according to the prescribed area ratio A_9/A_8 . If the nozzle exit static pressure P_{s9} comes out higher than ambient pressure then the solution has been found and the calculation is finished.

Otherwise, a vertical shock is calculated with upstream Mach number M_9 . If the static pressure downstream of the shock is lower than ambient pressure then there will be a shock inside the divergent part of the nozzle. If not, then the pressure term in the thrust formula is negative, however the result with P_{s9} less than P_{amb} is valid.



At very low nozzle pressure ratios the flow will be completely subsonic. In such a case the nozzle behaves like a venturi.

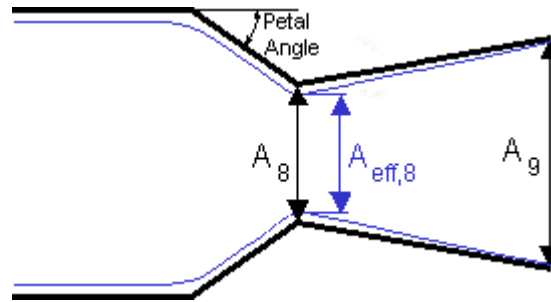

The nozzle discharge coefficient $C_{D8} = A_{eff,8}/A_8$ of a convergent nozzle depends only on the petal angle α (measured in $^\circ$) of the convergent part of the nozzle:

$$C_{D8} = 1 - 0.002 \cdot \alpha$$

In contrary to the discharge coefficient of a convergent nozzle it is independent from the nozzle pressure ratio.

For the cycle design point the primary petal angle is an input quantity if the *Standard Nozzle Calculation* methodology is selected. If the engine has got a reheat system (an afterburner), then the design petal angle is valid for the *equivalent dry nozzle area*. The true petal angle will be smaller because the nozzle throat area is bigger when reheat is lit.

In many engines featuring convergent-divergent nozzles of circular design, the theoretically computable over-expansion does not occur in practice. The reason for this *Over-Expansion Limit* is the gap between the master and the slave petals in the divergent part of the nozzle, which opens when the static pressure surrounding the nozzle is higher than the inside pressure. The slave petals then detach from the master petals and thus open a path for ambient air. This reduces the effective nozzle exit area A_9 and the effective area ratio A_9/A_8 gets smaller than the geometric area ratio.

If *Limit Over-Expansion* is selected during cycle design, the empirical correlation shown below is employed to determine the highest effective area ratio which occurs in a real nozzle with the above described effect. The geometric nozzle area ratio is compared with this value, before the calculation of the convergent-divergent nozzle flow begins. If the geometric area ratio is bigger than the maximum effective area ratio, then the value from the figure will be employed in the calculation, effectively limiting the over expansion. With this procedure, values for the static pressure at the nozzle exit are never lower than 90% of ambient pressure.

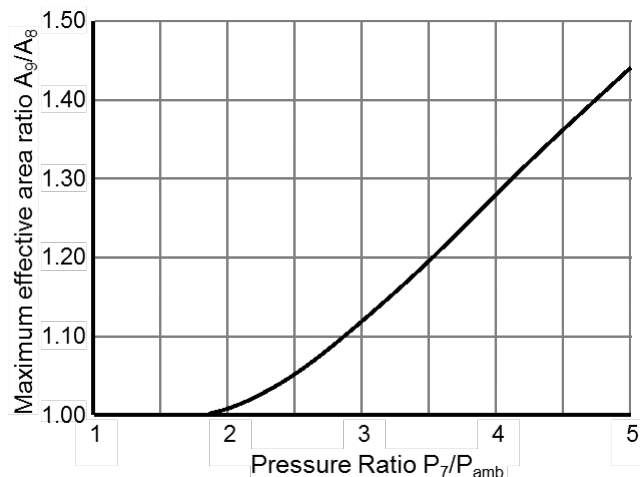

5.15.3 Thrust Coefficient

The thrust coefficient is a factor on the velocity term of the gross thrust. The net thrust of an unmixed flow turbofan, for example, is calculated as

$$F_N = W_8 \cdot V_8 \cdot C_{FG,8} + A_8 \cdot (P_{s,8} - P_{amb}) + W_{18} \cdot V_{18} \cdot C_{FG,18} + A_{18} \cdot (P_{s,18} - P_{amb}) - W_2 \cdot V_0$$

In this formula $C_{FG,8}$ is the thrust coefficient of the core nozzle and $C_{FG,18}$ is the thrust coefficient of the bypass nozzle.

Do not mix up these two thrust coefficients with the ideal thrust coefficient $C_{FG,id}$ of a convergent-divergent nozzle which is defined as

$$C_{FG,id} = \frac{F_G}{F_{G,id}}$$

The term $F_{G,id}$ is the gross thrust for a full expansion to ambient pressure while F_G is the gross thrust of the convergent-divergent nozzle for an expansion to the nozzle exit area A_9 .

5.16 Thermodynamic Stations

The *Thermodynamic Stations* are marked for each engine configuration in the respective *Nomenclature* window. The cycle calculation yields at these locations the mass flow, the total pressure and the total temperature. The static pressures and temperatures are not explicitly needed and only of secondary importance for the evaluation of the thermodynamic cycle with the exception of the nozzle and the exhaust system.

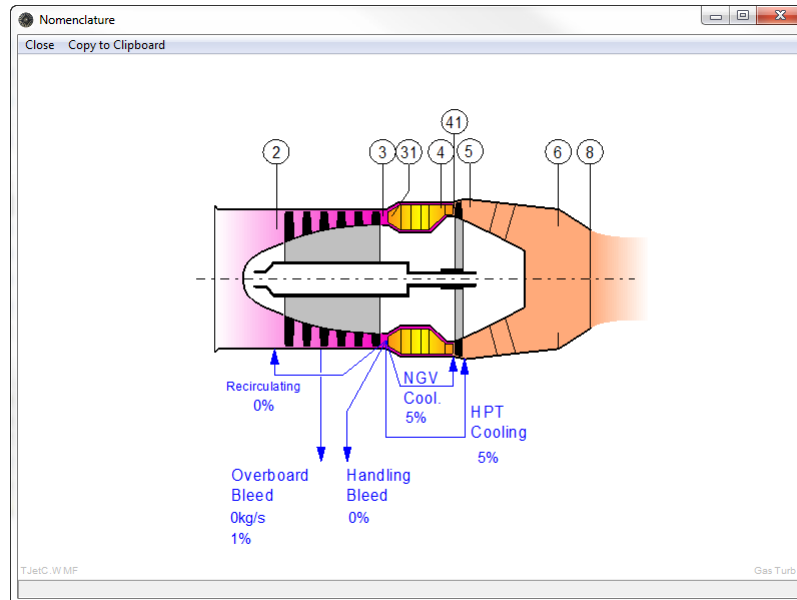

However, for determining the size of the flow channel the flow velocity and the density are needed and - together with other properties - make in GasTurb 13 a *Thermodynamic Station*. Only stations that are relevant for finding the dimensions of the engine are considered as full thermodynamic stations. For example, the stations 31 and 41 in the figure above are not employed for calculating the dimensions and you therefore will not find them in the list of *Thermodynamic Stations* of the TURBOJET.



During cycle design for most of the *Thermodynamic Stations* you can either specify on the *Stations* input page the Mach number or the flow area. One of these two quantities must be zero, the other positive; supersonic Mach numbers are not permitted.

If you select [Compressor Design](#) then the properties of the inlet station of the compressor will be calculated, while selecting [Turbine Design](#) yields those of the exit station.

Turbine Design implies a velocity diagram analysis in which the mass flow considered does not include the rotor cooling air because this flow does not contribute to the work done. Note that the flow area of the turbine exit *Thermodynamic Station* is calculated from the axial Mach number which was found from the velocity triangle analysis and the mass flow and the total temperature after adding the rotor cooling air to the mainstream.

Since the exit flow, its direction and the temperature at the turbine exit are different, the turbine exit area found from the velocity triangle analysis is not the same as the area of the turbine exit *Thermodynamic Station*.

Any afterburner of an aircraft engine is designed as constant area duct and thus the exit station has the same area as the inlet to the afterburner.

5.17 Secondary Air System

For cycle design calculations you will find all input data on the *Secondary Air System* page except the absolute amount of the overboard bleed (customer bleed) which is on the *Basic* data page.

During off-design simulations you normally can only modify the absolute and relative amounts of the overboard bleed. You can, however, make the other air system properties visible by clicking the  (*Visibility*) in the *Extras* button group.

The term [Rel.Enthalpy](#) describes how much work is done on an interstage bleed air relative to the total compression work of the compressor from which the bleed is taken.

5.18 Propeller

From GasTurb 13 you will get information about an [ideal propeller](#) and a [real propeller](#). For the real propeller you can use a map and thus accurately describe the behavior of this device. The terminology used is taken from [Reference 17](#).

5.18.1 Ideal Propeller

Some interesting correlations for the ideal propeller can be derived from one dimensional theory. It allows calculation of the ideal propeller efficiency which cannot be exceeded by the efficiency of a real propeller. The ideal thrust coefficient is a measure of thrust per propeller disk area. Another propeller performance indicator is the ideal power coefficient.

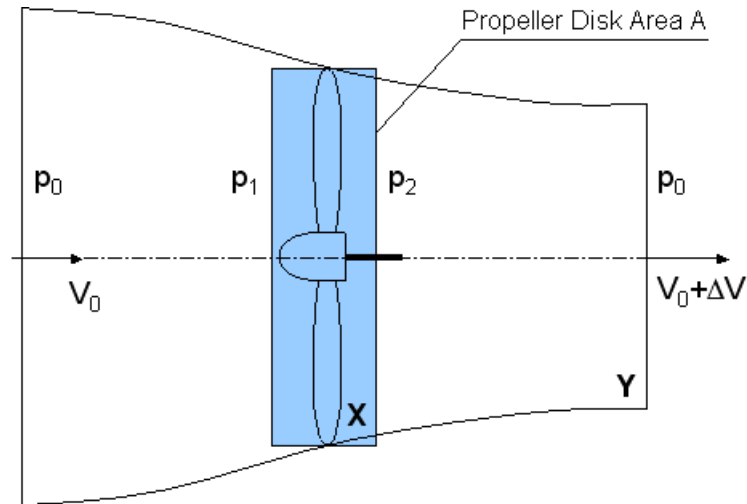

For finding the correlations for the ideal performance of a propeller we consider the small control volume X which surrounds an "actuator disk" (with area A). There is a sudden rise in pressure, but no change in the local velocity. The change in pressure follows from Bernoulli's formula:

$$p_1 - p_2 = \rho \cdot \Delta V \cdot \left(V_0 + \frac{\Delta V}{2} \right)$$

The thrust of the propeller is

$$F_{id} = A \cdot (p_2 - p_1) = A \cdot \rho \cdot \Delta V \cdot \left(V_0 + \frac{\Delta V}{2} \right)$$

We can also apply the conservation of momentum to the large control volume Y, and then we get a second expression for the ideal propeller thrust:

$$F_{id} = A \cdot \rho \cdot V_p \cdot \Delta V$$

Combining both formulas for the thrust results in

$$V_p = V_0 + \frac{\Delta V}{2}$$

That means that far downstream of the propeller the jet velocity V_{id} is twice the velocity in the propeller plane. The *Ideal Propeller Efficiency* is

$$\eta_{P,id} = \frac{F_{id} \cdot V_0}{A \cdot V_p \cdot (p_2 - p_1)}$$

which can be transformed to

$$\eta_{P,id} = \frac{2}{1 + V_{id}/V_0}$$

The *Ideal Thrust Coefficient* is a measure of thrust per unit of propeller disk area:

$$C_{F,id} = \frac{F_{id}}{A \cdot \rho \cdot V_0^2 / 2}$$

Another propeller performance indicator is the *Ideal Power Coefficient*, which is defined as

$$C_{PW,id} = \frac{A \cdot V_p \cdot (p_2 - p_1)}{A \cdot \rho \cdot V_0^3 / 2}$$



5.18.2 Real Propeller

In reality there are always losses like frictional drag on the blades, uneven velocity distribution over the propeller disk area, swirl in the slip stream etc. Therefore, the performance of a real propeller will always be worse than that of an [ideal propeller](#). Traditionally the performance of real propellers is described by some dimensionless parameters. The thrust coefficient C_F relates the thrust to ambient air density, propeller speed and diameter.

$$C_F = \frac{F}{\rho \cdot n^2 \cdot d^4}$$

with n = rotational speed (in revolutions per second) and d = propeller diameter.

The *Advance Ratio* J is a measure of the forward movement of the propeller per revolution:

$$J = \frac{V_0}{n \cdot d}$$

The *Power Coefficient* C_{PW} of a real propeller is defined as

$$C_{PW} = \frac{PW_{SD}}{\rho \cdot n^3 \cdot d^5}$$

and the *Propeller Efficiency* is

$$\eta_P = \frac{F \cdot V_0}{PW_{SD}} = \frac{C_F \cdot J}{C_{PW}}$$

For static conditions ($J=0$) this definition leads to efficiency = 0. In this case the following definition of the propeller quality is appropriate:

$$\eta_{P,static} = \sqrt{\frac{2}{\pi}} \cdot \frac{C_F^{3/2}}{C_{PW}}$$

From the cycle calculation the shaft power delivered, PW_{SD} , is known and the power coefficient of the propeller can be calculated easily. The static thrust follows from

$$F_{static} = \left(\eta_{P,static} \cdot \sqrt{\frac{\pi}{2}} \cdot C_{PW} \right)^{2/3} \cdot \rho \cdot n^2 \cdot d^4$$

The ratio of thrust coefficient to power coefficient C_F/C_{PW} is another measure of static propeller efficiency. From this ratio one can also calculate the static thrust:

$$F_{static} = \frac{C_F}{C_{PW}} \cdot \frac{PW_{SD}}{n \cdot d}$$

When you do not use a [propeller map](#), then the input value for the propeller efficiency is interpreted as static efficiency if the flight velocity is zero.

5.19 Component Maps

5.19.1 Intake Map

An *Intake Map* consists of a single table with the [relative corrected speed](#) of the first compressor as the argument and flight Mach number as the parameter. During cycle design calculations the relative corrected speed of the first compressor is equal to 1.0 by definition.

On principle the corrected flow of the first compressor would be a better parameter. However, the use of corrected speed makes the calculation simpler and does not affect the accuracy of the result very much.

The file with an intake map must begin with a single line header which commences with "99". A map title may follow after at least one "blank" on the same line. An example is given with the file Intake01.map which is delivered together with the program.

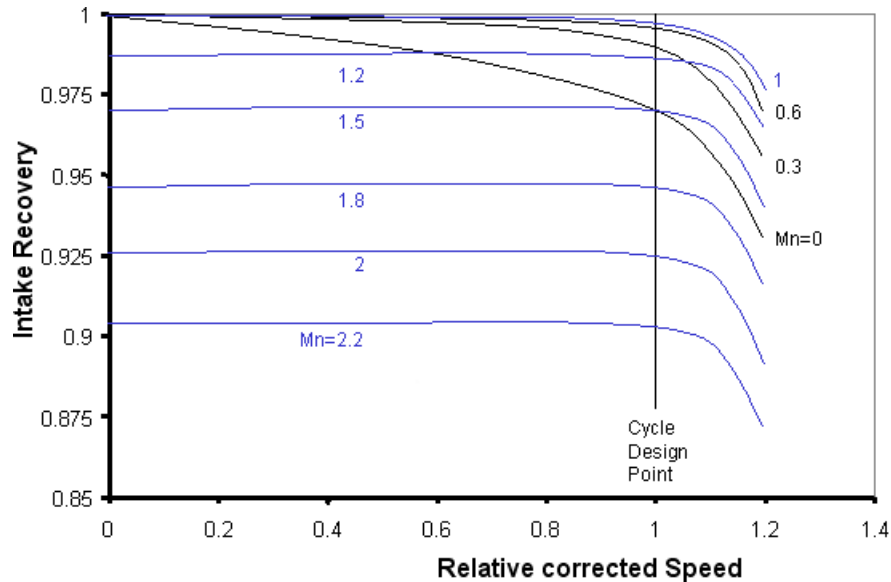

5.19.2 Compressor Maps

5.19.2.1 Compressor Map

A compressor map shows pressure ratio over corrected flow as a function of relative corrected spool speed with contour lines of constant isentropic efficiency. Fan and booster maps employed with the TWO SPOOL MIXED FLOW TURBOFAN configuration are special cases.

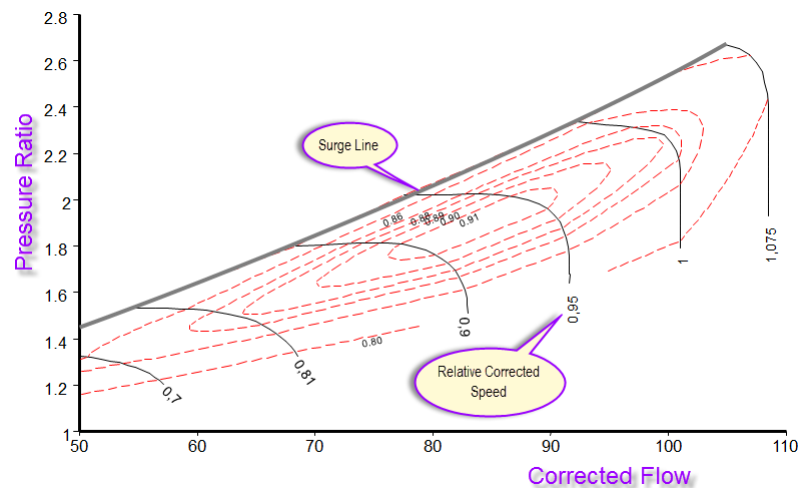

For details about the data input of a compressor map have a look at the section [Compressor Map format](#).

Compressor maps (and also turbine maps) are shown by GasTurb 13 without Reynolds correction and also without map modifiers applied. The operating points shown in the graphic are the values read from the map tables, before any map modifiers or Reynolds corrections are applied. Therefore the numerical values found on the output summary page - which show the Reynolds-corrected data and with modifiers applied - are not necessarily in line with the picture of the map.



When switching from cycle design to off-design simulations then the map is scaled in such a way that it is in line with the cycle design point. During off-design simulations the map is read with known values of relative corrected spool speed and beta. Corrections for Reynolds number effects, variable geometry settings and map modifiers are applied before using pressure ratio, efficiency and corrected flow in the cycle calculation.

5.19.2.2 Fan Map

Low and high bypass turbofan engines show significant differences in fan and booster geometry as can be seen in the figure below. These differences can be accounted for with adequate simulation models. For the TWO SPOOL MIXED FLOW TURBOFAN configuration there are three options for the fan and booster performance simulation.

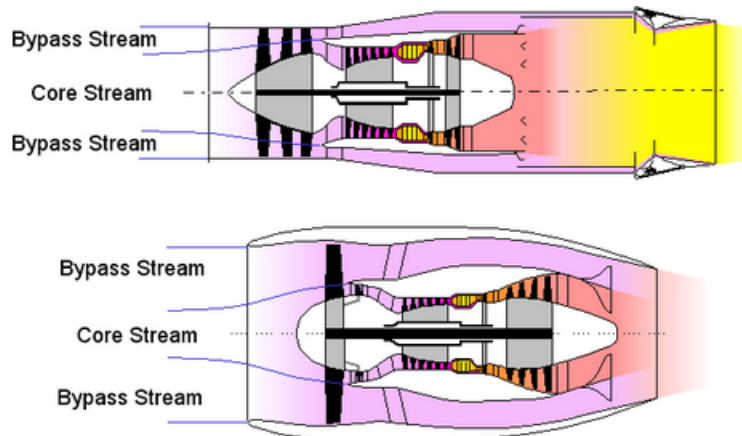

Select between the fan and booster simulation options with the *Booster Map Type* indicator (found in *Design Point Input, Basic Data*):

0	<p>No special booster map, the inner map data will be scaled from the outer map.</p> <p>This option is most suited for high bypass engines without booster stages and for low bypass engines as shown in the upper part of the figure</p>
1	<p>Independent booster map (only corrected speed common).</p> <p>This option should be chosen for high bypass engines with booster stages as shown in the lower part of the figure.</p>
2	<p>Split map: common corrected speed and corrected flow.</p> <p>Use this option with low bypass turbofans for more accurate off-design simulations</p>

With *Booster Map Type=0* a conventional compressor map is employed. The corrected flow read from this map is the total engine inlet corrected flow. Pressure ratio and efficiency tabulated in the map are those of the bypass stream.

The pressure ratio of the core stream is calculated as:



$$\left(\frac{P}{P}\right)_{core} = 1 + \left[\left(\frac{P}{P}\right)_{bypass} - 1 \right] \cdot \left\{ \frac{\left(\frac{P}{P}\right)_{core} - 1}{\left(\frac{P}{P}\right)_{bypass} - 1} \right\}_{Design}$$

The efficiency of the core stream is calculated as:

$$\eta_{core} = \eta_{bypass} \cdot \left(\frac{\eta_{core}}{\eta_{bypass}} \right)_{Design}$$

With *Booster Map Type=1* two compressor maps are used: one for the core stream and the other for the bypass stream. These two maps are connected through the corrected spool speed which is obviously the same for both maps when running a simulation. Both maps are read with their own **beta value**. Reading the maps yields two corrected mass flows, two pressure ratios and two efficiencies. Note that the component matching and thus the operating points in both maps are affected by the correlations between corrected flow and corrected speed in each of the maps.

Using *Booster Map Type=2* requires again two maps, one for the core stream and one for the bypass stream. The difference to the previous methodology is that both maps contain the total corrected mass flow. Of course the maps are read during simulations with the same corrected speed value. In contrary to the *Booster Map Type 1* option the two maps are read with the same **beta value**. This yields pressure ratio and efficiency for the core and the bypass stream.

5.19.2.3 Single Stage Fan Map

At high speed the transonic flow field of the outer stream is very different to the subsonic flow field of the core stream. The profile of the outer part of the blade is designed for supersonic flow while the blade region near to the hub is optimized for subsonic flow. The off-design behavior of the bypass part of the fan is very different to that of the core stream.

The most simple way to describe the differences in pressure ratio and efficiency between the core and the bypass stream is the following: The map tables contain values for total mass flow, bypass pressure ratio P_{13}/P_2 and bypass efficiency η_b . The core stream pressure ratio P_{21}/P_2 and the efficiency η_c are derived from the bypass map by applying constant factors:

$$P_{21} / P_2 = 1 + f_{P/P} \cdot (P_{13} / P_2 - 1)$$

$$\eta_c = f_{\eta} \cdot \eta_b$$

Another simple model considers the fan root as part of the booster. Both these methodologies ignore the fact that the bypass ratio is not constant; in fact it varies considerably from idle to maximum thrust and throughout the flight envelope.

A new way of describing the performance of single stage fans is described in Ref. 30. The map describes the overall fan performance. An additional table with core stream efficiency completes the overall map. Core stream pressure ratio is calculated from a fan hub velocity triangle analysis and efficiency. Bypass stream pressure ratio and bypass efficiency are calculated from the overall and the core stream data by taking the actual bypass ratio into account.

The program Smooth C 8.3 makes the generation of core stream efficiency tables easy. The rotor blade exit angle representative for the core stream is used for calculating the work done on the core stream.

The rotor blade exit angle is calculated during cycle design if LPC Design is selected.



There is no dedicated switch in the program to select this methodology. It is applied automatically if a fan map with the additional core efficiency table is loaded and LPC Design has been selected during cycle design.

5.19.2.4 Beta Value

Reading a compressor map with given corrected speed and mass flow leads to problems at high speed because there the speed lines have vertical sections. Reading the map with given pressure ratio can be ambiguous at low corrected speeds. To resolve the map reading problem auxiliary coordinates, the so-called β -lines, are introduced.

The use of β is just a mathematical trick and therefore β has no meaning in terms of physics. Within a map the β -values vary between 0 and 1 in GasTurb 13 and therefore valid off-design results must show β -values between 0 and 1. Note that also in turbine maps β -lines are used.

During off-design iterations the β values are iteration variables.

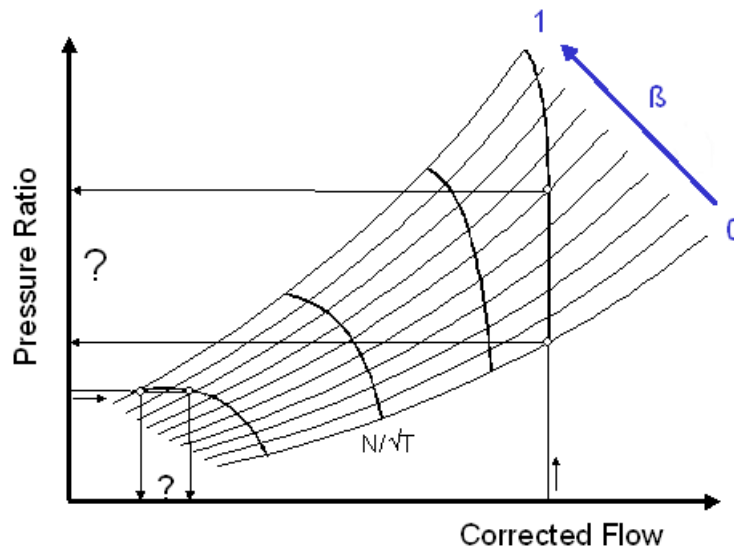

5.19.2.5 Surge Margin

For any operating condition within the flight envelope sufficient surge margin must remain to guarantee the operability of the engine. There are several definitions of surge margin in use, so beware if numbers are quoted:

$$SM_{P/P} = 100 \cdot \frac{(P/P)_{surge\ line}}{(P/P)_{operating\ line}} @\ const\ flow$$

$$SM_{P/P-1} = 100 \cdot \frac{(P/P)_{surge\ line} - (P/P)_{operating\ line}}{(P/P)_{operating\ line} - 1} @\ const\ flow$$

$$SM_{speed} = 100 \cdot \frac{W_{operating\ line} \cdot [(P/P)_{surge\ line} - 1]}{W_{surge\ line} \cdot [(P/P)_{operating\ line} - 1]} @\ const\ speed$$

The first formula is the internationally accepted SAE definition. The second - which is the standard in GasTurb 13 - takes into account that the operating pressure ratio usually does not drop below 1 and the third definition is oriented at a true surge process which happens at constant corrected speed, not at constant corrected flow.

$SM_{P/P}$ can be calculated from $SM_{P/P-1}$ with the help of a composed value. For a turbojet example the composed value definition would be:

$$SM_{PqP} = SM_{HPC} \cdot (1 - 1/P3q2)$$

5.19.3 Turbine Map

Turbine maps in GasTurb 13 come in six different formats, all of them with contour lines of constant isentropic efficiency η :

1. P4/P5 over relative corrected speed N_{corr}
2. P4/P5 over corrected flow W_{corr}
3. P4/P5 over the product of relative corrected speed N_{corr} and corrected flow W_{corr}
4. $\Delta H/T4$ over relative corrected speed N_{corr}
5. $\Delta H/T4$ over corrected flow W_{corr}
6. $\Delta H/T4$ over the product of relative corrected speed N_{corr} and corrected flow W_{corr}

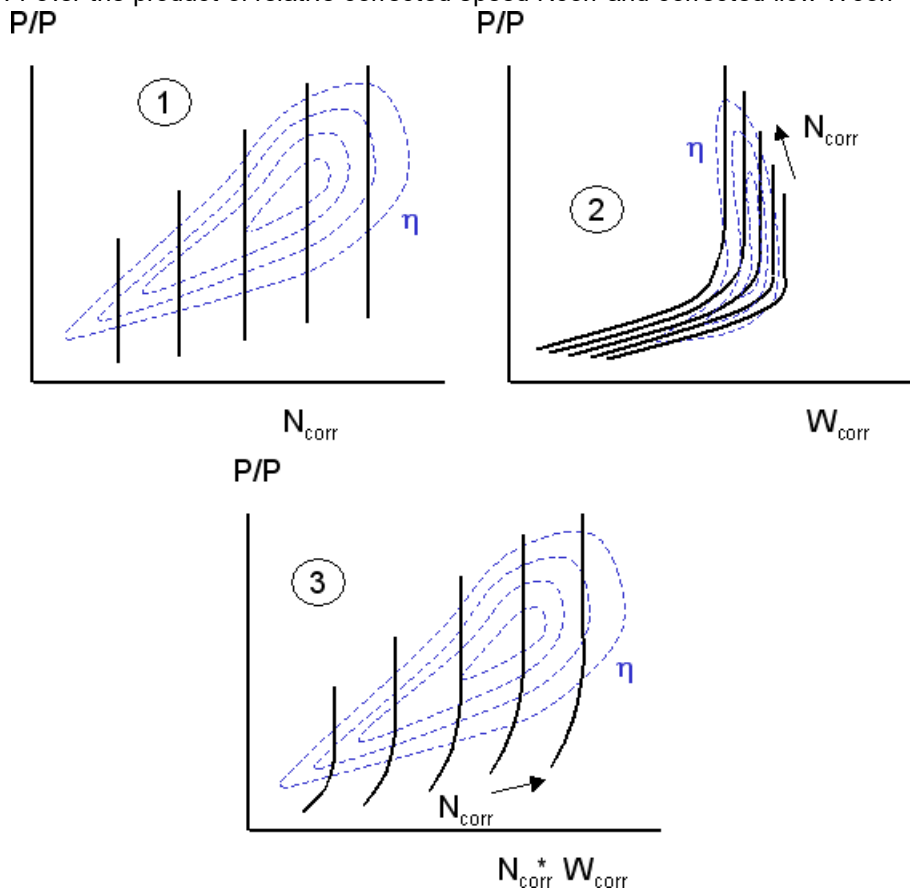

Plotting efficiency contour lines in a turbine map with corrected flow as x-axis (as in the 2nd format) is not practical when the turbine inlet guide vane chokes because then all speed lines collapse in the region of high pressure ratios. Using the product of corrected speed and corrected flow spreads the map nicely and allows to show lines of constant efficiency and operating lines.



Note that GasTurb 13 uses in compressor and turbine maps the relative corrected spool speed, i.e. the corrected spool speed divided by the corrected spool speed at the cycle design point.

Turbine maps (and also compressor maps) are shown by GasTurb 13 without Reynolds correction and also without the map modifiers applied. The operating points shown in the graphic are the values read from the map tables, before any map modifiers or Reynolds corrections are applied. Therefore the numerical values found on the output summary page - which show the Reynolds-corrected data and with modifiers applied - are not necessarily in line with the picture of the map.

When switching from cycle design to off-design simulations then the map is scaled in such a way that it is in line with the cycle design point. During off-design simulations the map is read with known values of relative corrected spool speed and beta. Corrections for Reynolds number effects and map modifiers are applied before using pressure ratio, efficiency and corrected flow in the cycle calculation.

5.19.4 Propeller Map

A propeller map will give you the efficiency as a function of Advance Ratio and Power Coefficient. For static conditions an additional correlation is stored in a separate table as $C_F/C_{PW} = f(C_{PW})$.

The propeller map is difficult to read in the region of low Advance Ratios. There the thrust will be linearly interpolated between the value derived from the propeller efficiency at Advance Ratio = 0.2 and the static thrust.

The propeller efficiency read from the map can be corrected for Mach number effects. Above the critical Mach number efficiency will drop according to

$$\Delta\eta_P = C_{\Delta\eta} \cdot (M - M_{cr})^2$$

If you do not have a map of the propeller which fits to your engine design point, then you can scale the map delivered with the program.

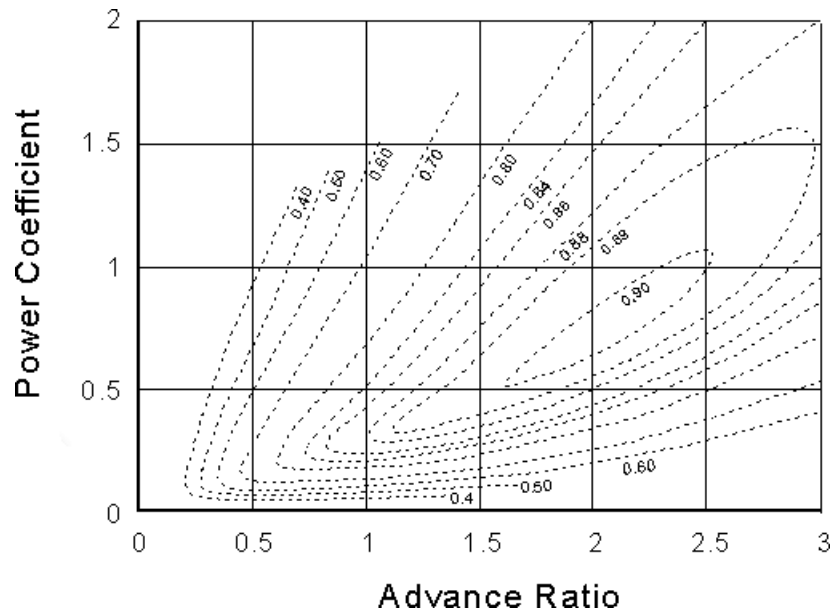

Engine Dimensions





6 Engine Dimensions

6.1 Using a Given Cross Section

If you have a drawing of the engine you want to model, then you can use it as background for the drawing of the GasTurb engine geometry. This is very helpful for designing the flow annulus and the disks.

In the *Background Picture* button group click the *Read* button and load a bitmap of the engine cross section:

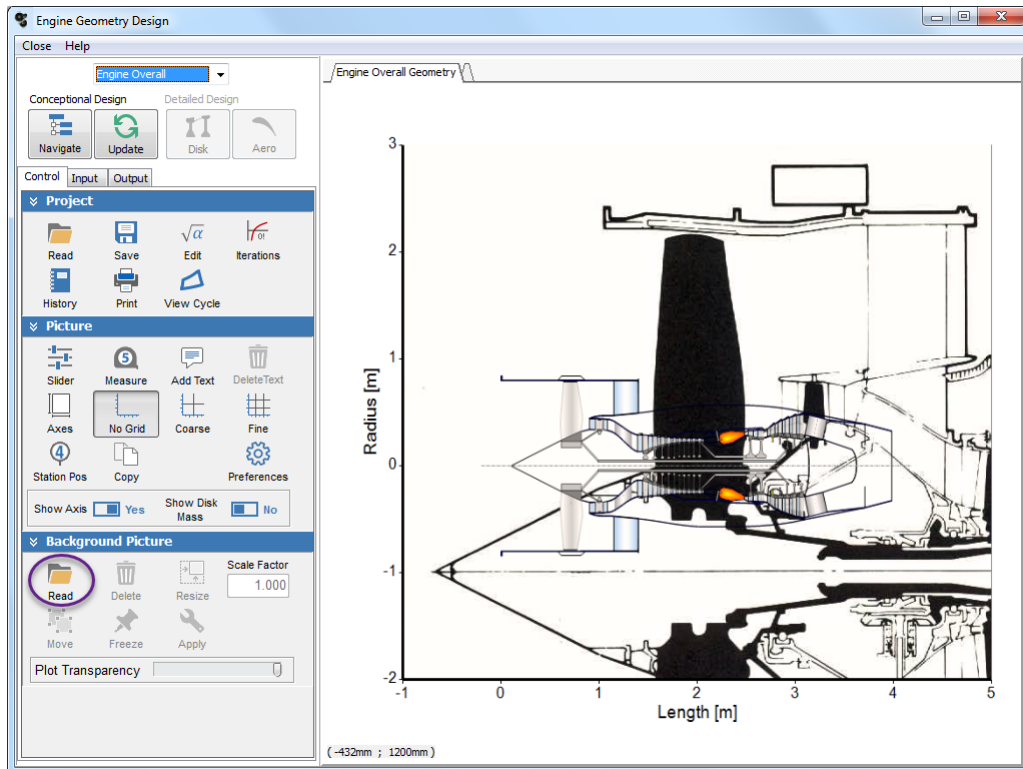

Obviously the bitmap picture of the engine in the first figure is much too big, it needs to be scaled in such a way that it fits to the given scales. Click the *Resize* button, enter a factor in the box below this button and then click *Apply*:

The scaled bitmap will appear somewhere in the picture, certainly not at the right place. Click the *Move* button and then move the background picture with your mouse or with the arrow buttons on your keyboard:

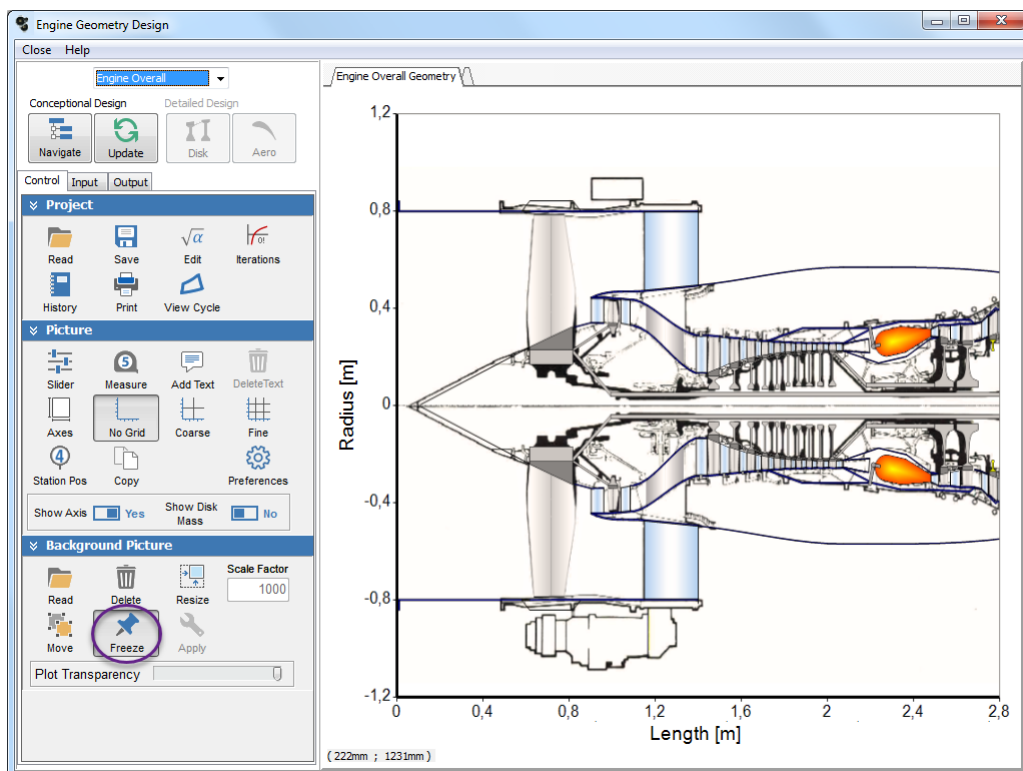
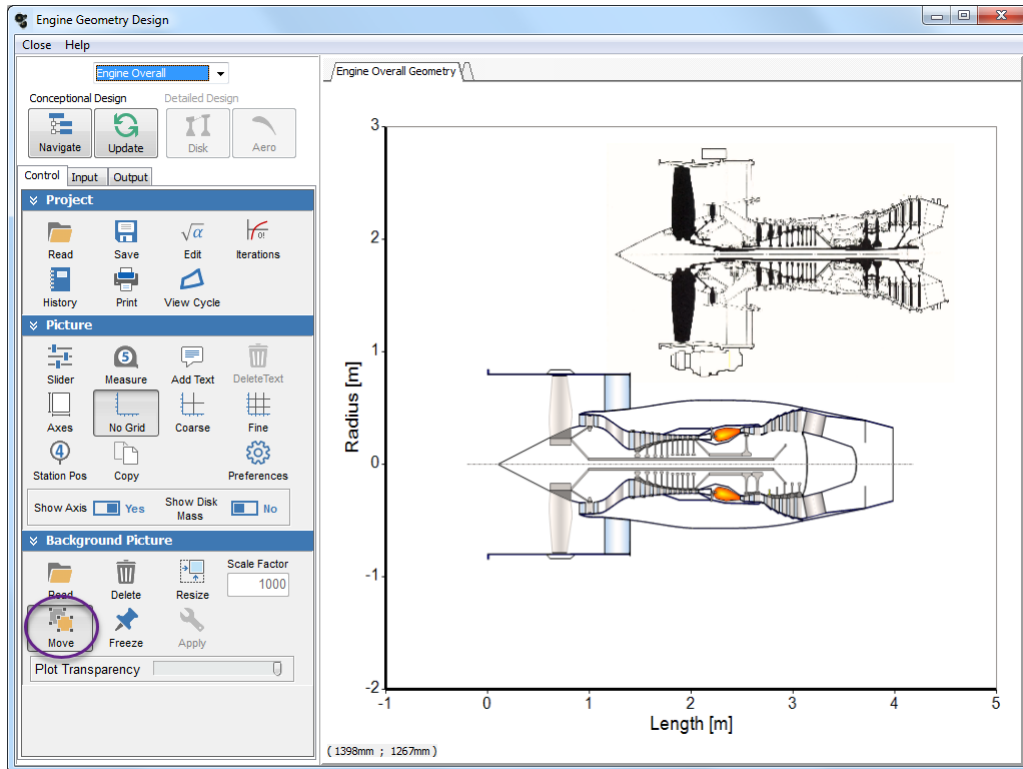

When you are happy with the size and the position of the background picture click the *Freeze* button. After that you can zoom into the picture and see many details.



6.2 Engine Inlet

The dimensions of the engine inlet are derived from the inlet radii of the downstream compressor. The engine inlet is a pipe with constant casing radius; it contains a cone and struts as front bearing support. The struts are positioned upstream of the optional compressor inlet guide vanes which are modeled as part of the compressor. If no struts are needed, then set the relative strut chord to zero.

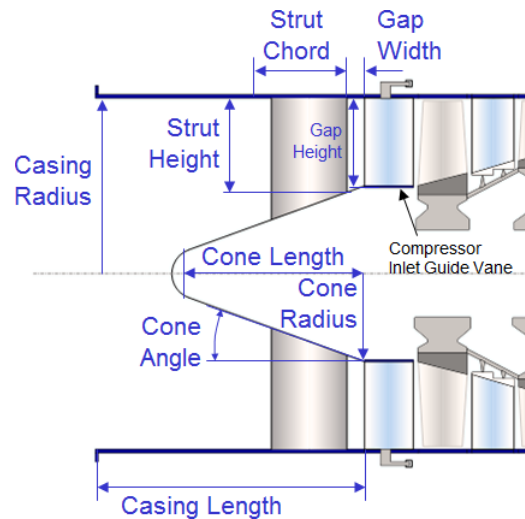

Inlet Geometry Nomenclature

Note that the cone length does not include the front cap. The minimum cone length is equal to the sum of strut chord and gap width. For creating a short cone, use a high value for the cone angle together with a moderate value for the length of the cone.

The mass (weight) of the inlet is composed of the masses of the casing, the struts and the cone.

- Casing mass is the product of casing surface area, mean casing thickness and the density of the casing material.
- Struts are composed from two surfaces with the same thickness and the same material as the casing.
- The cone is modeled as a shell with the same thickness and material as the casing.

For getting a reasonable inlet mass, select a representative material thickness which takes into account flanges and any non axis-symmetric features which might exist. Note that no front engine bearing is included in the inlet mass, even if the inlet has got struts which could support a bearing housing.

6.3 Fan

Single stage fans and multiple stage fans are different with respect to the position of the exit guide vane. The exit guide vanes of a multi-stage fan are upstream of the splitter while those from a single stage fan are downstream of the splitter.



6.3.1 Fan and Booster Design Example

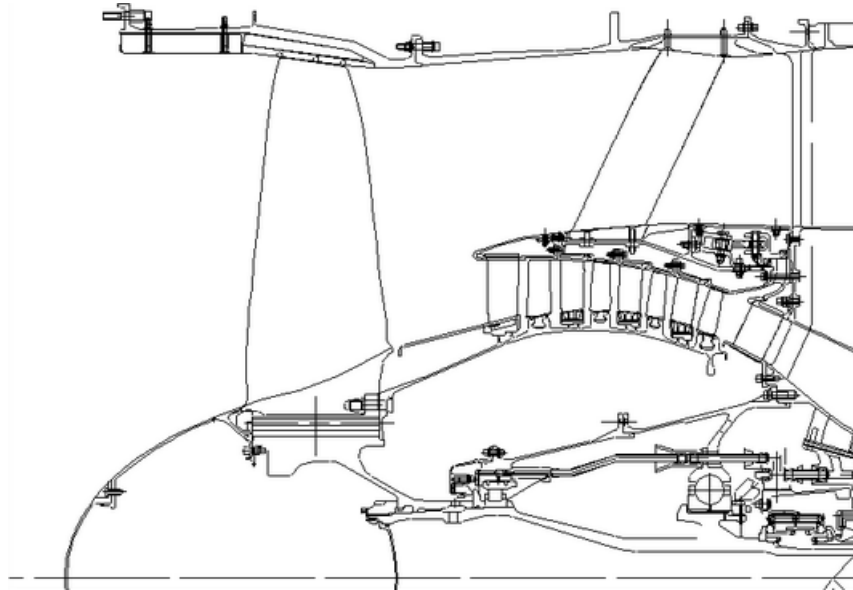

6.4 Compressor

6.4.1 Axial Compressor

For drawing the engine cross section only few non-dimensional data like hub-tip ratios and blade aspect ratios are required. Inlet hub-tip radius ratio is the same as the input value for the [Compressor Design](#) option. Therefore - while *Compressor Design* is selected as part of the cycle calculation - the *Inlet Radius Ratio* input is disabled.

The dimensions of the axial compressor flow annulus are calculated stage by stage from the inlet to the exit thermodynamic station. From the flow area at the inlet station and the inlet radius ratio the inner and outer radii at the compressor inlet are found. Compressors with constant hub, mean and tip diameters can be selected with corresponding values for the *Annulus Shape Descriptor* (a number between zero and one). Stage pressure and temperature ratios are then calculated postulating equal aerodynamic loading $\Delta h/U^2$ for each stage and employing the polytropic efficiency of the compressor in total. The axial Mach number at any intermediate position is interpolated linearly from the Mach number at the compressor inlet station and the exit Mach number M_{ex} . With these assumptions the stage inlet and exit flow areas as well as the blade and vane spans are found.

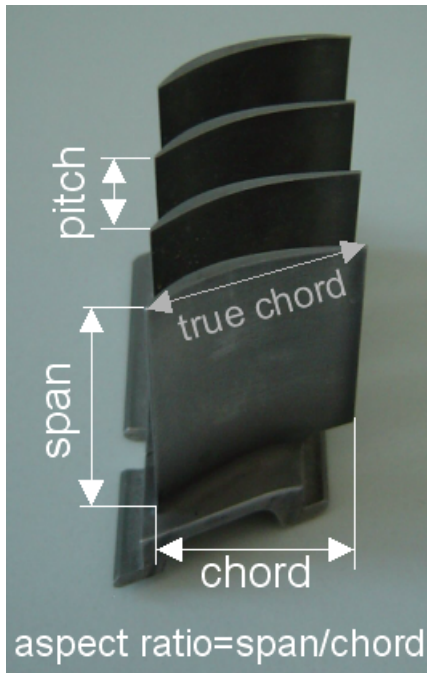

First and last stage aspect ratios are input data. The aspect ratio of intermediate stages is linearly interpolated from these two values. From the aspect ratio the chord length in axial direction can be calculated for all blades and vanes. The gap between blades and vanes is a fraction of the chord of the first rotor blade. Blade and vane numbers are calculated from the given Pitch/Chord Ratio. Note that instead of the true blade respectively vane chord only its axial component is employed in the definitions of Aspect Ratio, Pitch/Chord and Gap/Chord ratios.

Alternatively to the Annulus Shape Descriptor, the annulus geometry can be specified with a Bézier shape. The Bézier can be used to prescribe either hub, mean or tip diameter curves. The remaining two curves and thus the flow annulus are then calculated based on the same assumptions as described above.

From these assumptions results the Conceptual Design of the compressor, including its length. The overall length of the compressor is the sum of all chords and gaps; it does not include the exit diffuser. The design can be investigated in

more detail with the aerodynamic design functionality, which calculates a preliminary compressor design stage by stage and does not rely on the above assumptions.

Once the Aero Design has been calculated, the Geometry from buttons can be used to choose whether Aero Design or Conceptual Design shall be included in the engine preliminary design.

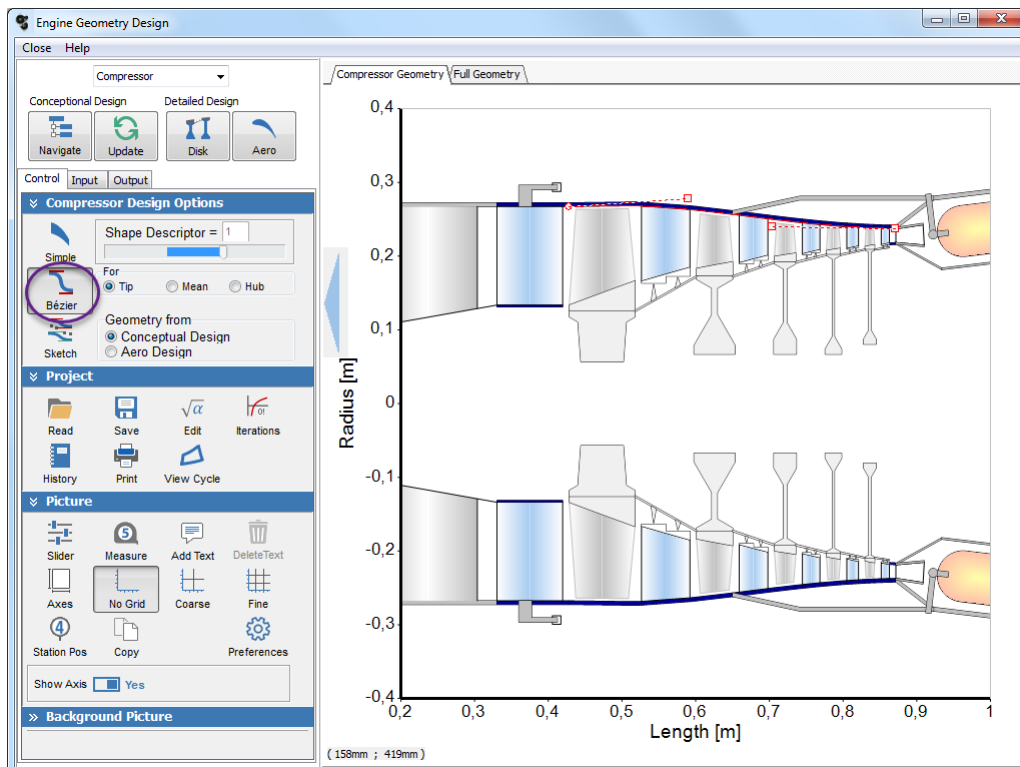

The Sketch option for annulus definition can be used to prescribe the compressor cross section in detail, including both hub and tip radii as well as aspect ratios and gap to chord ratios. It is primarily intended for capturing and recalculating the geometry of known compressors.

If the compressor is followed by a burner, then downstream of the exit guide vane a diffuser decelerates the flow from the compressor exit Mach number M_{ex} to the Mach number at station 3

(burner inlet). The Mach number M_{ex} is calculated from the conditions at station 3 and the diffuser area ratio assuming 2% total pressure loss in the diffuser. The length of the exit diffuser is calculated assuming seven degrees wall angle.

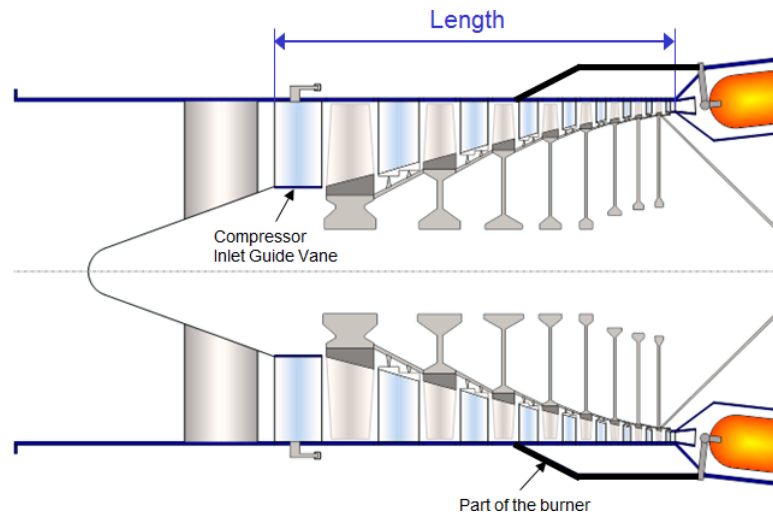

The mass (weight) of the compressor is composed of the following elements:

- The inner and outer casing masses which are the product of casing surface area, mean casing thickness and the density of the casing material.
- Inlet guide vane mass (if there are any IGV's)
- As part of the [disk stress calculation](#) the rotating mass is determined
- The vane mass, which consists of the airfoils and inner vane platforms. Vanes are made of the same material as blades. The mass of a variable guide vane is calculated as twice the mass of a fixed position vane.
- Finally, the mass of the exit diffuser

For getting a reasonable compressor mass result, select representative casing material thickness which takes into account flanges, inter-stage bleed air offtakes and any non axis-symmetric features which might exist.

6.4.1.1 HP Compressor Design Example

This compressor shows on the front stages variable guide vanes and a double outer casing. Inter-stage bleed air offtakes are located after the third and fourth stages.

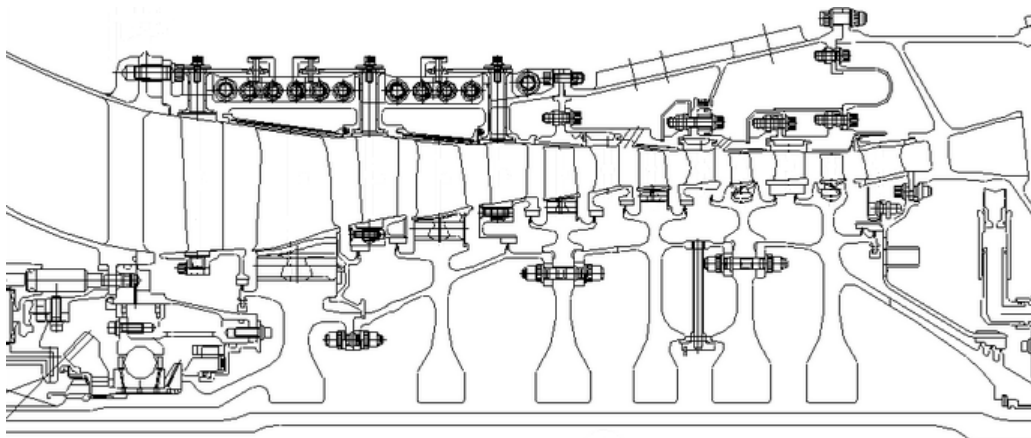



6.4.1.2 Aerodynamic Design

GasTurb 13 has the capability to conduct a detailed stage by stage design calculation of multistage axial compressors. This design calculation is based on a one-dimensional mean line flow analysis that calculates the aerodynamic and thermodynamic properties between each blade row (rotor or stator) of the compressor at the mean radius. These properties are calculated from design variables, design parameters, and loss assumptions. The design parameters are either given as additional input by the user or, where possible, are derived from the cycle data and the annulus shape as defined in the conceptual design window. This way, the input by the user is minimized and the detailed compressor design is consistent with the cycle and the engine geometry. The table below shows the input from cycle and engine geometry. The losses that are used during the design calculation are either prescribed directly by the user, or are calculated with a loss model, which requires further input.

<i>Pressure Ratio</i>	From Cycle
<i>Inlet Mass Flow</i>	
<i>Design Speed</i>	
<i>Inlet Pressure, Inlet Temperature, Water/Air Ratio</i>	
<i>Inlet Area and Exit Area</i>	
<i>Number of Stages</i>	From Conceptual Design
<i>Annulus Shape, Compressor Length</i>	
<i>Row Inlet and Exit Axial Positions</i>	

When the design calculation is performed with the design variables, design parameters, and loss assumptions, the compressor is calculated subsequently stage by stage with the output of one stage being the input for the following stage. Ultimately, the properties at the last stage exit, and therefore at the compressor exit, are calculated. The calculated total pressure at the exit is the same as the total pressure defined by the cycle because the cycle compressor pressure ratio is an input for the design calculation and achieved by automatic adjustment of the stage loading. However, the calculated total temperature at the compressor exit is different because it is calculated by the loss assumptions rather than the cycle compressor efficiency. If desired, the user can adjust the losses in this design calculation so that the mean line flow analysis leads to the same compressor efficiency as defined in the cycle. Alternatively, the compressor efficiency calculated by the mean line flow analysis can be fed back to the cycle. Both adjustments can be accomplished with the iteration feature in GasTurb 13.

▼ Input Variables and Parameters

The compressor design begins with the creation of the mean line velocity triangles for each stage. A velocity triangle describes the flow velocity and direction at a certain point. It comprises velocity vectors of the flow in the absolute reference frame V , the tangential velocity of the rotating component U , and the resulting flow in the relative reference frame of the rotating component W . It also includes the angles of V and W measured relative to the axial direction (α, β) or relative to the rotational direction (α^*, β^*). In GasTurb 13 both conventions can be selected. If the angles are measured relative to the axial direction, the angles in the direction of components rotation are positive. If the angles are measured relative to the rotational direction, the angles are positive in the direction of the flow.

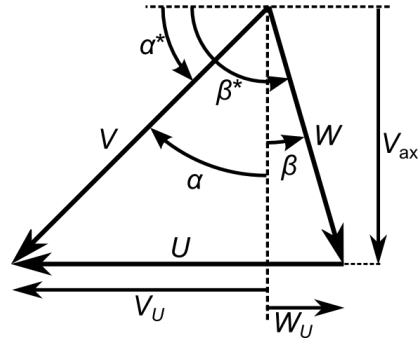

In GasTurb 13, each stage is represented by three triangles: at stage inlet, between rotor and stator, and at stage exit, see picture below. The triangle at the exit of a stage is not necessarily the same as the triangle at the inlet of the subsequent stage. It is assumed the radius of three stage triangles is constant and equal to the mean radius at stage inlet, which is the radius that divides the annulus into two equal areas. Therefore, a possible change of the mean radius within the stage is neglected. Consequently, the rotational speed U is constant for the three triangles of a stage. Furthermore, a constant axial velocity V_{ax} for all triangles of a stage is assumed. Finally, a "repeating" stage is assumed, which means that the inlet and exit triangles are identical. With these simplifications, the three triangles of a stage are uniquely defined by a set three dimensionless coefficients:

$$\rho_h = \frac{\Delta H'_s}{\Delta H'_s + \Delta H''_s}$$

$$\varphi = \frac{V_{ax}}{U}$$

$$\psi_h = \frac{\Delta H_s}{U^2}$$

where ρ_h is the *Enthalpy Reaction*, φ is the *Flow Coefficient* and ψ_h is the *Loading*. The static enthalpy differences $\Delta H'_s$ and $\Delta H''_s$ apply to rotor and stator respectively, with their sum being the stage static enthalpy difference ΔH_s . Using Euler's equation, it can be shown that the row inlet velocities can then be expressed as:

$$W_1 = U \cdot \sqrt{\left(\rho_h + \frac{\psi_h}{4}\right)^2 + \varphi^2}$$

$$V_2 = U \cdot \sqrt{\left(1 - \rho_h + \frac{\psi_h}{4}\right)^2 + \varphi^2}$$

Once the velocity triangles are known, the enthalpy changes within the stage are known. Therefore, these dimensionless coefficients are the main design variables of each individual stage. In contrast to all other stages, the flow coefficient of the first stage is not a freely selectable input parameter. It is already determined by the compressor inlet Mach number, rotational speed and the inlet radii, all of these being given from the cycle results and engine geometry.

The pressure rise within a compressor stage is accomplished through diffusions within the rotor and the stator of the stage. The picture below shows the compression process for the mean line flow within an enthalpy-entropy diagram for small pressure ratios. The process starts at station 1_s that



indicates the static state at the inlet of the stage and its rotor. The air enters the rotor with the relative velocity W_1 and is diffused to a relative velocity of W_2 at constant relative total enthalpy indicated by the states 1_r and 2_r . Next, the air enters the stator with the velocity V_2 and is again diffused to the velocity V_3 . This process happens at constant total enthalpy indicated by the states 2 and 3.

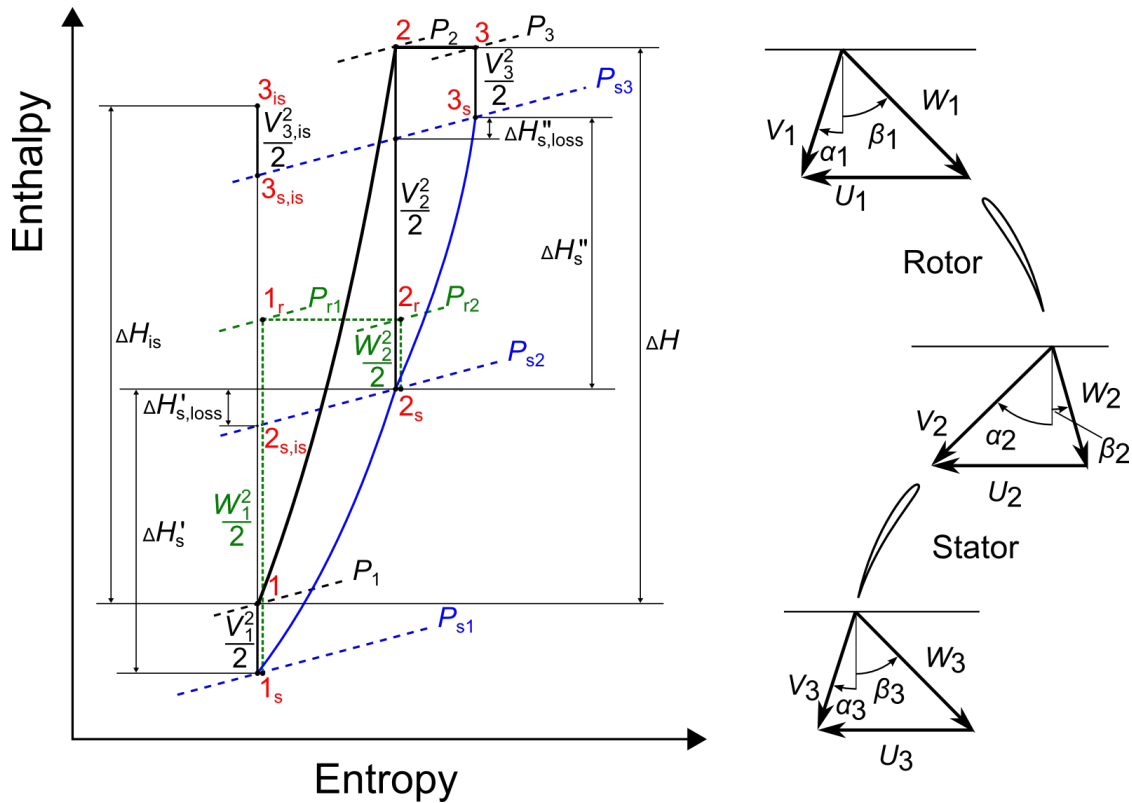

Besides the three above mentioned design variables, another design variable exist that has no influence on the velocity triangles. This is the *Pitch to Chord Ratio* (inverse solidity), which can be prescribed for each row. Note: The *Aspect Ratio*, which is usually also considered a design variable, is not among the input variables in GasTurb 13, since it is implicitly given by the boundary condition of *Row Inlet and Exit Axial Positions*.

The design variables are accompanied by a set of *Design Parameters*. These describe the stage and row design in more detail and provide information which will be necessary when evaluating loss correlations (e.g. *Tip Clearance*). Geometric row parameters can be given as either absolute or relative numbers (e.g. *Tip Clearance/Height*). The *Blockage Factor* reflects the reduction of the aerodynamically useful area compared to the geometric area. All design variables and parameters are listed in the first tab of the *Aerodynamic Design* window.

▼ **Loss and Efficiencies**

The analysis of the compression with regards to enthalpy is sufficient to calculate the exit temperature of a stage. However, it is insufficient for calculation of the exit pressure because the diffusion processes within the compressor stage are lossy due to several mechanisms described below. The loss mechanisms increase the entropy and lead to lower pressure at constant enthalpy. These losses can be expressed in several ways. In GasTurb 13 the losses are represented by the *Loss Coefficient* ζ . For each row, a loss coefficient is defined to represent the respective losses. During the design calculation, the loss coefficients of the rotor and the stator are then used to calculate the efficiency of a single stage. With this efficiency, the exit pressure is calculated which

is then used as the inlet pressure of the next stage. After a stage-by-stage calculation of the compressor, the compressor efficiency is computed. In the following the relation between the row loss coefficients and stage efficiency is described.

The isentropic efficiency of a single stage is defined as

$$\eta_{is} = \frac{\Delta H_{is}}{\Delta H}$$

Assuming a repeating stage and further defining $V_3 = V_{3,is}$ this expression can for small pressure and temperature rises be written as

$$\eta_{is} = 1 - \frac{\Delta H'_{s,loss} + \Delta H''_{s,loss}}{\Delta H}$$

using the loss enthalpies $\Delta H_{s,loss}$ of each row with one apostrophe referring to the rotor and two referring to the stator. The loss enthalpies are related to the relative inlet velocity of the respective blade row to get the definition of the loss coefficient ζ .

$$\zeta' = \frac{\Delta H'_{s,loss}}{W_1^2 / 2}$$

$$\zeta'' = \frac{\Delta H''_{s,loss}}{V_2^2 / 2}$$

In GasTurb 13 the row loss coefficients are either calculated by loss models or are prescribed directly by the user. The *Analytical* loss model is based on the methods of *Denton/Traupel* and is described in the following section. A second semi-empirical loss model called *Grieb/Gumucio/Schill* is available as well and is described in [reference 34,35](#). Alternatively, the value for each row loss coefficients can be entered directly by the user if *Prescribed* is selected.

▼ Analytical Loss Model (Denton/Traupel)

The analytical loss model is derived in [reference 32](#). This model avoids the use of empirical data in order to account for a wide range of applications. Note, however, that this model might require some calibration by the user in order to generate sound results. Once calibrated, the user can conduct sensitivity studies in his work. One particularly suitable example might be a well documented compressor such as [reference 36](#), which was used for validation of the code.

The model takes into account several loss mechanisms and calculates for each a respective loss coefficient. It then calculates the overall loss coefficient by summing the loss coefficients of each loss mechanism

$$\zeta = \zeta_{Profile} + \zeta_{TrailingEdge} + \zeta_{Shock} + \zeta_{RadialGap} + \zeta_{AxialGap}$$

The derivation of all loss coefficients is performed with a mean line analysis, using the mid section geometric parameters. The mid section is located at the radius that divides the annulus into two equal areas. The stagger angles of all blades and vanes are calculated as the averages of the respective inlet and exit flow angles. This gives a relationship between the *Axial Chord* (given from



Engine Geometry) and the True Chord (required for loss calculations). The aspect ratios of GasTurb 13 are defined as quotient of blade height at row inlet and axial chord.

$$r_m = \sqrt{\frac{r_o^2 + r_i^2}{2}}$$

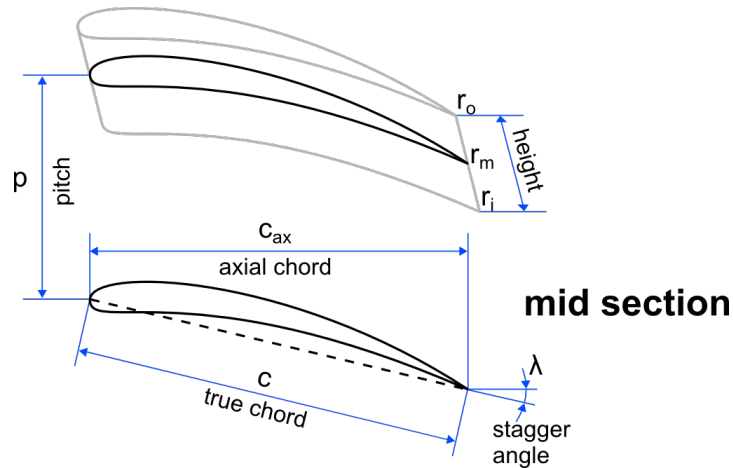

Profile Loss

The Profile Loss is calculated based on the dissipation in turbulent boundary layers, with the velocities at suction and pressure sides of the airfoil adapted to match the momentum required by the flow turning of each row. The diffusion coefficient c_D of the boundary layer is relatively insensitive to the shape of the boundary layer for a wide range of Reynolds numbers and can therefore reasonably be approximated with a value of $c_D = 0.002$. For strongly diffusing (or accelerating) flows, different factors apply (references [32,33]). The solidity of the blade is taken into account by the true chord c and the pitch p .

$$\zeta'_{Profile} = c_D \cdot \frac{W_1 + W_2}{V_{ax} W_1^2} \left(\frac{c}{p} (W_1^2 + W_2^2) + \frac{2c}{p} (W_{U2} - W_{U1})^2 \right)$$

$$\zeta''_{Profile} = c_D \cdot \frac{V_2 + V_3}{V_{ax} V_2^2} \left(\frac{c}{p} (V_2^2 + V_3^2) + \frac{2c}{p} (V_{U3} - V_{U2})^2 \right)$$

Trailing Edge Loss

The Trailing Edge Loss accounts for the pressure drop at the trailing edge, the mixing of wake and free stream as well as losses due sudden flow expansion. All three of these effects are represented in this order in the right numerator of the following equations, where δ_t is the thickness of the trailing edge and c_b is the base pressure coefficient. Typical values of c_b are in the range of 0.1-0.2. Mixing of the wake dominates this loss factor. It is assumed complete before the next row entry. The boundary layer displacement thickness δ_1 and momentum thickness δ_2 are estimated based on the Reynolds number and correlations for the turbulent boundary layer of a flat plate (reference [32]).

$$\zeta'_{TrailingEdge} = \frac{V_{ax} W_2}{W_1^2} \left(\frac{c_b \delta_t p + 2\delta_2 p + (\delta_1 + \delta_t)^2 \cdot W_2 / V_{ax}}{(p \cdot V_{ax} / W_2 - \delta_t - \delta_1)^2} \right)$$



$$\zeta''_{\text{TrailingEdge}} = \frac{V_{\text{ax}} V_3}{V_2^2} \left(\frac{c_b \delta_t p + 2\delta_2 p + (\delta_1 + \delta_t)^2 \cdot V_3 / V_{\text{ax}}}{(p \cdot V_{\text{ax}} / V_3 - \delta_t - \delta_1)^2} \right)$$

Shock Loss

The *Shock Loss* comprises either transonic or supersonic losses, depending on the inlet conditions (reference [34]). Since neither profile contour nor shock system are known, the supersonic loss (for $M_1 > 1$) is assumed to originate from a single normal shock in the blade passage alone. Only flow Mach numbers relative to the respective blade are used here. The pre shock Mach number M_{SS} is calculated from the inlet Mach number M_1 and a maximum suction side Mach number $M_{\text{max,SS}}$. The maximum suction side Mach number is calculated from the supersonic expansion on the suction side, using the Prandtl-Meyer function ϑ . The amount of expansion is described by the *Supersonic Deflection Angle* ϑ_{SS} . The supersonic deflection angle is unknown and has to be prescribed relative to the *Overall Flow Deflection of the Blade Row* ϑ_{∞} , which is the difference between the inlet and exit angle, by means of the *Supersonic Deflection Ratio* $\vartheta_{\text{SS}} / \vartheta_{\infty}$. This parameter ranges from 0 (subsonic compressor row, no shock losses) to 1 (supersonic compressor row).

$$\vartheta_{\text{SS}} = \vartheta(M_{\text{max,SS}}) - \vartheta(M_1) \quad [\text{to be solved for } M_{\text{max,SS}}]$$

$$M_{\text{SS}} = \frac{M_1 + M_{\text{max,SS}}}{2}$$

$$\zeta_{\text{Shock}} = \frac{2P_1}{\rho_{\text{sl}} W_1^2} \left(1 - \frac{\left(\frac{\frac{\gamma+1}{2} M_{\text{SS}}^2}{1 + \frac{\gamma-1}{2} M_{\text{SS}}^2} \right)^{\frac{\gamma}{\gamma-1}}}{\left(\frac{2\gamma}{\gamma+1} M_{\text{SS}} - \frac{\gamma-1}{\gamma+1} \right)^{\frac{1}{\gamma-1}}} \right) \quad \text{for } M_1 > 1$$

The transonic loss (for $M_1 < 1$) is assumed to occur only if the inlet Mach number exceeds the critical Mach number ($M_1 > M_{\text{Critical}}$). It is then estimated based on a continuous transition to supersonic losses at $M_1 = 1$. Since both strength and size of the shock wave increase between these two boundary points of the interpolation, the interpolating function is assumed a parabola:

$$\zeta_{\text{Shock}} = \zeta_{\text{Shock}, M_1=1} \left(\frac{M_1 - M_{\text{Critical}}}{1 - M_{\text{Critical}}} \right)^2 \quad \text{for } 1 > M_1 > M_{\text{Critical}}$$

This transonic loss correlation matches the supersonic loss at an inlet Mach number of 1. The loss decreases with decreasing inlet Mach number and becomes 0 at the critical inlet Mach number. Below critical row inlet conditions, no shock loss occurs:

$$\zeta_{\text{Shock}} = 0 \quad \text{for } M_{\text{Critical}} > M_1$$

Tip Clearance Loss



The *Tip Clearance Loss* (also named *Tip Leakage Loss* or *Radial Gap Loss*) can be calculated for shrouded and cantilevered blade rows (reference [32]). For cantilevered configurations, the same velocities at pressure and suction sides are used as in the determination of the profile loss. Since the integration cannot be performed analytically, the resulting equation system is more complex than the profile loss correlations and needs to be integrated numerically at runtime. The pressure gradient at the blade tip causes a mass flow from the pressure to the suction side, which mixes with the free stream on the suction side. This causes losses which are then integrated along the (nondimensionalized) chord to get the overall loss.

$$\zeta'_{\text{Radial}} = \frac{2c_c \delta_g c}{W_1^2 V_{\text{ax}} h p} \int_0^1 W_{\text{SS}} (W_{\text{SS}} - W_{\text{PS}}) \sqrt{W_{\text{SS}}^2 - W_{\text{PS}}^2} dx$$

with the gap height (also named tip clearance) δ_g , the contraction coefficient c_c , and the blade height h . A typical value for c_c would be 0.6. The pressure and suction side velocities along the chord are approximated with the mean line velocities

$$W_{\text{SS}}(x) = (W_2 - W_1 - \Delta W_U)x + W_1 + \Delta W_U$$

$$W_{\text{PS}}(x) = (W_2 - W_1 + \Delta W_U)x + W_1 - \Delta W_U$$

where $x = 0$ corresponds to the leading edge and $x = 1$ to the trailing edge. The velocity difference ΔW_U is adjusted to match the flow turning of the blade row:

$$\Delta W_U = (W_{U2} - W_{U1}) \frac{p}{c}$$

With a similar approach, the tip clearance losses can be calculated for stator rows. In contrast to rotors, stators can alternatively be shrouded. In shrouded rows, the pressure gradient driving the leakage flow is then not the difference between pressure and suction side, but the difference between row exit and row inlet. The leakage mass flow through the seal fins and its pressure losses are added up with the mixing losses of leakage and free stream mass flows at row inlet to get the overall radial loss (reference [32])

$$\zeta''_{\text{Radial}} = \frac{4c_c \delta_g r_i}{(r_o^2 - r_i^2) \sqrt{n}} \sqrt{1 + \frac{V_{U2}^2 - V_{U3}^2}{V_{\text{ax}}^2}} \left(1 - \frac{V_{U2} V_{U3}}{V_2^2} \right)$$

where n denotes the number of seal fins employed, δ_g stands for the running clearance of the seals and c_c is the contraction coefficient.

Axial Gap Loss

The *Axial Gap Loss* (also named *Annulus Loss*) accounts for the side wall friction upstream and downstream of the blade rows. It is approximated based on a pipe flow, where the hydraulic diameter is twice the blade height h and the equivalent pipe length is the axial gap between the blade rows $\delta_{g,\text{ax}}$ multiplied by a velocity ratio to account for swirl. A typical value for the friction factor would be $\lambda = 0.08$.

$$\zeta'_{\text{AxialGap}} = \frac{\lambda \delta_{g,\text{ax}}}{2h} \cdot \frac{W_2^3}{V_{\text{ax}} W_1^2}$$

$$\zeta''_{\text{AxialGap}} = \frac{\lambda \delta_{g,ax}}{2h} \cdot \frac{V_3^3}{V_{ax} V_2^2}$$

▼ Design Algorithm

The design calculation is based on the above listed boundary conditions, which can also be seen in the second tab of the *Aerodynamic Design* window, as well as the *Design Variables* and *Design Parameters*. It is always the same procedure, regardless of the selected loss parameter model.

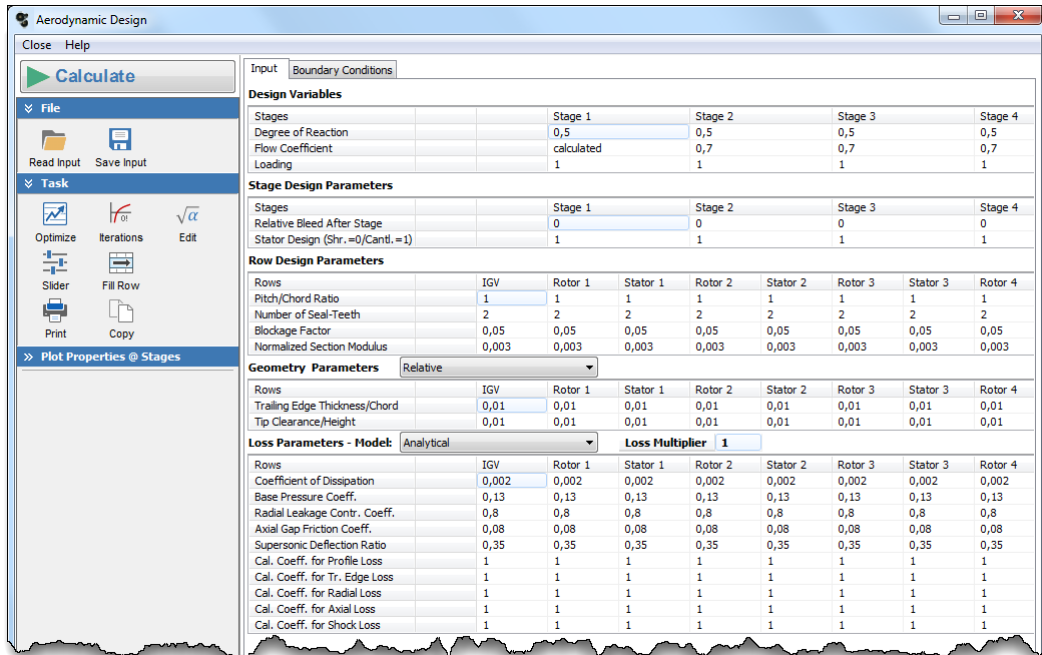

Design Variables

Stages	Stage 1	Stage 2	Stage 3	Stage 4
Degree of Reaction	0,5	0,5	0,5	0,5
Flow Coefficient	calculated	0,7	0,7	0,7
Loading	1	1	1	1

Stage Design Parameters

Stages	Stage 1	Stage 2	Stage 3	Stage 4
Relative Bleed After Stage	0	0	0	0
Stator Design (Shr.=0/Cantl.=1)	1	1	1	1

Row Design Parameters

Rows	IGV	Rotor 1	Stator 1	Rotor 2	Stator 2	Rotor 3	Stator 3	Rotor 4
Pitch/Chord Ratio	1	1	1	1	1	1	1	1
Number of Seal-Teeth	2	2	2	2	2	2	2	2
Blockage Factor	0,05	0,05	0,05	0,05	0,05	0,05	0,05	0,05
Normalized Section Modulus	0,003	0,003	0,003	0,003	0,003	0,003	0,003	0,003

Geometry Parameters (Relative)

Rows	IGV	Rotor 1	Stator 1	Rotor 2	Stator 2	Rotor 3	Stator 3	Rotor 4
Trailing Edge Thickness/Chord	0,01	0,01	0,01	0,01	0,01	0,01	0,01	0,01
Tip Clearance/Height	0,01	0,01	0,01	0,01	0,01	0,01	0,01	0,01

Loss Parameters - Model: Analytical **Loss Multiplier:** 1

Rows	IGV	Rotor 1	Stator 1	Rotor 2	Stator 2	Rotor 3	Stator 3	Rotor 4
Coefficient of Dissipation	0,002	0,002	0,002	0,002	0,002	0,002	0,002	0,002
Base Pressure Coeff.	0,13	0,13	0,13	0,13	0,13	0,13	0,13	0,13
Radial Leakage Contr. Coeff.	0,8	0,8	0,8	0,8	0,8	0,8	0,8	0,8
Axial Gap Friction Coeff.	0,08	0,08	0,08	0,08	0,08	0,08	0,08	0,08
Supersonic Deflection Ratio	0,35	0,35	0,35	0,35	0,35	0,35	0,35	0,35
Cal. Coeff. for Profile Loss	1	1	1	1	1	1	1	1
Cal. Coeff. for Tr. Edge Loss	1	1	1	1	1	1	1	1
Cal. Coeff. for Radial Loss	1	1	1	1	1	1	1	1
Cal. Coeff. for Axial Loss	1	1	1	1	1	1	1	1
Cal. Coeff. for Shock Loss	1	1	1	1	1	1	1	1

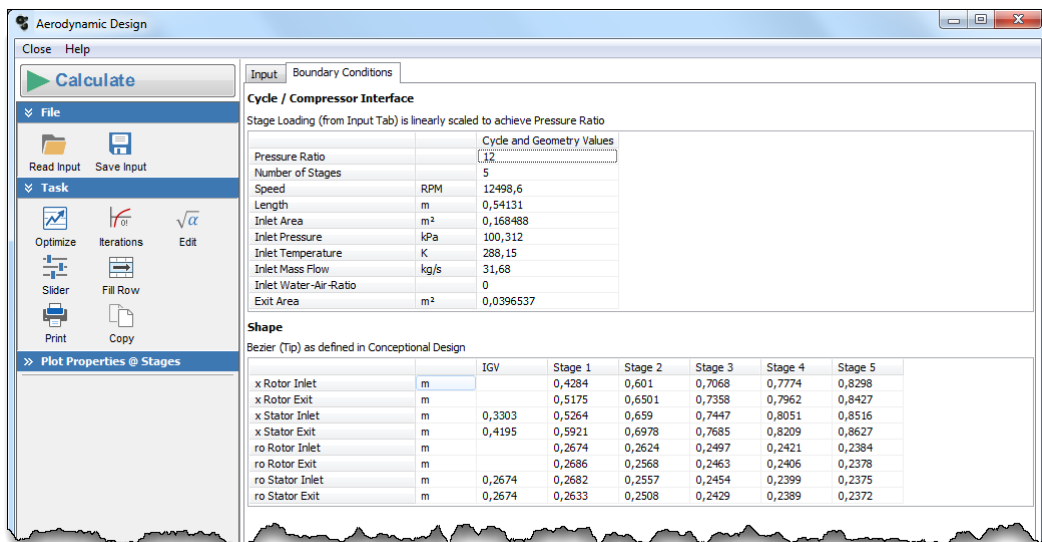

Cycle / Compressor Interface

Stage Loading (from Input Tab) is linearly scaled to achieve Pressure Ratio

Cycle and Geometry Values	
Pressure Ratio	12
Number of Stages	5
Speed	RPM 12498,6
Length	m 0,54131
Inlet Area	m² 0,168488
Inlet Pressure	kPa 100,312
Inlet Temperature	K 288,15
Inlet Mass Flow	kg/s 31,68
Inlet Water-Air-Ratio	0
Exit Area	m² 0,0396537

Shape

Bezier (Tip) as defined in Conceptual Design

	IGV	Stage 1	Stage 2	Stage 3	Stage 4	Stage 5
x Rotor Inlet	m 0,4284	0,601	0,7068	0,7774	0,8298	
x Rotor Exit	m 0,5175	0,6501	0,7358	0,7962	0,8427	
x Stator Inlet	m 0,3303	0,5264	0,659	0,7447	0,8051	0,8516
x Stator Exit	m 0,4195	0,5921	0,6978	0,7685	0,8209	0,8627
ro Rotor Inlet	m 0,2674	0,2624	0,2497	0,2421	0,2384	
ro Rotor Exit	m 0,2686	0,2568	0,2463	0,2406	0,2378	
ro Stator Inlet	m 0,2674	0,2682	0,2557	0,2454	0,2399	0,2375
ro Stator Exit	m 0,2674	0,2633	0,2508	0,2429	0,2389	0,2372

The compressor design is calculated beginning with the first stage rotor, then advancing through the stages. The procedure is almost identical for all rows:

- The row inlet conditions (total pressure, total temperature, gas properties) are known



- Calculation of flow velocities as function of ρ_h , φ , Ψ_h
- Calculation of static pressure, static temperature
- Calculation row inlet cross sectional area and radii (skipped for the first rotor)
- Evaluation of the row loss correlations
- Calculation of the row exit conditions and additional parameters (e.g. Lieblein Factor)
- Shift to the next row

If a design includes *Inlet Guide Vanes*, they are calculated before the first stage. The IGVs are assumed to turn the axial flow and generate a swirl prior to the first stage rotor. The swirl angle is chosen as prescribed by the first rotors velocity triangle.

Once the design calculation is finished for all rows, the pressure ratio and the efficiency can be calculated from its inlet and exit conditions. As the input values for the loading Ψ_h have been selected unaware of the losses, the pressure ratio delivered by the designed compressor will normally not match the cycle pressure ratio. Therefore, all loading input values are multiplied with a scaling factor and the design calculation is repeated until matching pressure ratios are obtained. The results are then displayed in the output tab of the *Aerodynamic Design* window. The result's loading of each stage can be found under *Calculated Loading*.

There are also values named *Calculated Flow Coefficient* and *Calculated Reaction*. These are identical with the input variables, except for the first stage flow coefficient which is not an input variable. They may only deviate if the *Sketch* option for annulus definition was chosen to prescribe a known compressor which is then analyzed by means of additional iterations to determine its design variables.

Among the results are aspect ratios for all rows, which are defined as quotient of blade height at row inlet and axial chord. The axial chord is a known boundary condition from the *Engine Geometry*, given in the form of *Row Inlet and Exit Axial Positions*. Since the blade height of each row is a function of the annulus area and thus a function of pressure ratios and efficiencies of upstream blade rows, the aspect ratios are a result of the aerodynamic design calculation. The axial gap is also known from the *Row Inlet and Exit Axial Positions*, prescribed by the *Engine Geometry*.

▼ Graphical Output

The *Aerodynamic Design* window offers four ways of graphically visualizing the design results. Velocity triangles and Mach number triangles are displayed in the *Triangles* tab. The definition of the angles can be chosen here as well. If the *Axial* definition is selected, then the angles are measured relative to the compressor axis with positive angles in the direction of rotation. This definition is consistent with the definition in Turbine Design. Alternatively, the *Circumferential* definition can be selected where the angles are measured relative to the direction of rotation. A drawing of the aerodynamically designed annulus can be accessed with the *Drawing* tab. For comparison, the conceptual design geometry can be drawn in the background. Also, up to four output *Properties at Stages* can be plotted by selecting them in the check box list on the left and clicking *Plot*. Stage and row specific values can be drawn in the same plot. If a *Row* property is selected, then the values of the stator are plotted at the Stage number +0.5 (the pressure of the second stator would e.g. be plotted at the x-coordinate 2.5).

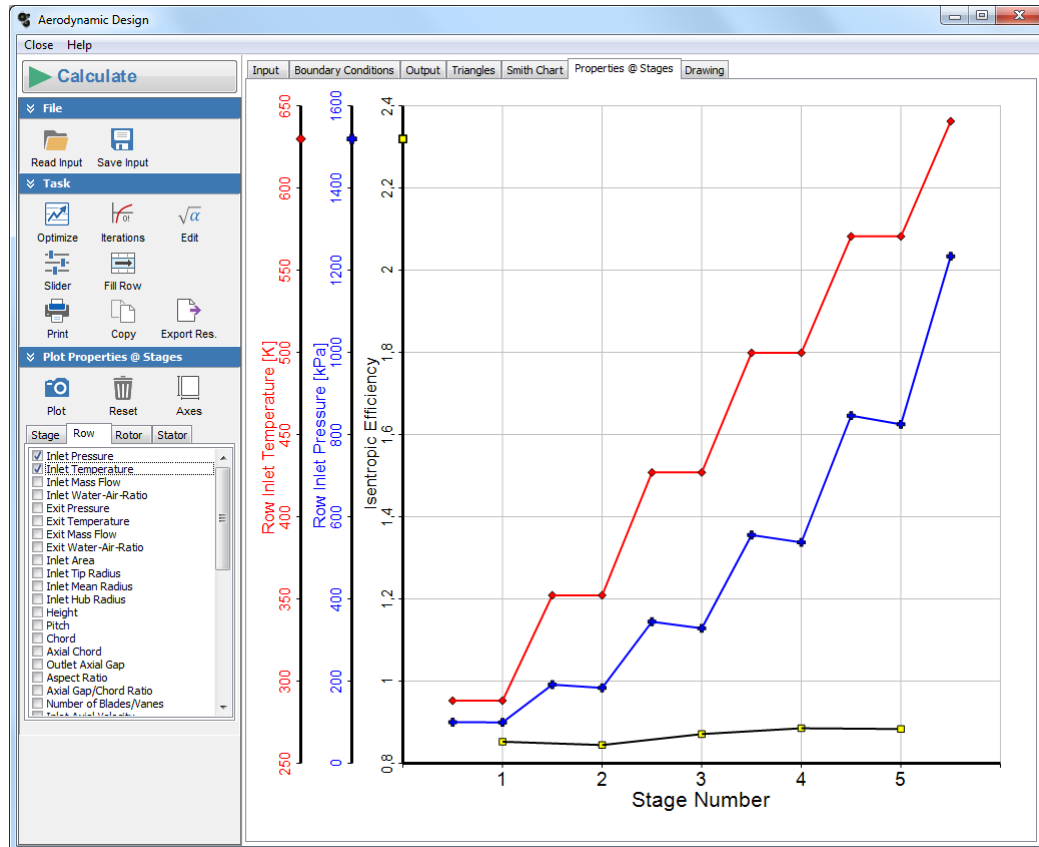

Finally, the design can be plotted in *Smith Charts* of each stage. These are plots of Ψ_h over ϕ , depicting stage efficiency trends as colored contours. The *Smith Charts* in GasTurb 13 are calculated with the selected loss correlation, the design parameters, and the stage geometry for rotor and stator. They allow the user to optimize the design. The current parameter combination of the respective stage is shown as a black square. Stability margins can be included in the plot by checking the boxes *De Haller Limit* and *Lieblein Limit*. The more critical stability margin (either rotor or stator) defines the plotted boundary. Selecting the stage 0 will yield a plot with no contours but all stages combinations of Ψ_h and ϕ .

▼ Optimization

The *Aerodynamic Design* offers an optimization to automatically find a combination of input parameters which yields e.g. best efficiency. The *Optimization Input* window can be accessed by clicking *Optimization* in the *Aerodynamic Design* window. Here, the variables and constraints of the optimization are selected from the input and output values of the aerodynamic design. Also, the figure of merit can be defined. While all stage output parameters can serve as figure of merit, a most useful choice would be compressor efficiency.

To configure an optimization variable, it must be selected in the list of *Available Variables* first. Then there are four options to optimize a variable. *Individual Points* indicates, that the variable will be optimized independently for each stage within the prescribed *Min* and *Max* bounds. Start values of the optimization are always taken from the *Aero Design Input* window and hence cannot be modified. The optimization limits can be set in the rows labeled *Min* and *Max*. By checking the *Freeze* box beneath a certain stage number, the respective variable is excluded from the optimization.



In order to facilitate quick studies, variables can be optimized with a reduced degree of freedom. This is what the options *Constant*, *Line* and *Parabola* can be used for. The variable will still be optimized for all stages by employing up to three sampling points which define a line or curve shape.

If *Constant* is selected, the variables for all stages are set to the value of the first stage. *Line* indicates, that the values of both first and last stage are optimized and the values in between them are interpolated. In case of the *Parabola*, additionally the middle point can be freely chosen and all variables aside from first, last and middle stage are quadratically interpolated.

Flow Coefficient and *Loading* of the first stage cannot be configured as optimization variables. This is because the *Flow Coefficient* of the first stage is not a variable in the aerodynamic design, since it is a result of speed, flow and Mach number as prescribed by the cycle calculation. Since the *Loading* is a relative parameter, it is not reasonable to optimize it for all stages independently. The value of the first stage must stay unmodified as a reference. Hence, the optimization option *Constant* is not available for *Flow Coefficient* and *Loading*.

If the optimization of a variable is configured, its name will be shaded in blue in the *Available Variables* list. To deactivate the optimization, select *None*.

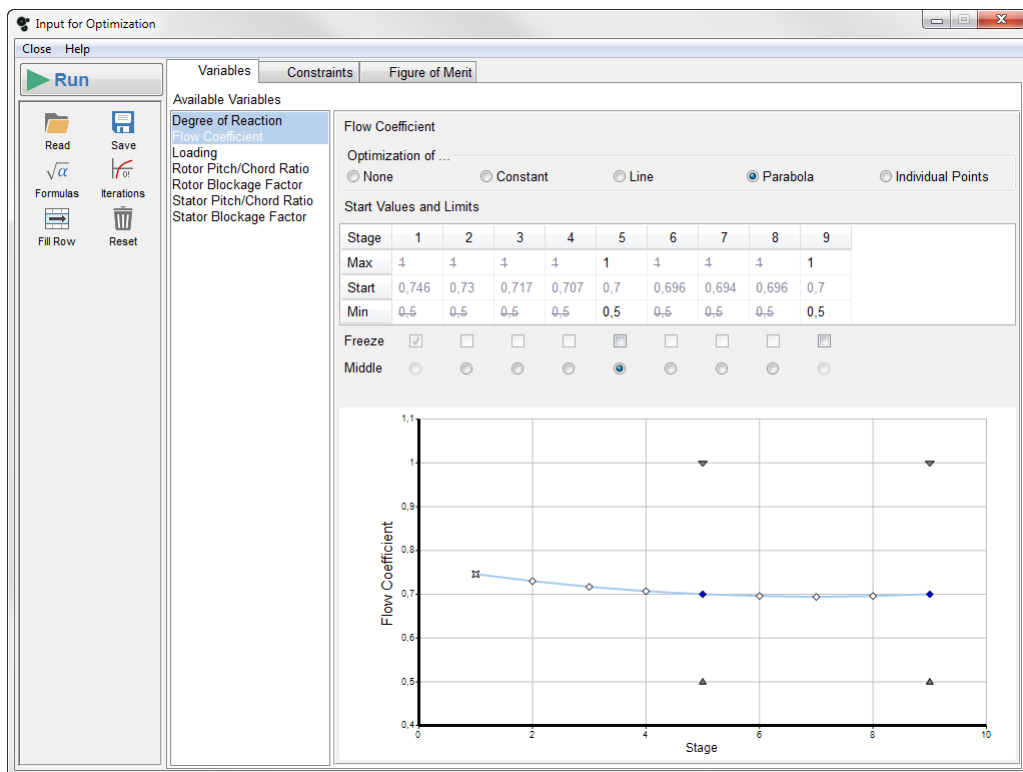

The optimization constraints can be configured similar to the variables. After selecting from the available constraints, the respective numbers can be set for each stage. The limits can either be defined individually, as a line, or as curve shape with a limited number of sampling points in order to facilitate quick studies. If the observance of a constraint is configured, its name will be shaded in red in the *Available Constraints* list. To deactivate the optimization constraint, select *None*.

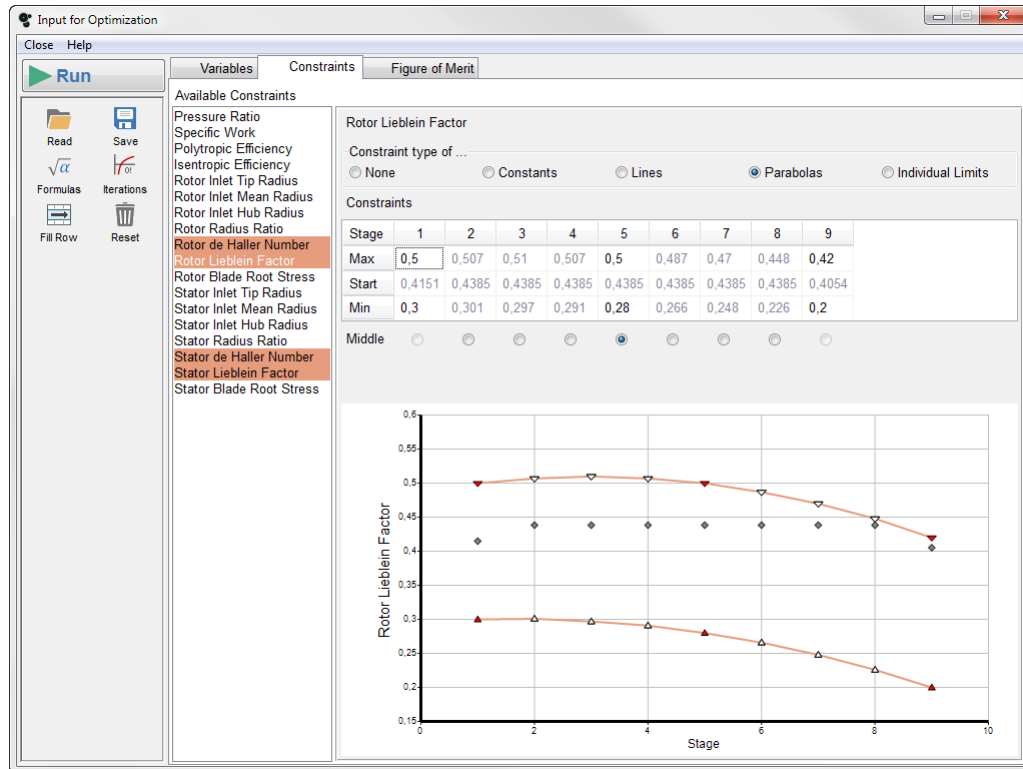

The configuration of all optimization variables, constraints and the figure of merit can be saved and restored by means of the respective buttons.

All settings can be cleared by clicking the *Reset* button.

The *Run* button starts the optimization and opens the *Optimization Progress* window, showing the optimization status and obtained values for the figure of merit.

Recommended Optimization Strategies

In order to achieve reliable results, the following characteristics of the optimization should be considered:

- It is based on a gradient method. While stable and fast, this method is prone to finding local optima, sometimes far away from the global optimum. It is therefore advisable to start with a set of input parameters which is as reasonable (and close to the solution) as possible. Although the optimization with a large number of variables is usually conducted pretty fast, too many and too loosely defined optimization variables will almost certainly lead to the discovery of only a local optimum.
- It relies greatly on the loss model of the compressor. Therefore, the model should be fed with accurate and reasonable parameters before starting the optimization. This includes for example *Blockage* and *Pitch/Chord Ratios*. If the solver favors the first or last stages heavily, this bias may be due to a unrealistically defined loss mechanism.
- It usually needs constraints regarding aerodynamic stability (*Lieblein Factor*, *de Haller Number*), since otherwise the low-loss stages will be overloaded.
- Input values defined by *Constant*, *Line* or *Parabola*, by design, differ from the aerodynamic design input. If the resulting design violates constraints, running the optimization will yield an error message since its starting point is invalid. In this case, the *Individual Points* option must be used instead of *Constant*, *Line* or *Parabola*.



Strategies to simplify evaluation of the results include the following:

- Optimizing aerodynamic parameters first (*Reaction, Flow Coefficient, Loading*) and the geometry later. This restricts interdependencies and facilitates the physical interpretation of the result.
- Defining the optimization variables as *Constant, Line* or *Parabola* at the beginning of the optimization process and optimizing the individual stage's values later. This offers clearer curve shapes to interpret. The shapes defined by *Constant, Line* or *Parabola* should not differ too much from the aerodynamic design input, however, as this will cause an extensive redesign and thus constraints may be violated.

The following characteristics of the aerodynamic design influence the optimization results and limit the solution space:

- The compressor interface is predefined by the cycle, including the speed. Some combinations of pressure ratios, mass flow and compressor speed may be impossible to realize, at least with an efficient and stably operating compressor
- The compressor exit flow is axial with no circumferential velocity component. The last stage's vane is thus highly loaded and may require a much lower *Pitch/Chord Ratio* than the rest of the stages. Therefore, defining the Stator *Pitch/Chord Ratio* as *Constant, Line* or *Parabola* may skew the results.

6.4.2 Radial Compressor

Generally, compressors in GasTurb 13 are of axial flow design. The gas generator compressor, however, can be a single or two stage radial compressor or an axial compressor followed by a radial end stage.

If the radial stage is preceded by one or more axial stages, then the *Rel. Work of Radial End Stage* is an input quantity. The efficiency of the radial end stage results from the conditions at the exit of the last axial stage and the overall compressor exit conditions which are known from the thermodynamic cycle.

6.4.2.1 Conceptual Design - Radial Stage

During engine design the mass flow W_1 , total enthalpy increase dh , total pressure ratio P_2/P_1 , angular velocity ω and all static properties in the inlet to the radial stage are known.

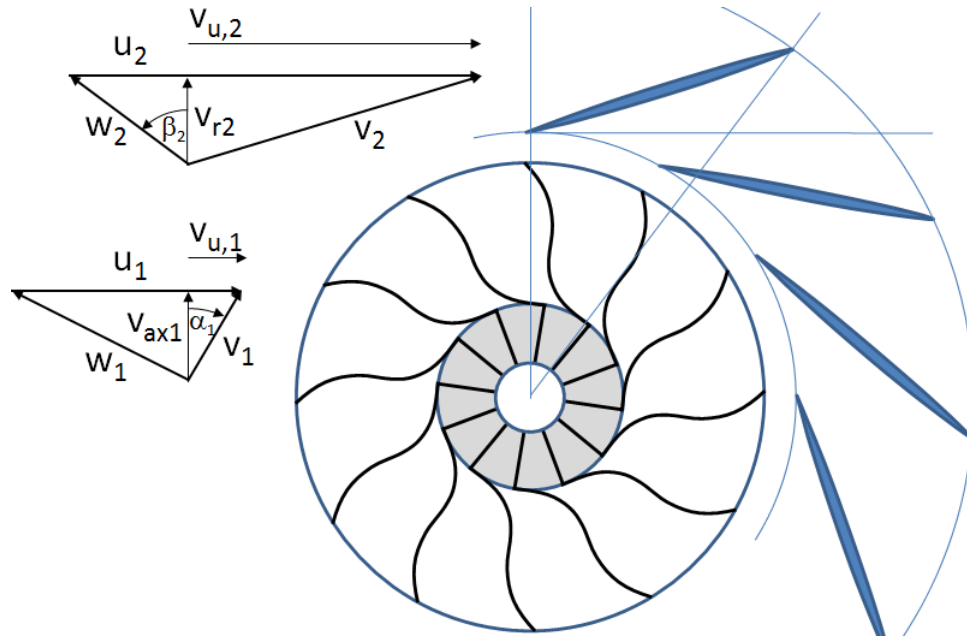

Euler's equation yields the correlation between specific work and the velocity triangles:

$$dh = u_2 \cdot v_{u,2} - u_1 \cdot v_{u,1}$$

All velocity triangle elements at the compressor inlet are known. The circumferential component of the rotor exit velocity $v_{u,2}$ can be expressed as

$$v_{u,2} = u_2 - v_{r,2} \cdot \tan \beta_2$$

In this equation β_2 is the back-sweep angle of the rotor blades. High values of β_2 reduce the inlet Mach number into the diffuser, however, rotors with backward leaning blades are associated with centrifugal bending stress problems. Therefore high speed radial compressors are frequently designed with straight radial blades.

The required impeller exit radius r_2 is

$$r_2 = \frac{1}{\omega} \sqrt{\frac{dh + u_1 \cdot v_{u,1}}{1 - v_{ax,1}/u_2 \cdot \tan \beta_2}}$$

Thus the rotor exit radius can be calculated if back-sweep angle β_2 and flow coefficient $\Phi = v_{r,2}/u_2$ are known.

The first part of a radial compressor is the inducer which has the task to turn the incoming flow into axial direction. Following the arguments from Ref. 27 we assume that downstream of the inducer, in the relative system, the velocity is equal to the axial component of the velocity $v_{ax,1}$ at the inducer entrance. In the second - i.e. the radial part of the rotor - the average flow velocity is kept roughly constant to lessen the possibility of boundary layer separation. Thus the radial component of the impeller exit velocity $v_{r,2}$ is equal to the axial component of inlet velocity $v_{ax,1}$ and the formula above can be rewritten as

$$u_2 = r_2 \cdot \omega = \sqrt{\frac{dh + u_1 \cdot v_{u,1}}{1 - v_{ax,1}/u_2 \cdot \tan \beta_2}}$$

This quadratic equation for u_2 has the solution



$$u_2 = \frac{1}{2} \left(v_{ax,1} \cdot \tan \beta_2 + \sqrt{(v_{ax,1} \cdot \tan \beta_2)^2 + 4 \cdot (dh + u_1 \cdot v_{u,1})} \right)$$

For calculating the impeller exit width the flow velocity v_2 is needed which can be found from the rotor exit velocity triangle:

$$v_2 = \sqrt{(u_2 - v_{ax,1} \tan \beta_2)^2 + v_{ax,1}^2}$$

Calculating the density at the impeller exit requires knowledge of the total pressure at this location. From the given specific work one can calculate P_{2is} , the total pressure at the rotor exit for an isentropic compression. The true total pressure at the rotor exit is estimated as mean value between P_{2is} and the stage exit total pressure.

Impeller exit width, which is the rotor blade height h_2 at the rotor exit, is found from

$$h_2 = \frac{W}{\rho \cdot v_{r,2} \cdot 2 \cdot \pi \cdot r_2}$$

The number of rotor blades is calculated from the assumption, that the distance between the blades is two times the blade height.

Between the rotor tip and the stator inlet there is a gap of the size $0.3 \cdot h_2$. The number of vanes in the diffuser is calculated from the same assumption as for the number of rotor blades: the distance between the vanes is two times h_2 .

6.4.2.2 Single Stage Geometry

The figure shows the geometry of a radial stage. The dimensions of the rotor inlet are known from the preceding stage or from the inlet. The size of the flow channel at the rotor exit is the result of the aerodynamic design. This, however, does not yield the axial dimension of the rotor. The axial length is calculated based on the exit radii and the aspect ratio.

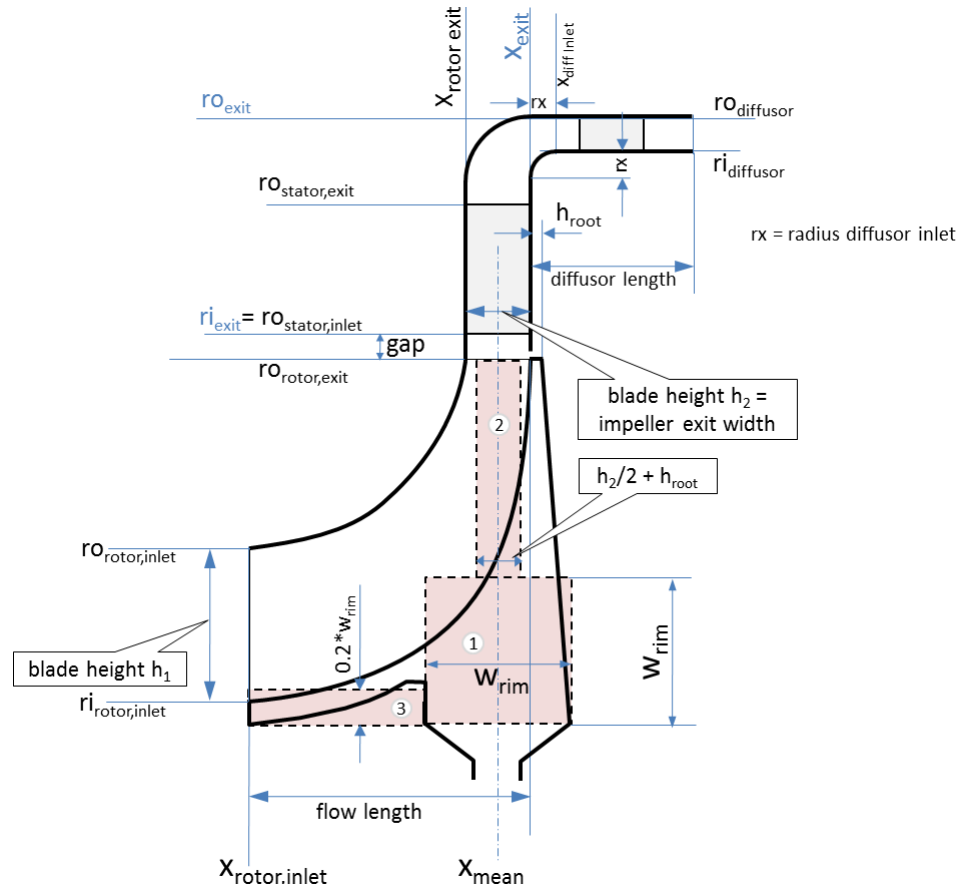

The disk rim width w_{rim} is 1.5 times the impeller exit width h_2 . The input quantity *Root Height/Blade Height* is employed for calculating h_{root} - the thickness of the rotor back plate at its exit - from h_2 . Three numbered gray areas indicate elements of the rotor mass calculation. Area 1 represents the rim of the live disk. The dead weight pulling at the disk rim is described with area 2. The third element has no influence on the calculated disk stress, it contributes only to the mass and to the inertia of the rotor.

Rotor blade mass is 10% of the three mass elements. The vanes are manufactured from the same material as the casing. Their mass is determined from the number and the size of the vanes in the diffuser and the input of *Mean Blid Thickness, [%] of Chord* which defines the thickness of the vanes.

The rotor blade length of a radial rotor is defined as the distance from the $r_{i,rotor,inlet}$ to $r_{o,rotor,exit}$. The blade annulus height is determined at the rotor exit and is equal to the impeller exit width.



6.4.2.3 Two Stage Geometry

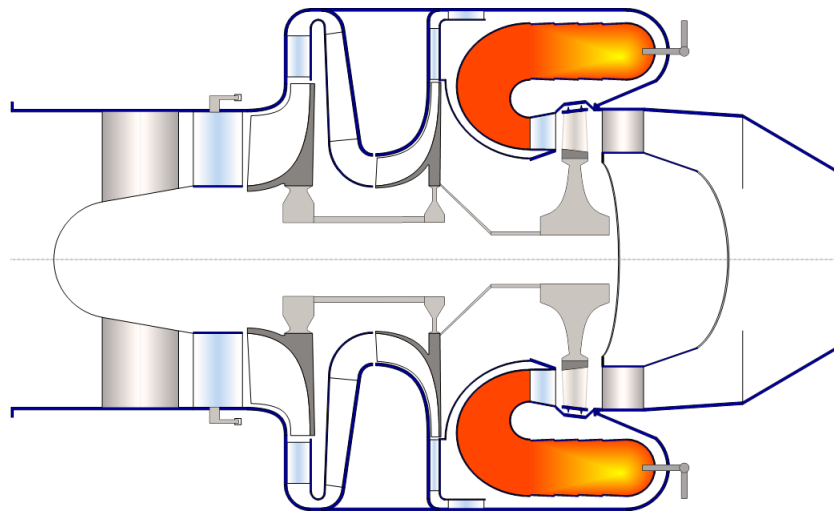

A two stage radial compressor is designed in such a way that the outer diameter of both stages as well as the inner radius of the rotor inlets are the same. The distance between both stages is controlled with the input quantity *Blade Gapping: Gap/Chord*.

The return duct after the first stage has on one side the outer casing thickness and on the other side the diffuser wall thickness.

6.5 Burner

6.5.1 Axial Flow Burner

The geometry of the annular burner is described with ratios of the dimensions that are explained in the figure.

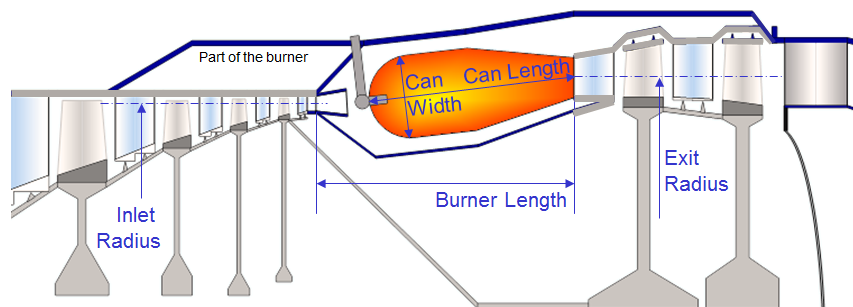

Note that the compressor exit diffuser extends into the burner. From a geometric perspective, however, the compressor ends with its exit guide vane.

The burner casing extends to the exit of the last high pressure turbine stage because the turbine outer casing is usually cooled with air bypassing the combustor can. Note that the calculated burner volume is not the volume within the burner casing, it is that of the can only.

The mass (weight) of the burner is composed of the can mass, inner and outer casing masses and fuel injector mass. The latter is considered to be proportional to fuel mass flow and takes - besides the injectors themselves - also the fuel pipes into account. Note that the mass of the diffuser is part of the compressor mass.

Casing and can masses are the product of their respective surface areas, a representative thickness and the material density.

6.5.1.1 Axial Flow Burner Design Example

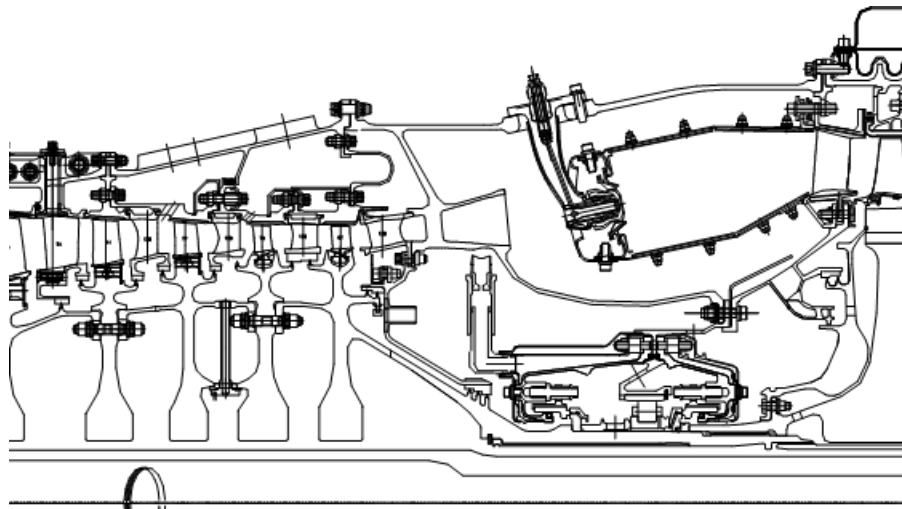

6.5.2 Reverse Flow Burner

The same property names are used as for axial flow burner geometry. However, the numbers for a nice design of a reverse flow burner are quite different to those for a well designed axial flow combustion chamber.

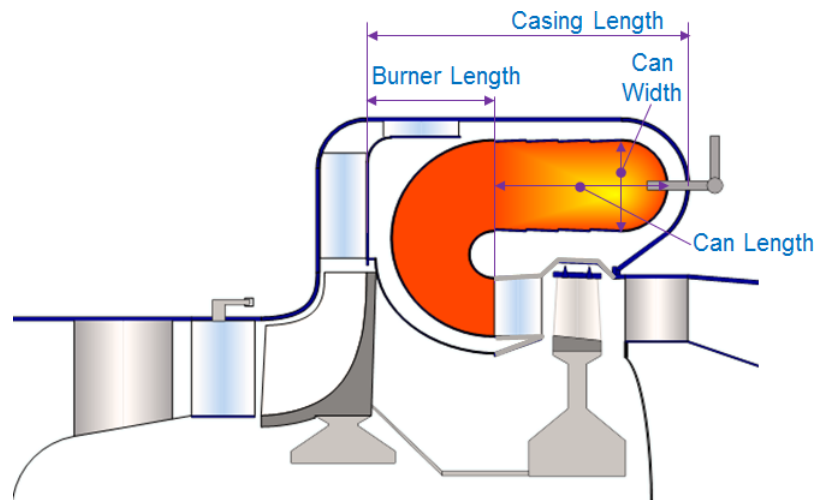

6.5.2.1 Reverse Flow Burner Design Example

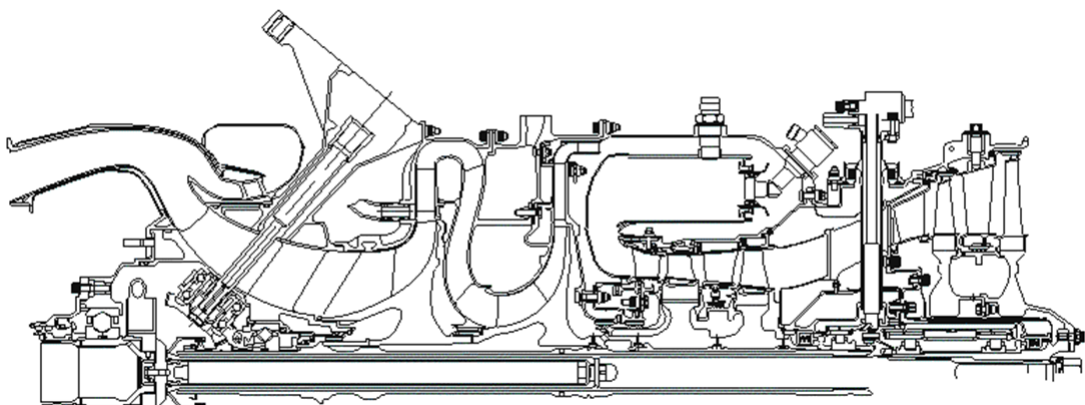



6.6 Turbine

The shape of a turbine flow annulus is described by the inner contour and the stage flow areas. These are calculated assuming equal aerodynamic loading $\Delta H/u^2$ for all stages. The axial Mach number at any intermediate position is interpolated linearly from the Mach number at the turbine inlet and exit stations. With these assumptions the stage inlet and exit flow areas as well as the blade and vane spans are found.

Note that the turbine cross section calculation is not in all details consistent with the data produced by the [Turbine Design](#) option.

Turbine blades may be shrouded or unshrouded. Without shroud the blade will be lighter and more easy to cool, however, the blade tip clearance can be contained within limits only if its tip radius is constant along the blade chord. This is because the turbine rotor moves in axial direction during operation due to thermal expansion and axial forces.

The blade and vane nomenclature is equivalent to that employed for [axial compressors](#).

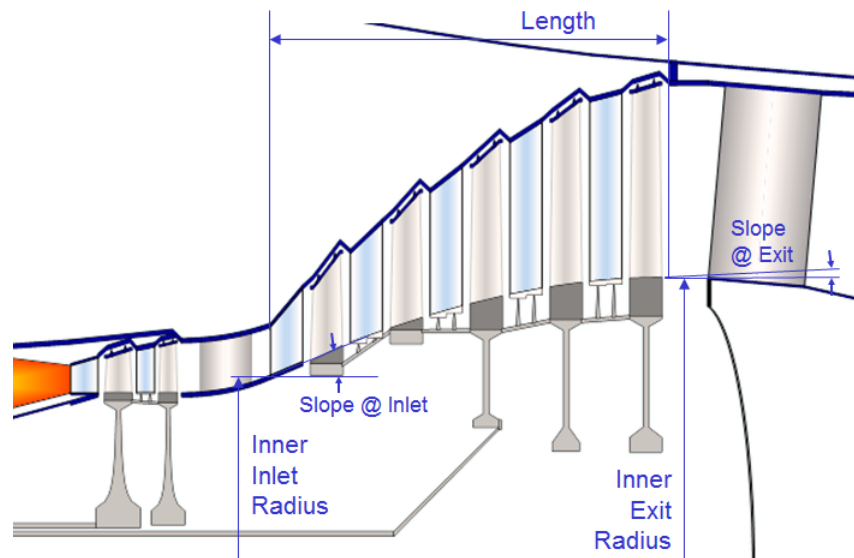

The mass (weight) of the turbine is composed of the following three elements:

- The casing mass which is the product of casing surface area, mean casing thickness and the density of the casing material.
- As part of the [disk stress calculation](#) the rotating mass is determined
- The vane mass, which consists of the airfoils and inner vane platforms

For getting a reasonable turbine mass result, select a representative casing material thickness which takes into account flanges, cooling air passages, pipes of an active clearance control system and any non axis-symmetric features which might exist. Note that cover-plates are not modeled; their mass must be taken into account additionally.

6.6.1 HP Turbine Design Example

As you can see, many details of a real turbine are not modeled explicitly in GasTurb 13. Therefore the mass (weight) numbers are always on the low side.

Note in this example the double wall outer casing which is required for the cooling air supply.

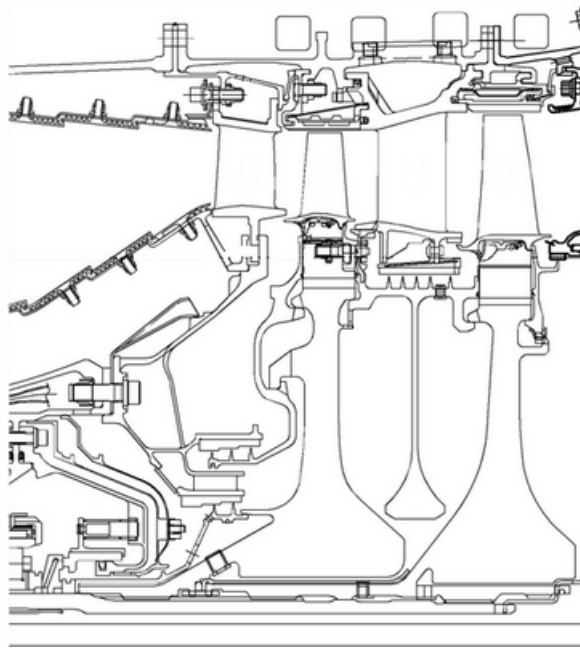

6.6.2 LP Turbine Design Examples

Low pressure turbine of a high bypass engine:

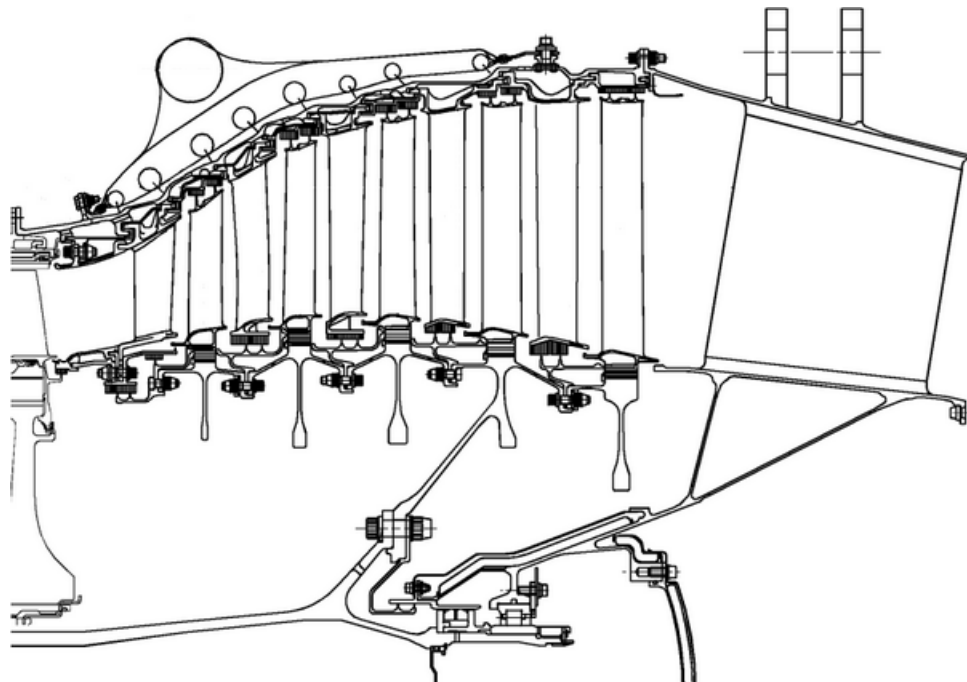

In the second example - which is from a low bypass engine - the inlet guide vane is much bigger than aerodynamically necessary because it serves also as support for the bearing casing.

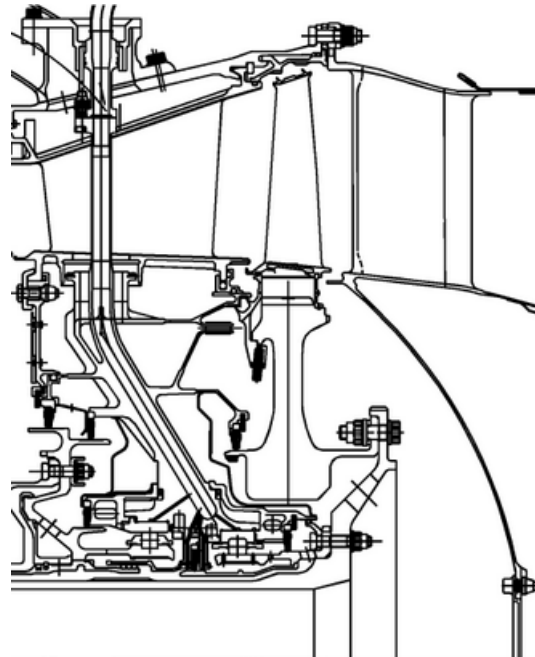

6.7 Inter-duct

The shape of the inner annulus contour is described by a polynomial with given slopes at the inlet and the exit. The outer contour represents a linear area change between inlet and exit station. A strut might be needed for bearing support, its length is specified in percent of the inter-duct length. Entering zero percent for the strut length will produce an inter-duct without strut.

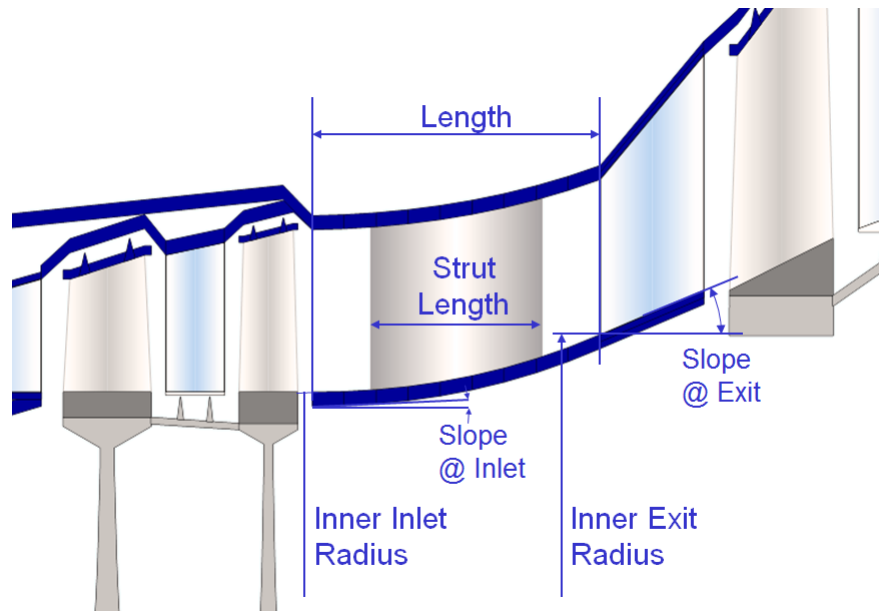

The mass calculation assumes that the duct is manufactured by casting, for example. The struts are hollow and have the same thickness as the inner and outer walls of the flow channel.

6.8 Turbine Exit Duct

The turbine exhaust duct contains struts which represents a bearing support structure and/or a turbine exit guide vane. The cone may end within the exhaust duct or continue downstream. If a nozzle or exhaust diffuser follows the turbine exhaust duct and you want the exhaust cone extend into the nozzle, set the cone length/inlet radius ratio to a value greater than 1.0. Do this if you want to use a plug nozzle or a ring shaped exhaust for a power generation gas turbine.

Using values for the cone length/inlet radius ratio in the range of 0.5...0.8 to 1 is not recommended because the flow can not follow the sudden increase of the area from the cone end to the exhaust exit. Note that the cone end cap is not included in the calculated cone length.

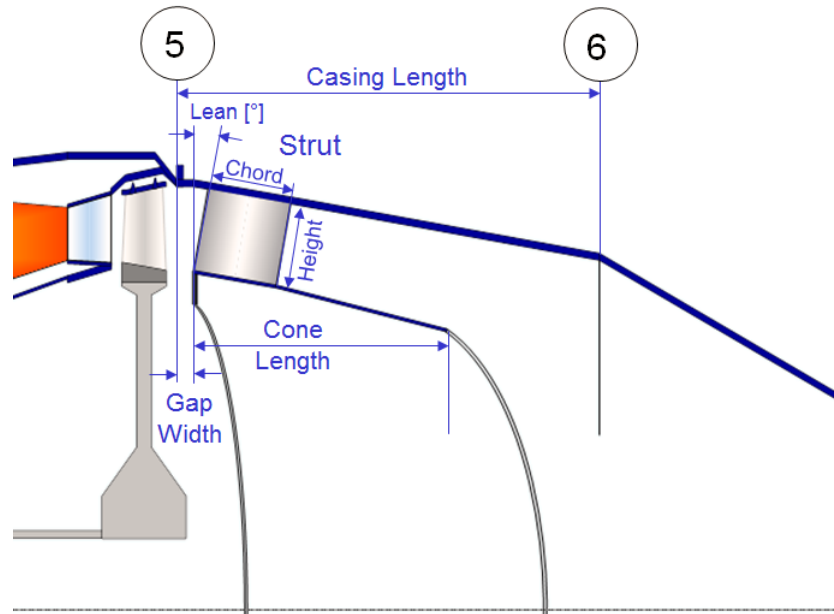

6.9 Bypass

The inner shape of the bypass is defined by two third order polynomials which are joined at the *Flat Point* - there the bypass channel is cylindrical.

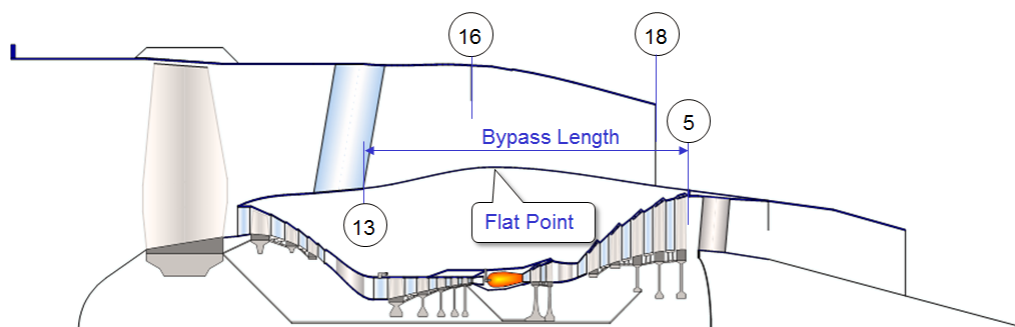

If the thickness of the inner casing is set to zero, then no inner contour is shown and the outer contour of the bypass will be a straight line. Thus you can make the outer casing conical or cylindrical. As you can see from the figure, the bypass nozzle is part of the bypass.

With the VARIABLE CYCLE ENGINE the bypass has a second entrance. The mass of the channel from the compressor inter-duct to the bypass is not considered, neither as part of the bypass nor as part of the duct.



6.10 Mixer

Mixer exit area can be specified directly or it is calculated from the given Mach number in station 64. Note that both A_{64} and XM_{64} are part of the basic input data, they cannot be accessed as elements of station 64.

6.11 Reheat

The reheat system (afterburner) is a pipe with constant diameter. The fuel injectors and the flame holders are located upstream of the reheat system.

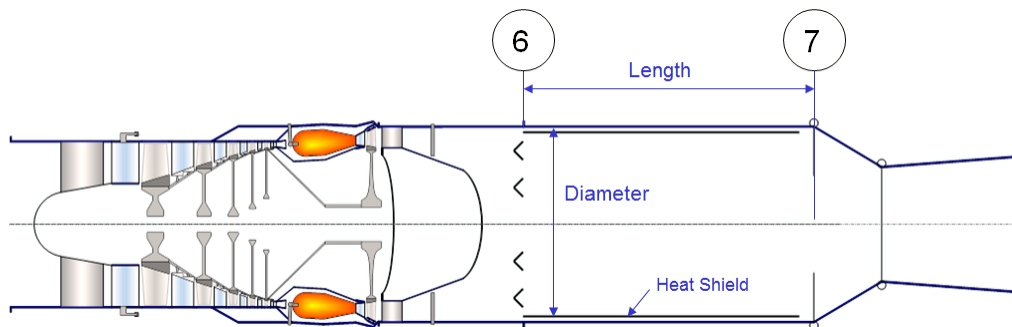

6.12 Exhaust

The core engine exhaust nozzle can be designed in different variants. For jet engines a simple conical or a plug nozzle may be appropriate while for turboshaft engines the exhaust can be configured as a conical diffuser with an inner and an outer wall. Convergent-divergent nozzles are always of the standard nozzle design, extended by a divergent section. Note that the nozzle throat and exit areas are a result of the cycle design calculation. However, the petal angle used for the calculation of the nozzle discharge coefficient is not connected with the geometric nozzle design except for a standard nozzle without cone. Bypass nozzles are taken care of as part of the bypass.

These are the options for the geometric nozzle design:

1a Standard Nozzle, no Cone

The standard nozzle without cone is fully defined by the exhaust area and the petal angle. The petal angle is a cycle calculation input if the [Nozzle Calculation Switch](#) is set to *Standard*. Otherwise the petal angle is calculated from the given ratio length/inlet radius, inlet and throat radius. Note that the resulting petal angle of this calculation has no influence on the nozzle discharge coefficient.

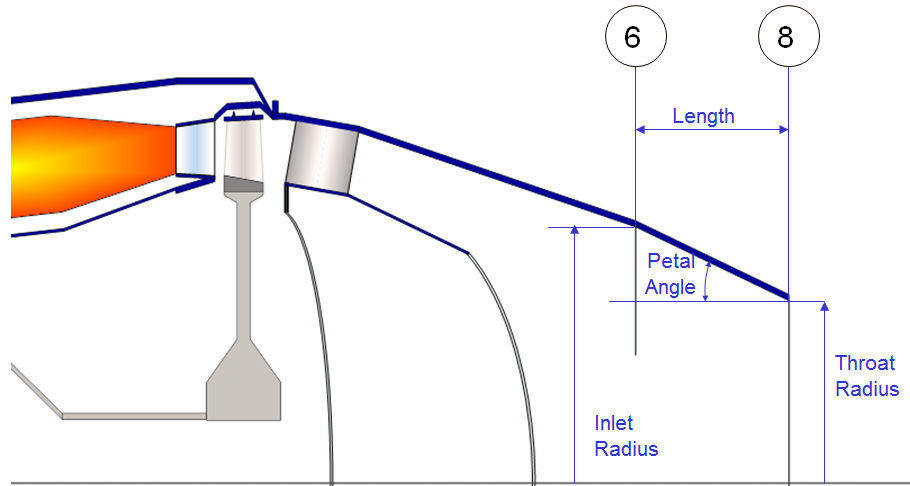

1b Standard Nozzle, With Short Cone

If the cone of the exhaust duct continues within the nozzle, then this creates a nozzle inlet section which is as long as the cone part within the nozzle. The assumption that along the nozzle inlet section there is no flow area change yields the inlet radius for the second part of the nozzle.

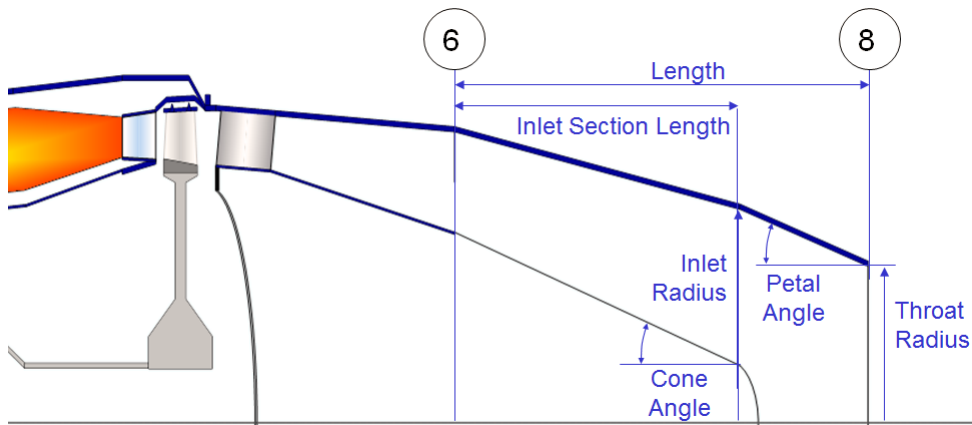

2 Plug Nozzle

The prerequisite of a plug nozzle is that the cone does not end already in the turbine exit duct.

The nozzle cone (the plug) ends either in the nozzle throat (station 8) or continues further downstream. The cone length is calculated from *Cone Length/Inlet Radius* and the nozzle *Cone Angle* (which might be different to that in the exhaust duct). If the cone length calculated from these two values is less than the sum of the inlet section length and the convergent length then the nozzle cone angle is calculated in such a way that the cone ends in the nozzle throat.

If the cone ends in the nozzle throat, but you want the cone to continue downstream of the throat (to get a true plug nozzle), then make sure that the *Cone Angle* is small and the *Cone Length/Inlet Radius* big enough.

The length of the inlet section is specified as a fraction of the nozzle outer radius at its inlet. The flow area at this position is derived from the nozzle inlet flow area multiplied by the *Inlet Section Area Ratio*.

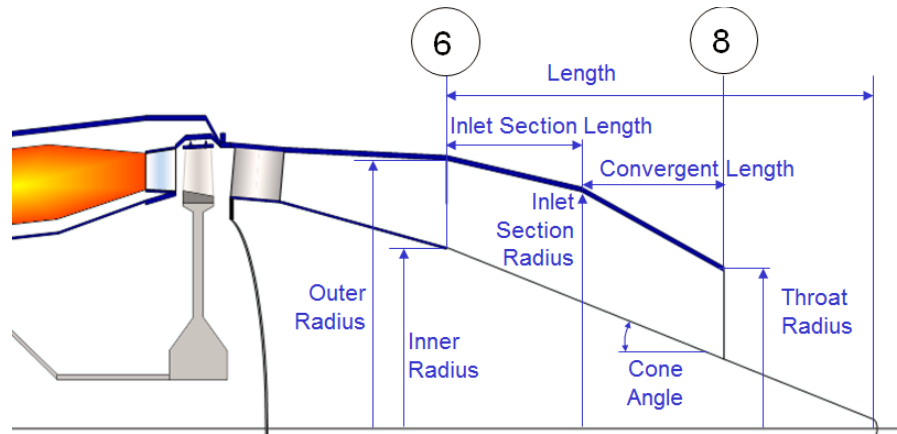

3 Power Generation Exhaust

Gas turbines for power generation need to decelerate the exhaust flow as much as possible because the kinetic energy of the exhaust gas is a loss for the process. A well designed exit diffuser is needed for minimizing the total pressure loss. Note that all pressure losses must be taken into account in the component upstream of the nozzle inlet station because GasTurb 13 uses the correlations for isentropic flow in the exhaust (nozzle).

For this type of exhaust design the cone length sets the total length of the exhaust system; the cone angle can be positive or negative.

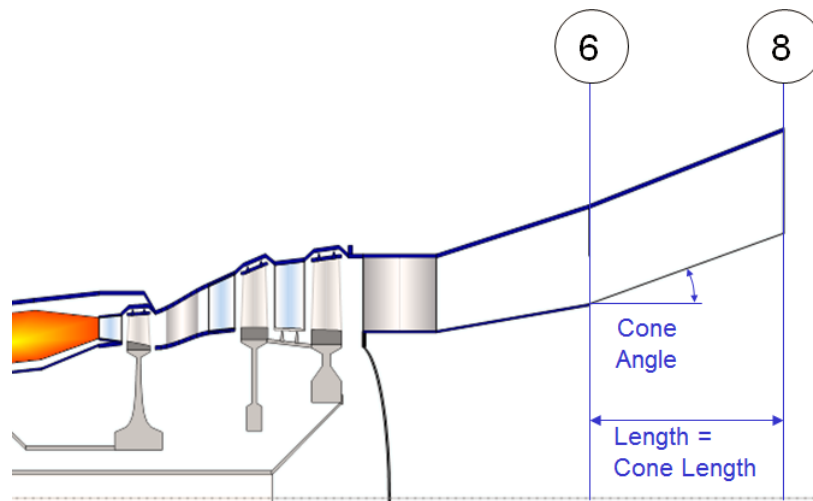

6.13 Intercooler and Heat Exchanger

No geometry calculations are performed for intercoolers and heat exchangers.

6.14 Gearbox

The mass of the gearbox is calculated from the power it transfers. No gearbox design and geometry calculations are performed, the gearbox in the engine cross section is a cartoon.

6.15 Shaft

A shaft consists of a front cone, the middle part with constant diameter and the rear cone. The cone thickness is at the inner radius equal to the thickness of the shaft, at the other end it is only half of the shaft thickness. No stress calculation is done for shafts.

The outer radius of the LP shaft is equal to the smallest bore diameter from all disks of the HP compressor and turbines, minus the shaft thickness.

6.16 Disk Design Methodology

An algorithm which estimates the mass (weight) of disks from axial turbo machines is implemented into GasTurb 13. It must be acknowledged that this disk stress calculation methodology has its limitations. In an actual disk, the local stresses - which are relevant for disk life - depend on countless details which are not yet known in the preliminary design phase of an engine.

The disk design methodology and the stress calculation is fully described in the help system to GasTurb Details 6. In the following sections the integration of this methodology into GasTurb 13 is discussed.

After having calculated a cycle and stored the input data in a file you can examine any of the disks independently from the cycle code with the program GasTurb Details 6. This program is able to read the disk data from the cycle file and can show the distributions of radial and tangential stresses, for example. Moreover, you can view and edit the material database which comes with GasTurb 13.

The disk design speed is a result of the cycle design point calculation, modified by increments which take into account that spool speeds can be higher at other operating conditions than those of the cycle design point.

6.16.1 Geometry

Select either a *Web* or a *Hyperbolic Disk* which has a smooth thickness change between the inner rim and a small web ring just below the outer rim. A *Web Disk* can get the shape of a ring disk when the difference between rim and bore radius becomes small and the bore width is equal to the rim width.

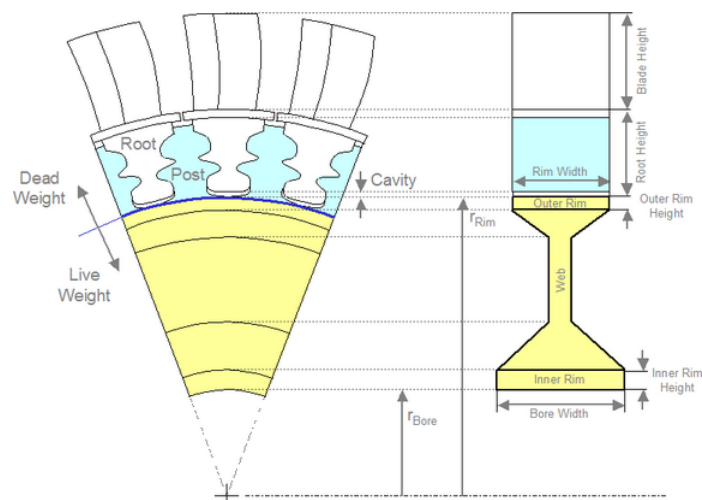

Some of the input data for the disk calculations are normal input quantities, others are a result of the compressor respectively turbine flow annulus design. The lowest permissible bore radius of all disks



of a compressor respectively turbine component is calculated as a fraction of the inner annulus radius at the inlet to the respective component. The relevant input quantity is the ratio *Disk Bore / Inner Inlet Radius* which is found on the *General* input page of the component.

The *Rim Width* is equal to the axial component of the blade chord. Note that the cavity height is ignored when considering the *Root / Blade Height Ratio*.

The disk material can be selected from the drop down list which appears when you click in the last line of the input table on one of the columns. Although the material data is believed to be representative, the characteristics of the actual material may vary from what is contained in the material database.

6.16.2 Temperature

Rim and bore temperature have an influence on the design margin of a disk; Exact values for these temperatures are impossible to get during the preliminary design phase, only first estimates are possible.

For compressors the inner platform temperatures are increasing from the gas inlet temperature (first stage) to the compressor exit temperature (last stage). The temperature gradient from the platform towards the disk center is described with a single number which stands for the temperature difference from the platform to the center point of the disk. The temperatures in the live disk are linearly interpolated between the platform temperature and the imaginary disk center temperature. Besides using adequate numbers for the temperature gradient you can influence the disk temperature employed for the stress calculation with a positive or negative adder.

The temperature distributions within turbine disks are calculated with a more sophisticated algorithm. At first the relative temperature at the rotor inlet is calculated for each stage by applying a factor of 0.9 to the absolute stage inlet temperature. Next the radial temperature distribution is considered which yields as inner platform temperature 90% of the relative rotor inlet temperature. If the turbine is not cooled, then this temperature serves as the anchor point from which the temperature decreases linearly towards the disk center point with a given gradient.

With cooled turbines, the air usually is injected into the cavity in front of the turbine disk with a tangential velocity component. This lowers the cooling air temperature similarly to the main stream gas temperature which is lower in the relative (rotating) system compared to the absolute (non-rotating) system. Dependent on the amount of cooling air and how it is guided to the rotor, the temperature at the live disk rim can be significantly lower than the platform temperature. For taking that effect into account, the anchor point for the disk temperature calculation is placed between the platform temperature of an uncooled turbine and the cooling air delivery temperature (T_3 in case of high pressure turbines). The correlation is a parabola which begins at the platform temperature and decreases with increasing amount of the rotor cooling air until it reaches as minimum the cooling air delivery temperature when its amount is 5%. If more than 5% cooling air is available, then the disk anchor temperature remains at the cooling air delivery temperature.

If a cooled turbine has more than one stage, then two thirds of the total cooling air is led to the first rotor and one third goes to the second stage. If the turbine has more than two stages, then the rest of the stages are regarded as uncooled. Use the temperature adders for adjusting the result if you have better information about the actual disk temperature distribution.

6.16.3 Design Options

With the calculation control variables *Adapt Bore Width*, *Adapt Bore Radius* and *Optimize Disk* you can influence how each disk is calculated. Select the most straightforward calculation option by

setting all three control variables to zero; then all input quantities are taken as they are. However, this leads often to over-stressed or unnecessarily heavy disks.

When bore stress is critical, then you can get a feasible disk shape by automatically adapting the bore width in such a way that the design margin is achieved. This logic is activated by setting *Adapt Bore Width* to 1. Alternatively you can work with a prescribed bore width (*Adapt Bore Width*=0) and adjust the bore radius to get the desired design margin (*Adapt Bore Radius*=1). If both the bore width and the bore radius control variables are equal to one then the bore radius will be set to its lowest permissible value and the bore width is adjusted to get the desired design margin.

<i>Optimize Disk = 0</i>			
Optimization is switched off			
<i>Adapt Bore Width = 0</i> bore width is as given by input		<i>Adapt Bore Width = 1</i> bore width is adapted to the target design stress margin	
<i>Adapt Bore Radius = 0</i>	<i>Adapt Bore Radius = 1</i>	<i>Adapt Bore Radius = 0</i>	<i>Adapt Bore Radius = 1</i>
bore radius is as given by input	bore radius is adapted to the target design stress margin	bore radius is as given by input	bore radius is set to its lower limit

Even with the various calculation options described above it is not easy to find a good lightweight disk design. However, a mass (weight) optimized disk can be found easily with the help of a numerical disk optimization algorithm which is selected with *Optimize Disk*=1. The three standard optimization variables are

	lower limit	upper limit
Outer Rim Height/Rim Width	0.1	1
Web Width/Rim Width	0.15	1
Inner Rim Height/Rim Width	0.2	1

Whether bore radius and bore width are optimization variables or not is controlled by the settings of *Adapt Bore Width* and *Adapt Bore Radius*:

<i>Optimize Disk = 1</i>			
Optimization is switched on			
<i>Adapt Bore Width = 0</i> bore width is as given by input		<i>Adapt Bore Width = 1</i> bore width is an optimization variable	
<i>Adapt Bore Radius = 0</i>	<i>Adapt Bore Radius = 1</i>	<i>Adapt Bore Radius = 0</i>	<i>Adapt Bore Radius = 1</i>
bore radius is as given by input	bore radius is an optimization variable	bore radius is as given by input	bore radius is an optimization variable

As optimization algorithm the [adaptive random search](#) strategy is recommended because it is more robust than the gradient strategy. This robustness costs computation time and therefore the simultaneous optimization of many disks within an extensive parametric design study or in combination with iterations may need much patience.



If you begin with a new engine project and your first disk design attempt leads to over-stressed disks, then select for these disks the optimization algorithm and set both *Adapt Bore Width* and *Adapt Bore Radius* to one. In each case the algorithm will automatically search for a feasible disk shape first and in a second step minimize the disk mass. If the optimization is not able to find a feasible disk then you need to lower the minimum bore diameter or to reduce the disk rim load.

6.16.4 Design Criteria

The most important result of the disk design algorithm is the disk *Design Margin* which is the minimum of the following four margins:

1. Actual Burst Margin - Design Burst Margin
2. Actual Stress Margin - Design Stress Margin
3. Actual Web Stress Margin - Web Stress Margin
4. Actual Burst Speed - Design Burst Speed

No additional safety margins are considered within the program, it is up to you to design the disk for the positive stress margin you consider appropriate (10...30% are reasonable numbers). If the design margin is negative, then the disk is marked as over-stressed in the list output and in the engine cross section the disk appears in a different color.

The *Burst Margin* (in %) compares the ultimate strength of the material (evaluated at the average disk temperature) with the average tangential stress. The disk *Stress Margin* (expressed in %) compares the yield strength of the material at the local temperature with the local von Mises stress. The lowest local *Stress Margin* is presented as output quantity. Moreover, the *Web Stress Margin* (at the web outer diameter, just below the disk rim) is possibly critical. Finally the disk *Burst Speed* - which should be greater than 130...150% of the operating speed - must be checked.

Combined Cycle and Cogeneration



VII



7 Combined Cycle and Cogeneration

The exhaust of a gas turbine contains a lot of energy which can be used to generate steam in a *Heat Recovery Steam Generator* HRSG. This steam can be used for industrial processes, for heating or for driving one or more turbines. Some of the steam can also be injected into the burner of the gas turbine for NO_x reduction and power enhancement. Moreover, steam can be used for cooling the blades and vanes of the gas turbine.

If the steam is used in a power generation plant for driving an additional generator through a steam turbine, then the total electrical power output is increased as well as the overall electric efficiency of the plant. Such a combination of a gas turbine cycle with a steam cycle is called a *Combined Cycle*. If the steam is not used for driving a turbine but for process applications in the chemical industry then we talk about *Cogeneration*.

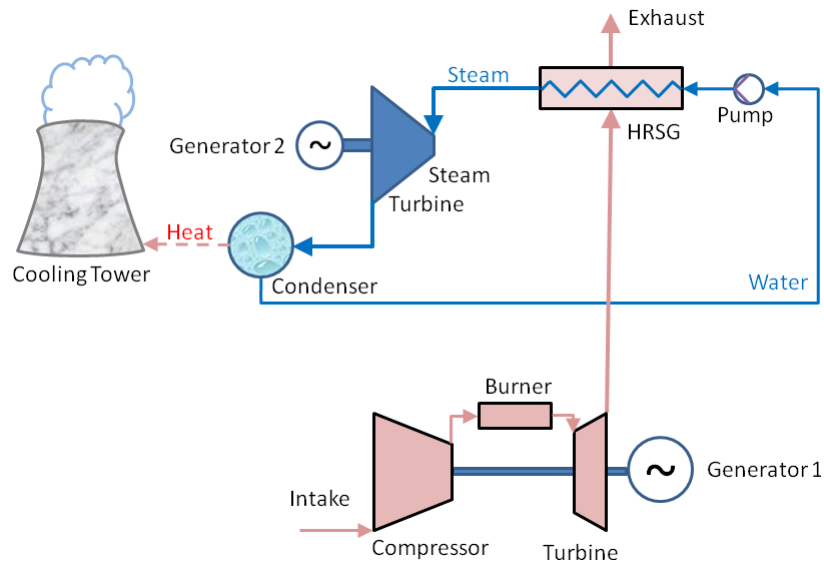

Combined Cycle Schematic

The steam cycle calculated by GasTurb 13 can be viewed in two Mollier diagrams (temperature-entropy respectively enthalpy-entropy).

7.1 Heat Recovery Steam Generator

Heat recovery steam generators can be very complex devices, especially if a high amount of heat is to be recovered from the gas turbine exhaust. The most simple HRSG delivers steam at one pressure only. More heat can be extracted if two or even three steam pressure levels are employed.

7.1.1 Single Pressure

A single pressure *Heat Recovery Steam Generator HRSG* is composed on the water side of an *economizer* for heating the feed water, an *evaporator* in which the water evaporates and a *superheater* for heating the steam to the desired temperature. The temperature of the gas turbine exhaust may be increased in a burner before it approaches the superheater.

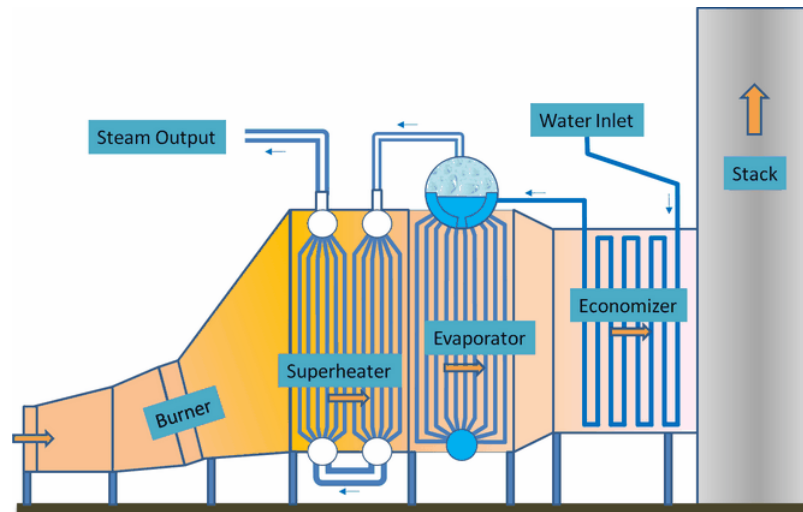

7.1.2 Design

The gas turbine calculation ends with the thermodynamic station 8. The static conditions there are calculated during *cycle design* from the given *Exhaust Pressure Ratio* P_8/P_{arb} assuming $P_{s8}=P_{arb}$.

In a *Combined Cycle* or *Cogeneration* application the gas turbine exit gas mass flow, the total temperature T_8 and the total pressure P_8 define the inlet conditions of the HRSG. The static pressure P_{s8} can be chosen independently from ambient pressure, it is calculated from the given design HRSG inlet Mach number. Note that the design Exhaust Pressure Ratio P_8/P_{arb} for a *Combined Cycle* must take into account the HRSG pressure losses and therefore be higher than the inverse of the *HRSG Design Press Ratio*.

The HRSG should be designed for the unfired mode, i.e. with the duct burner not operating. Both in design and off-design simulations steam temperature and pressure are input values, the amount of steam generated is a result.

Selecting a steam pressure defines the temperature in the *evaporator*.

The theoretical maximum gas side temperature difference available for heat transfer is the difference between the duct burner exit temperature and the evaporation temperature. In real applications there must be a temperature difference between the gas and the water temperature at the water side inlet to the evaporator. This point in the HRSG temperature plot is called the pinch point. $Pinch \Delta T = T_{gPinch} - T_{Evap}$ of practical devices is at least 5 to 15K. The smaller pinch ΔT is, the more surface it takes to exchange the heat.

The gas leaving the evaporator enters the *economizer*. If in the economizer the temperature differential between the gas and the water would be the same as in the evaporator, boiling would tend to occur at the end of the economizer. Boiling in the economizer the water should be avoided, also at off-design operating conditions, because the steam could block the flow. The problem would be water hammer and tube-to-tube differential expansion. Therefore the outlet water temperature of the economizer must be kept several degrees below the saturation temperature. The temperature difference of 5 to 10K between the economizer exit and the evaporator is the *Approach ΔT* .

The figure below shows the nomenclature used on the *Combined Cycle* page of the single point output. Note that you can view the actual temperature plot in the diagram output window after clicking  (*HRSG Temp*).

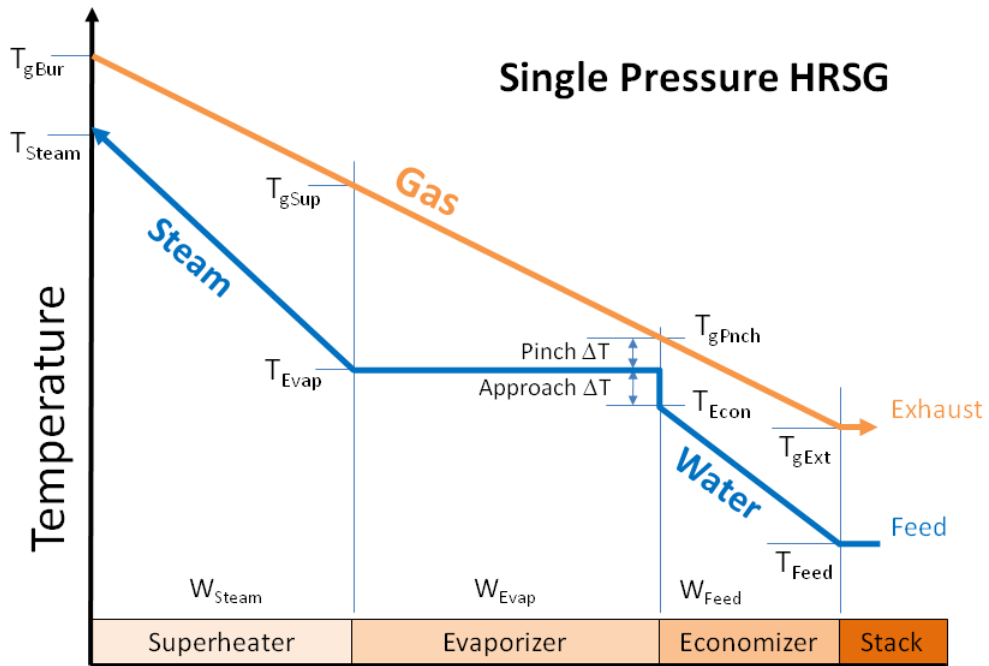

7.1.3 Off Design

During off-design simulations with a HRSG as exhaust system the gas turbine exhaust flow is no longer controlled by the conditions in station 8 where - without HRSG - the static pressure is equal to ambient pressure. The static pressure at the stack exit is now the ambient pressure.

When doing the HRSG design calculation the **effectivenesses** of *economizer*, *evaporator* and *superheater* are determined.

During off-design simulations these effectivenesses are modified by correction factors that allow taking changes in the gas side heat transfer into account. The correction factors are of the form $(W_g/W_{g,ds})^{const}$ with three different adaptable exponents, called *Off-Design Constants* on the *Combined Cycle* input page.

The performance of the HRSG has to be checked unfired and with the coldest ambient conditions. Under these circumstances the gas flow is highest and the gas turbine exit temperature is lowest.

7.2 Steam Turbine

The simulation of the steam turbine and the condenser is an option. Most of the steam turbines used for power generation are condensing turbines which exhaust directly to condensers. There rules the saturation pressure which is well below atmospheric pressure and a function of the cooling medium temperature.

The steam turbine simulation is for a given efficiency, both in design and off-design cases - no turbine map is used.

General Options





8 General Options

8.1 Range Checking

All the input and output values - except the data needed for the scope [More](#) - are checked whether they are in a reasonable range. Actually two ranges are considered: a narrow range (exceeding it causes a warning message) and a wider range which - if exceeded - triggers an error message. If an upper or a lower range border is declared as undefined then it will not be checked.

Default range borders are defined for each engine configuration in the respective [NMS file](#). These default ranges are rather wide because they must be applicable to any problem; narrow default ranges would cause a high false alarm rate. It is a good idea to narrow down the ranges for specific engine simulations because then much more input and output problems can be highlighted by the range checking procedure. Click the  (*Ranges*) button in the *Extras* button group to open the *Set Range Checking Borders* window:

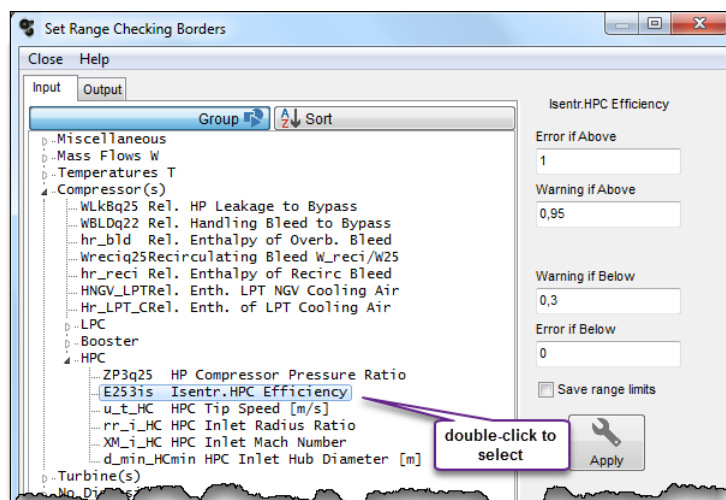

If a value is outside the range given by the low and high range limits then this causes a warning while an error is declared when the value is outside the range defined by the very low and very high borders. Note that neither a warning nor an error message has any influence on the calculation, correcting the value of the responsible input properties is left to the user.

For editing the range borders select a quantity by double-clicking it in the input or output tree view. The present settings of the four range borders will appear in the edit fields. If these settings have been read together with the data, then the box *Save range limits* is checked. Edit the range borders according to your needs. The border values very low and low may be identical; the same is true for the border values high and very high. To make a border ineffective, leave the edit field blank.

You can store the edited range borders together with your data: Check the box *Save range limits* before clicking the *Apply* button. If the box is not checked when the *Apply* button is clicked, then the edited range borders will not be part of the data file when it is saved.

8.2 Composed Values

8.2.1 Definition

An introduction into composed values has been given in the [Getting Started](#) section. Here some more complex options for defining composed values are explained.

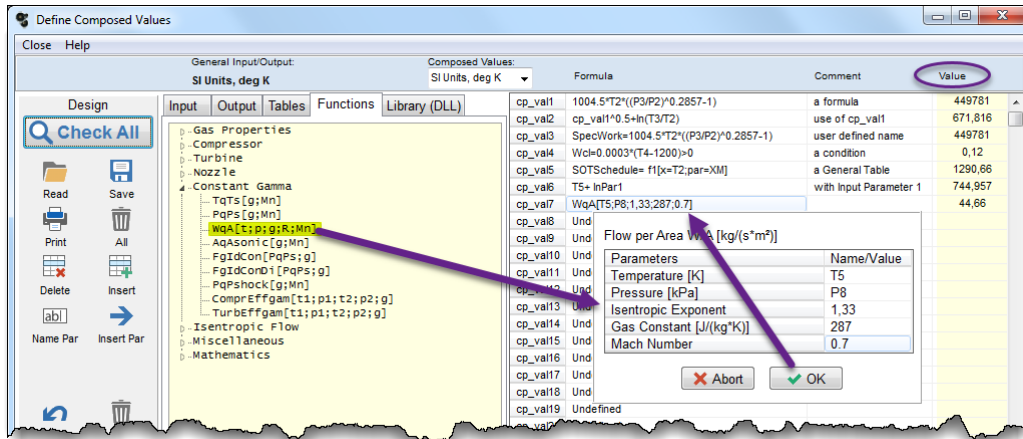

All input and output quantities that are selectable for the definition of composed values are presented in the notebook on the left side of the screen. Note that the *Tables* page is empty as long as no *Table* is defined.

The first eight characters in the parameter lists are the *short names* that are used in formulas. The availability of names depends on your option selection. If *Turbine Design* is switched off, for example, then you cannot use velocity diagram data of the turbine in composed values since they will not be calculated.

199 composed values can be defined employing the mathematical operations +, -, *, / and ^ for exponential expressions. You can use parenthesis in your definitions, the natural logarithm **ln(x)** and the absolute value **abs(x)** of any quantity as well as the trigonometric functions **sin(x)**, **cos(x)**, **tan(x)**, **arcsin(x)**, **arccos(x)** and **arctan(x)**. Furthermore you can use the operators < and > after an expression, followed by a single number. If one of these operators is there, then the result of the expression will be checked if it is lower respectively higher than the number following the < or > symbol. This option can be handy with a formula that describes the amount of cooling air, see for example the formula for *cp_val4* in the above image, which yields only positive results for *Wcl*.

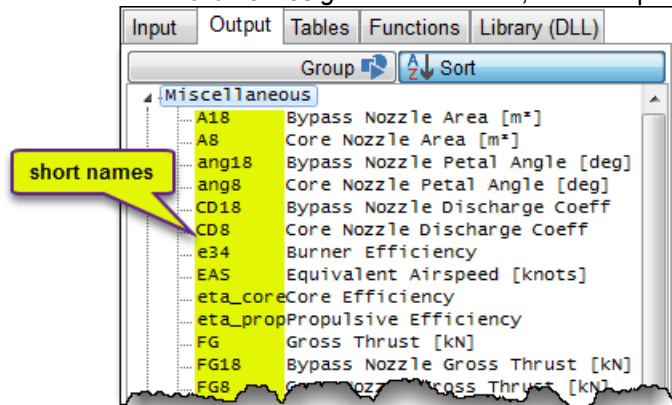

Any composed value can be used as a maximum or minimum *limiter* during off-design simulations. With this approach quite complex control schedules can be modeled.

Use the generic *input parameters* to make a composed value a function of this parameter. *Input Parameters* can be handy in combination with parametric studies and iteration targets.

The units employed when evaluating the formulas is independent from the *units* that are used for the other data in- and output. Thus switching the system of units in general does not invalidate the composed value definition.

It is a good idea to place the definition of the composed values that are employed as iteration targets and also the user defined limiters at the top of the composed value definition list. This is not a stringent requirement, however, it will speed up the calculation.



8.2.2 Using Design Cp_Val's During Off-Design

There are four independent sets of composed value definitions: for *design*, *off-design*, *transient* and *for test analysis*. The different sets of definitions are required because many output properties are only available while the specific simulation task is performed.

Normally all the four sets of composed value definitions are independent from each other. However, it is possible to employ calculation results from the cycle design point during off-design simulations. With this feature you can calculate during off-design the shaft power in relation to the design shaft power, for example.

For using this option you need to define during cycle design composed values with [user defined names](#) that begin with **&**. If you want to use the cycle design shaft power during off-design, then define any of the cycle design composed values as

```
cp_val5 &DesPower=PWSD
```

Here the fifth composed value is used, but any other value would do also.

During the cycle design calculation this composed value (cp_val5) will be evaluated and the result will be inserted at the top of the off-design composed value list. If the design point shaft power is 2320, then you will get as the first off-design composed value definition

```
cp_val1 &DesPow=2320
```

If you look for the operating point with 50% of the design shaft power then define as additional off-design composed value

```
cp_val2 RelPow=PWSD/&DesPow
```

Choose an input quantity that influences the shaft power delivered as iteration variable and *RelPow=0.5* as iteration target.

You can use the transfer of cycle design calculation results to off-design composed values also as part of an *Engine Model File* that is to be used with a [computer deck](#). Note that computer decks are restricted to simulations with the [scope](#) "Performance", however, they also accept *Engine Models* that were created with the scope "More". In this scope among other quantities the engine mass and dimensions are calculated. If you need to know the engine mass and dimensions in your computer deck, then transfer the cycle design results to the off-design composed values. From within the DLL these can be evaluated with the function *GetOutputValue* using as call parameter the [short name](#) of the composed value (*cp_val1*, *cap_val2* ...).

8.2.3 General Tables

What are General Tables for?

A general table describes numerically a function with two parameters. You can use such a table for calculating additional output values and for modeling special correlations. For example, you can define a table which contains reheat efficiency as a function of reheat pressure P_{s64} and bypass ratio BPR. The value read from this table would be used as an iteration target during off-design calculations with the input value for *Reheat Design Efficiency* as iteration variable. If you use one of the generic [input parameters](#) as parameter in the table then you can select between lines in the table by setting the corresponding input parameter in a parametric study, for example. Last but not least you can use the [general table as limiter](#) within the control system simulation.

You can employ up to 20 tables simultaneously which you can enter manually or read from a file.

How to define a General Table

Click in the *Composed Value Definition* window  (*Tables*) to go to the *Table Editor* window. If the *Input* and *Output* tabs are not visible then click the  (*View/Hide*) button.

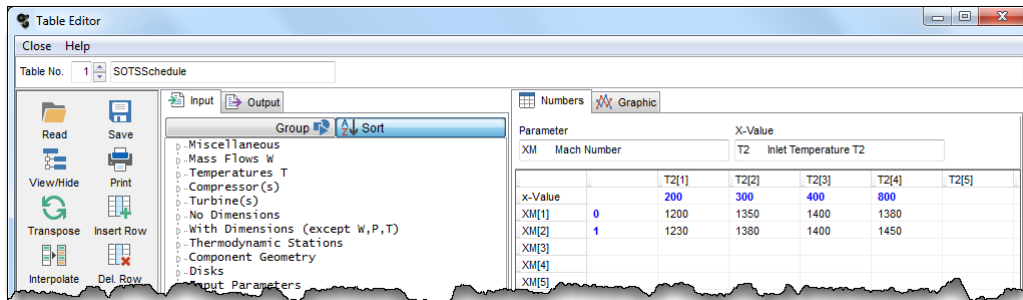

To define a new table, set the table number first and then drag from the tree view a property as *X-Value* and optionally another property as *Parameter*. Furthermore you should enter a *Table Header* which describes the value to be read from the table. Next go to the *Numbers* sheet and enter your numbers for x-value and parameter into the grid. For checking your input click the *Graphic* tab. Note that both the x-values and the parameter values must increase monotonically in the table.

After having defined one or more general tables you can select these in the *Composed Value Definition* window by double clicking them. Note that you can not combine table reading with any other operator. The *General Tables* are also offered as maximum limiters in the [schedule definition window](#).

The units that are used for reading the table and for the result depend on the use of the table:

- If the table is part of the composed values then the units from the composed value definition window are employed.
- If the table originates from the *Schedule Definition* window then the units of the main input window are used.

A *General Table* cannot be used simultaneously as a control schedule and as a composed value.

8.2.4 Pre-Defined Functions

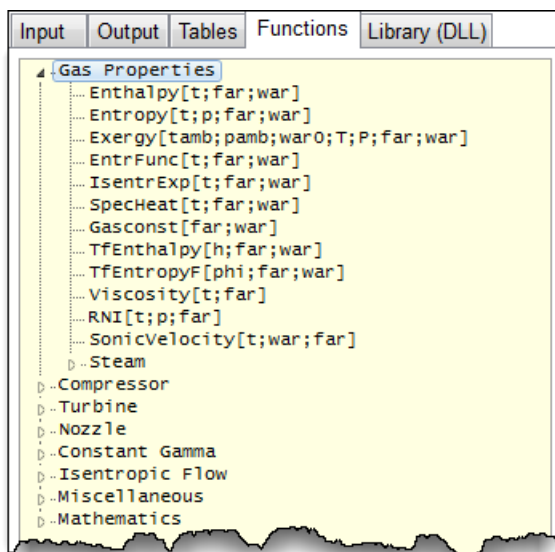

There are many pre-defined functions selectable as composed values. Functions are selected by double clicking them or by dragging them from the list to the composed value definition grid. Only one function is allowed per line, the function name may be preceded by a [user-defined name](#).

You can edit the function call directly in the formula grid or in the special function call grid that opens when you double-click a line with a function call.

Most of the functions are calling the procedures that are used for the cycle calculation and in these procedures the gas is modeled as a [half-ideal gas](#). An exception is the *Constant Gamma* group which contains formulae as found in many textbooks with constant isentropic exponents.

With these functions you are not able to reproduce the cycle results except you know a properly averaged value for the isentropic exponent.



In the *Mathematics* group there are functions like **if a>b then x else y** which enable you to write conditional expressions.

8.2.5 Input Parameter

For use with [composed values](#) or with [general tables](#) there are 99 generic *Input Parameters* *InPar1...InPar99* available. Use these parameters to make composed values a function of an input quantity or to select from several correlations stored in a single general table. The advantage of using an input parameter in the definition of a composed value is that you can modify the composed value via the standard data input without redefining the formula.

Composed values may be used as targets in a user defined iteration. If a composed value employs an input parameter you can perform a parametric study in which the target of the iteration is a function of the input parameter.

Another use of input parameters is within batch jobs. Make any composed value an input parameter, then you can use the input parameter for describing a group of points, for example.

Note that input parameters are only used with composed values and general tables and nowhere else in the calculation. As long as no input parameters are employed with the composed value and general table definitions they will not be offered as input quantities. If you need to use input parameters, then first define the composed values and second make your input for the input parameters.

The default [short and long names](#) of the input parameters are

```
InPar1  Input Parameter 1
InPar2  Input Parameter 2
...
InPar99 Input Parameter 99
```

In the composed value definition window you can replace the default long name by a description that makes sense in the context of your simulation task. Note that the length of the long name must be greater than eight characters.

8.2.6 Userdefined Dynamic-Link Libraries (DLLs)

Some calculations performed by means of composed values may become complex or even impossible due to the required mathematical functions (e.g. calculation of chemical reactions for emission prognosis). Others may rely on large databases, which cannot be easily fed into the program. Therefore, in GasTurb 13, the user can include self-written dynamic-link libraries (DLLs) into the calculations. They are accessed as composed values in the projects, comparable to other formulas. This way it is possible to include complicated calculations and also those which cannot be implemented with simple composed values or general tables.

Two files must be generated by the user to use this feature. They must be written specifically for GasTurb and have a specific interface (dll-file). The interface must be documented and defined in a separate ini-file. It provides all the information needed by GasTurb to call the dll-file and display the function descriptions to the user. Detailed information on the [dll](#) and [ini](#) files are given in the sections below.

GasTurb 13 comes with one sample dll-file, including Pascal (programming language) source code, and one associated ini-file. In this file a simple calculation of kerosene emissions is implemented. These files can be used as starting point for the users own implementations. The interface for this sample appears in GasTurb as shown in the following picture.

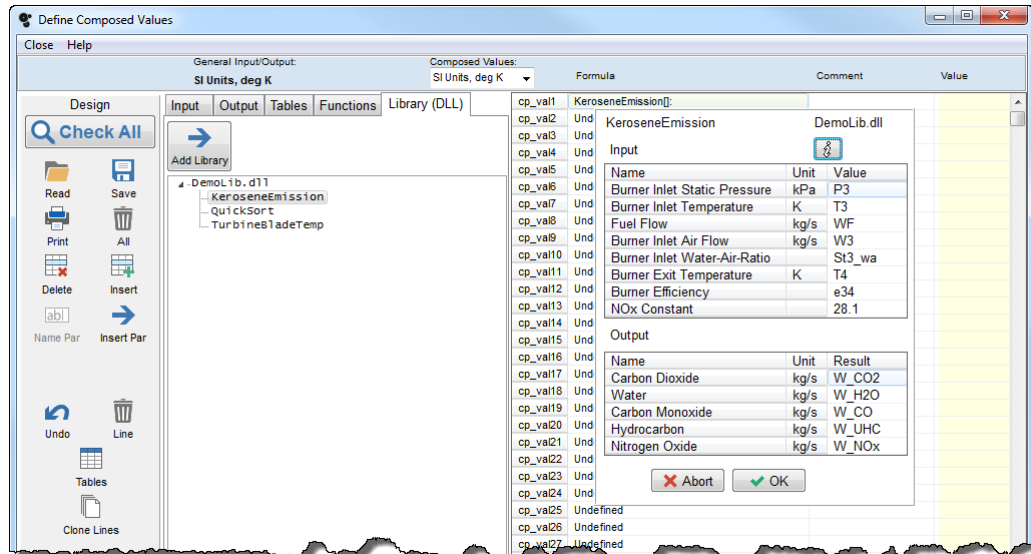

The dll-file and associated ini-file must be stored in one and the same directory, which can be either the GasTurb.exe-path or the path of the GasTurb cycle/model file. They are then automatically displayed in the program. If the dll cannot be loaded, an error message will appear in the *Library* tab sheet of the *Composed Values* window.

Note that the dll- and ini-file are not saved as part of the GasTurb cycle or model files. They must therefore be transferred together with the GasTurb file they are used in, otherwise the model cannot be run and an error occurs.

8.2.6.1 dll-File

In GasTurb 13, up to 10 DLLs can be used with each containing up to 5 different procedures. Each procedure must possess exactly 10 input parameters and 20 output parameters. If less parameters are needed, placeholders must be used. The procedures in the DLL must be named "Procedure1", "Procedure2", ..., "Procedure5". The interface consists of 10 input parameters as single floats, followed by 20 variable output parameters as single floats, followed by one variable parameter for an error code as integer. The following code sample shows an implementation in Pascal.

```
procedure Procedure1 ( P3, T3, WF, W3, war3, T4, e34, cNOx, x9, x10 : real;
  var y1, y2, y3, y4, y5, y6, y7, y8, y9, y10,
    y11,y12,y13,y14,y15,y16,y17,y18,y19,y20 : real;
  var ErrorCode : integer);                                stdcall;
```

8.2.6.2 ini-File

The ini-file contains all the information that GasTurb 13 needs to access the dll-file. The ini-file is a simple text file with a specific structure that GasTurb 13 reads and displays to the user as description of the DLL. The ini-file has several sections, which contain specific information and properties. In the following, the sections with their associated properties are listed and explained. Text contained in the ini-file appears **bold**, the rest are explanations.

```
[General]
DLLName=<dll-file name>
[Procedure1] .. [Procedure5]
ProcedureName=<name of the procedure>
Help=<short explanatory text>
[Input1] .. [Input10]
Name1= .. Name10=<name of the input value>
Default1= .. Default10=<default name or default number> if this is a short name of
  a GasTurb-value, then this will be automatically inserted as default
```



```
Unit1= .. Unit10=<abbreviation of the unit>
Min1= .. Min10=<a lower limit value> if the input value is smaller than this value,
then a warning will be issued
Max1= .. Max10=<an upper limit value> if the input value is higher than this value,
then a warning will be issued
[Output1] .. [Output10]
Name1= .. Name20=<name of the output value>
Default1= .. Default20=<default name> this short name of 2..8 letters will be used
as a default name for the output parameter in GasTurb
Unit1= .. Unit20=<abbreviation of the unit>
Min1= .. Min20=<a lower limit value> if the output value is smaller than this value,
then a warning will be issued
Max1= .. Max20=<an upper limit value> if the output value is higher than this value,
then a warning will be issued
[ErrorCodes1].. [ErrorCodes10]
Value1= .. Value10=<an integer value> this value is assigned to an error code
returned by the dll
Comment1= .. Comment10=<short explanatory text> this text is shown when the dll
returns an error code with the associated value
```

A sample of an ini-file with one procedure is shown below. Note: For the full sample file, refer to the GasTurb 13 installation. Here, only the first two input values, output values and error codes are shown.

```
[General]
DLLName=DemoLib.dll
[Procedure1]
ProcedureName=KeroseneEmission
Help=calculates emissions of kerosene
[Input1]
Name1=Burner Inlet Static Pressure
Default1=P3
Unit1=kPa
Min1=0.1
Max1=10000
Default2=T3
Name2=Burner Inlet Temperature
Unit2=K
Min2=200
Max2=3000
...
[Output1]
Name1=Carbon Dioxide
Default1=W_CO2
Unit1=kg/s
Min1=0
Max1=1000
Name2=Water
Default2=W_H2O
Unit2=kg/s
Min2=0
Max2=1000
...
[ErrorCodes1]
Value1=0
Comment1=Processed
Value2=10
Comment2=Inv. Output
...
```

In most cases, not all 5 procedures with their respective 10 input values, 20 output values and 10 error codes are used. Only the used procedures and their values must appear in the ini-file. This stands in contrast to the dll-file, where placeholders must be used.

8.3 Iterations

8.3.1 Design

Click  (*Iterations*) in the *Additional* button group to define an iteration system with up to 99 variable and target values. Have a look at the following example which deals with a cycle design calculation for a TURBOJET:

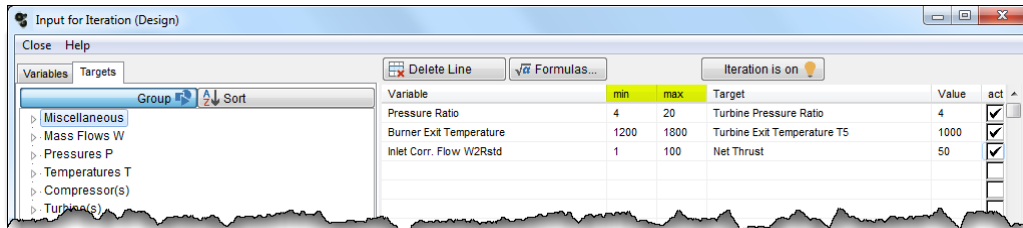

For each of the variables a reasonable range must be specified by setting min and max values. If the range is too narrow, then by accident the solution is excluded and the iteration will fail to converge. A very wide range causes also problems, since the cycle cannot be evaluated with extreme combinations of pressure ratio and turbine inlet temperature. Moreover, a big range for the iteration variables leads to a less accurate result.

8.3.2 Off-Design

Any off-design calculation requires an iteration with several variables. The standard off-design iteration setup, which is hard coded in the program, depends on the engine configuration and the simulation problem (steady state, transient and with inlet distortion). For steady state simulations you can view the variable names, the iteration targets and the estimated variable values in the *Off-Design Input* window:

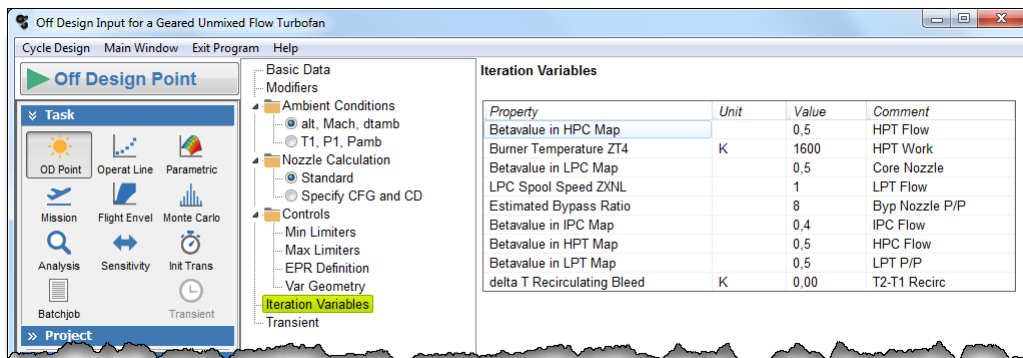

You can define additions to the standard iteration setup as the following example shows:

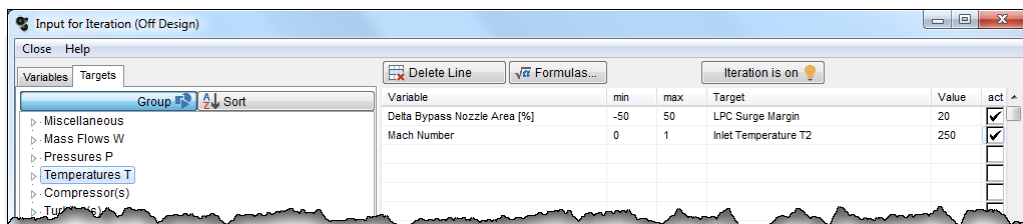

Be careful when defining such additions to the standard iteration scheme: you can easily create an unsolvable problem, and the iteration will fail to converge. In such a case the [Convergence Monitor](#) may help detecting the cause of the problem.



8.3.3 Condition

To define a *Condition*, click the  (*Condition*) in the *Additional* button group. A condition is a special case of an iteration. While in a normal iteration the *Iteration Variable* can have any value, here only selected values are considered.

This option can be used, for example, to switch between several customer bleed locations. The variable is the *Rel. Enthalpy of Overb. Bleed* which is either 0.6, 0.8 (two inter-stage compressor bleeds) or 1.0 (compressor exit bleed). The *Condition* is that *Bleed Air Pressure P_{bld}* is greater than 800. This is how the *Condition* input window looks like for this example:

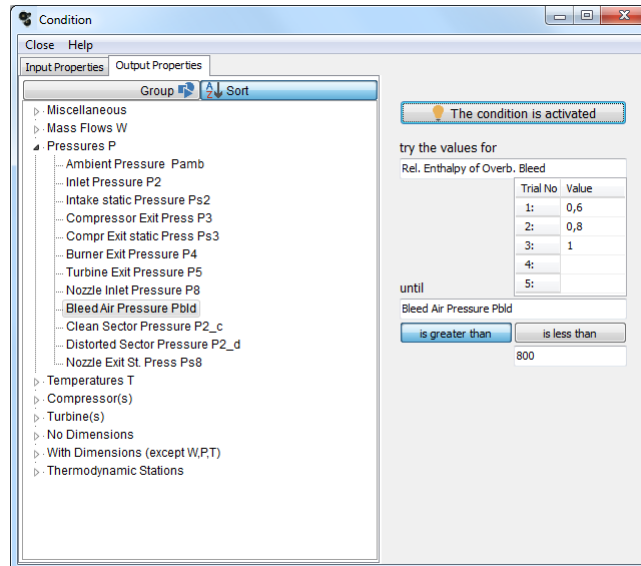

The calculation begins with *Rel. Enthalpy of Overb. Bleed* set to 0.6. The solution for this input is checked whether it fulfills the condition *Bleed Air Pressure P_{bld}* > 800. If this condition is not fulfilled, then *Rel. Enthalpy of Overb. Bleed* is set to 0.8 and the calculation is repeated. If also with this setting the bleed pressure is not sufficient then the final value for *Rel. Enthalpy of Overb. Bleed* is tried. The calculation is finished as soon as the condition is fulfilled or the last defined trial value has been tested.

8.4 Export of Data

8.4.1 Export to Excel

From several windows you can select to export your results to Excel[®]. The first step required for that is to initialize the export process which means that you have to select the data to be exported to Excel.

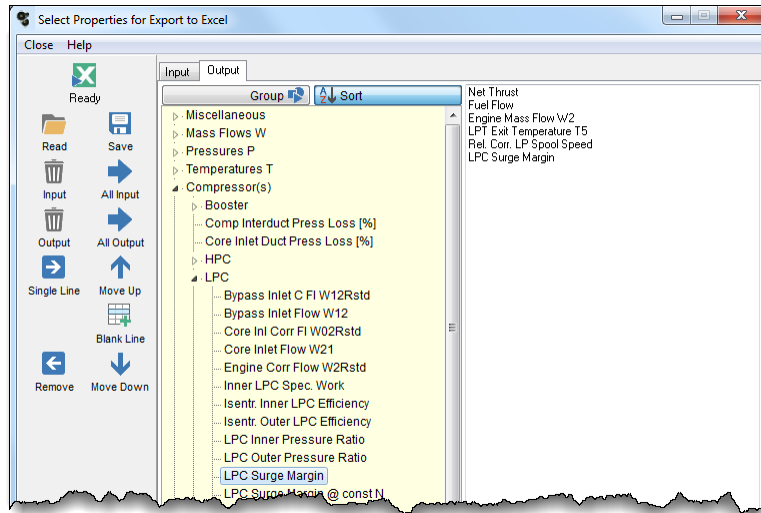

To select a property for export double click it in the list or select it and then click *Add Single Line*. To remove a property from the export list select it and click *Remove Line*. Note that you can rearrange the properties that you have selected for export with the *Move Up* and *Move Down* buttons.

When you click  (*Initialize*) the export selection window will close and Excel shows up. Now you are ready to export your data which in some cases means that the calculation will be repeated. From within GasTurb 13 you can specify the top left cell where the job headline or the first property will be written to the Excel sheet. Be sure to save your spreadsheet before overwriting it with new data.

After you have opened the Excel program from GasTurb 13 there is a connection between GasTurb 13 and Excel. If you no longer need this connection then do not close the Excel program directly, click the  (*Disconnect*) button instead.

Alternatively to exporting your data to Excel you can write them to a file in Excel format by clicking  (*Save to Excel*). Moreover, you can [export your data to an ASCII file](#).

8.4.2 User Defined File Content

You can direct the output of parametric studies, operating lines, Monte Carlo studies and optimization to a file which you can later read with GasTurb or other programs. A pure text file (ASCII file) will be created with the [short names](#) as headline. First you have to select the quantities you want to write to file, click the  (*Define*) button for that.

Select from both the input and output quantities:

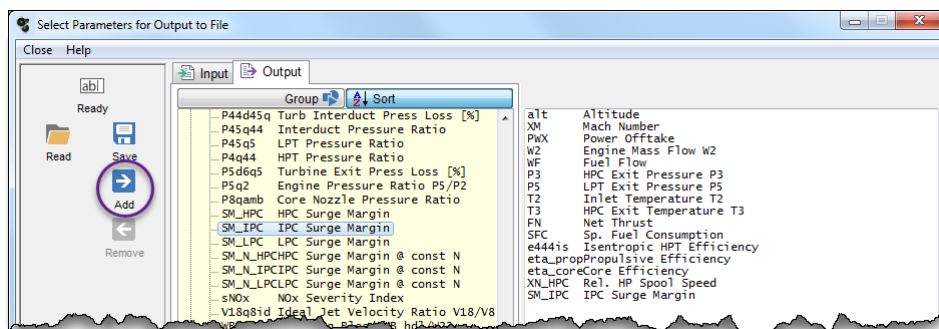

After done with the output parameter selection, click the  (*Ready*) button.

Alternatively to writing to a text file you can [export your data to Excel](#).



8.4.3 Maps

Customer decks derived from GasTurb 13 need as input the compressor and turbine maps which have been scaled in such a way that they fit to the cycle design point. You can write a file with all scaled maps after clicking the  (Save Maps) button in the *Maps and Connections* button group in the *Off-Design Input* window.

8.5 Batch Mode

The Batch Mode is accessible from the *Cycle Design Input* window and from the *Off-Design Input* window. Depending from which window the batch mode is called it will run in cycle design or in off-design mode.

8.5.1 Batch Job Nomenclature

You can run the program in batch mode which means that you use a file with the input for running many cycle points in sequence. In a batch input file - which you can [create](#) from within GasTurb 13 or with any text editor - the following conventions must be followed.

There are several different types of input data, and each type of data is described by its keyword. *Keywords* are on dedicated lines and embraced by [and]. The following keywords are defined:

[Single Data]

- On each line which follows this keyword there is one input quantity.
- First item is the [short name](#), followed by = and input value. Note that the short name is case sensitive.
- After the value there might be an optional comment which begins with //

[Composed Values]

- On each line which follows there is the definition of a composed value
- Any previous definition of the composed value will be overwritten by the new input.
- After the short name of the composed value a colon must follow which separates the short name from the formula

[Iterations]

- A single iteration is defined on two lines: the first line contains the variable information and the second line the target information
- The variable name is a short name of an input quantity
- The values for the minimum and the maximum limit of the variable value must be separated by a semicolon
- The target name is a short name of a calculated quantity
- The number of active iterations is given implicitly by the lines following the [Iteration] keyword. If no iteration definition follows the keyword then all iterations are switched off. If you have four iterations active in point n, for example, and want to switch off one of them for point n+1 then you enter for this point all the three active iterations formula

[Transfers]

- A single data transfer ([Output=Input](#)) is defined on two lines: the first line contains the name of the output quantity to be transferred and the second line the name of the input quantity to which the value of the output from the previously calculated point will be written.
- The output name is a short name of a calculated quantity.

- The input name is a short name of an input quantity.
- The number of active data transfers is given implicitly by the lines following the [Transfers] keyword. If no data transfer definition follows the keyword then all data transfers are switched off. If you have four transfers in point n, for example, and want to switch off one of them for point n+1 then you enter for this point all the three active transfer definitions.

[Limiters]

- A limiter is defined and switched on/off on this line
- The single value limiter setting is the number following *Setting=* after the opening curly brace {
- After the number a semicolon must follow
- After the semicolon either the word *Off*, *On* or *Sched* sets the status of the limiter
- Finally the closing curly brace } finishes the limiter input.
- Example for a limiter setting input line:
MAX Spool Speed NH [%] {Setting=97; On}
- If a **control schedule** is employed then the single value limiter setting input will be ignored. Switching the schedule on is achieved by using **sched** instead of **on**.
- Example for a scheduled limiter setting input line:
MAX Spool Speed NH [%] {Setting=97; Sched}

[Operating Line x Points Stepsize Y]

- An operating line begins with a max power point.
- x partload points follow.
- The NH stepsize (respectively T7 stepsize for afterburner operating lines) is y.
- This keyword concludes the input, the calculation begins.
- After the calculation of the last partload case the iteration variables of the first point are restored.

[Calculate]

- This keyword concludes the input for a point.
- After this keyword the input for a next point may follow. If single data follow then the keyword [Single Data] is not required.

8.5.2 Batch Job Editing

Creating a new batch job or editing an existing batch job is easy: Click in the *Batch Processing* window the **ab** (*Edit*) button and the *Batch Job* window will open.

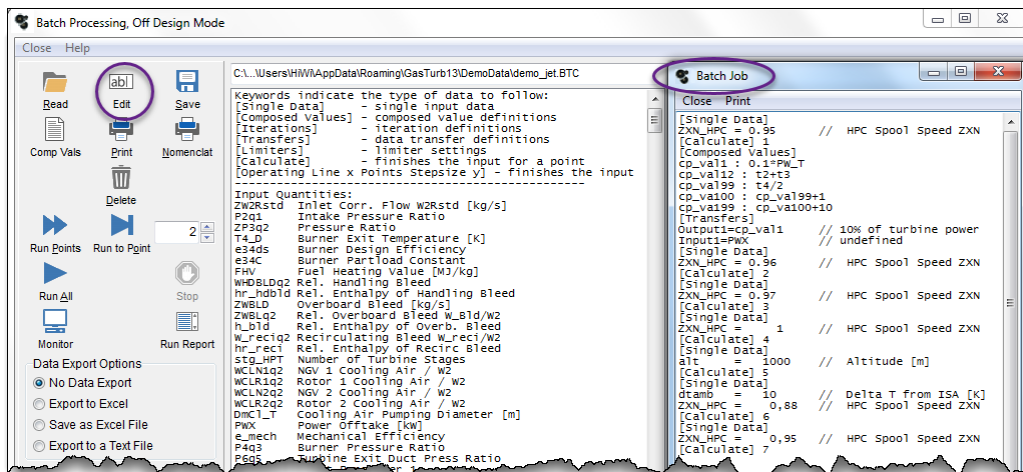



Left to the editor you see a list with the valid **keywords** and input quantities. Double-clicking a line in this list will introduce this line in the correct format into the editor window at the position above the cursor. Do not forget to complete this line with the numbers of your case study.

You can print the list with all input quantities and produce your batch file with any standard text editor. Be careful: the short names are case sensitive!

Note that the validity of many input data depends on the selected calculation option. You will get an error message if you use input quantities that do not belong to the selected option. This happens, for example, if you include in your batch file an input for *polytropic efficiency* while you have selected the option with to use *isentropic efficiency* as input.

Composed value definitions employ a colon after the **short name** of the composed value. Do not remove this colon!

Note that after closing the *Batch Job* window all lines that contain the *[Calculate]* keyword will be numbered automatically. After editing a batch file you should write it to file, otherwise you will lose it as soon as you close the *Batch Processing* window.

Below is a short batch file listed which contains three cycle design points of a TURBOJET:

```

alt      = 1000      // Altitude
XM       = 0.0       // Mach Number
T4_D     = 1400      // Burner Exit Temperature
ZP3q2    = 15        // Pressure Ratio
[Calculate] 1
alt      = 0         // Altitude
[Composed values]
cp_val4  : T4*5/9
[Calculate] 2
alt      = 500       // Altitude
XM       = 0.5       // Mach Number
[Iterations]
Variable3=ZP3q2 {min=5; max=100}
Target3  =T3        {value=800}
[Single Data]
dtamb    = 10        // Delta T from ISA
[Calculate] 3

```

8.5.3 Running a Batch Job

After closing the **batch job editor** you will see your batch job listed in the left part of the window. Now you are ready to run the batch job, and you have three options:

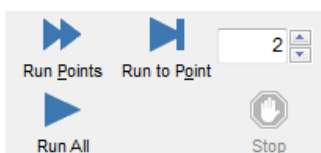

Run all points in one go, the output will be sent to an Excel sheet. This option is only available after Excel is initialized.

Run point by point with standard output

Run to point number x in your batch file listing is, the standard output will be provided

As mentioned above: before you can select the first option you must have **initialized Excel** which implies that you select the quantities that you want to see in the Excel sheet. Do not close Excel before you are done with all your data export work.

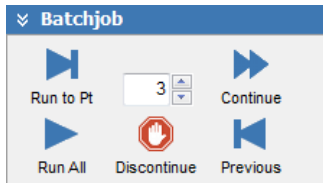



After running the batch job you get a report which is shown to the right of the batch input list. Any problems encountered during the calculation are listed there.

If you do not run all points in one go, then you get the single point output window. There you find on the top right the *Batchjob* button group with which you can decide what to do next.

8.6 Graphics

8.6.1 General

The figure shows the graphical output from a parametric cycle design point study with two parameters. For selecting new plot parameters, do not close the window - because that leads you to a new parametric study - click  instead. If you vary only one quantity in your parametric study then you can use in the figure up to **four y-axes**.

GasTurb 13 has selected in the example below the scales for the x- and y-axes automatically in such a way that all the numbers are round and look nice. You can easily modify the scales after clicking  (Axis). In this way, you can produce a series of plots with the same scale. Note that the program will accept your input for a different scale only if your wish implies round numbers for the x and y-axis. The number of contour lines will be selected automatically using the same algorithm as for the axes. You can [modify the contour line parameters](#) in a special window.

You can also zoom in to the details of this graph using your mouse. Press the left button and hold it down while moving the mouse. Enclose with the rubber rectangle the region you are interested in and release the button to initiate repainting the figure. With a click on the right button of your mouse you get a pop-up menu with the option *Reset Scales* which will zoom out to the standard scaling again. If the range of values is very small, an appropriate number will be subtracted from the values and noted separately at the axis. If, for example, all values are between 32000.3 and 32000.4 the scale will begin with 0.3 and end with 0.4. Near to the axis the string +32000 will be written.

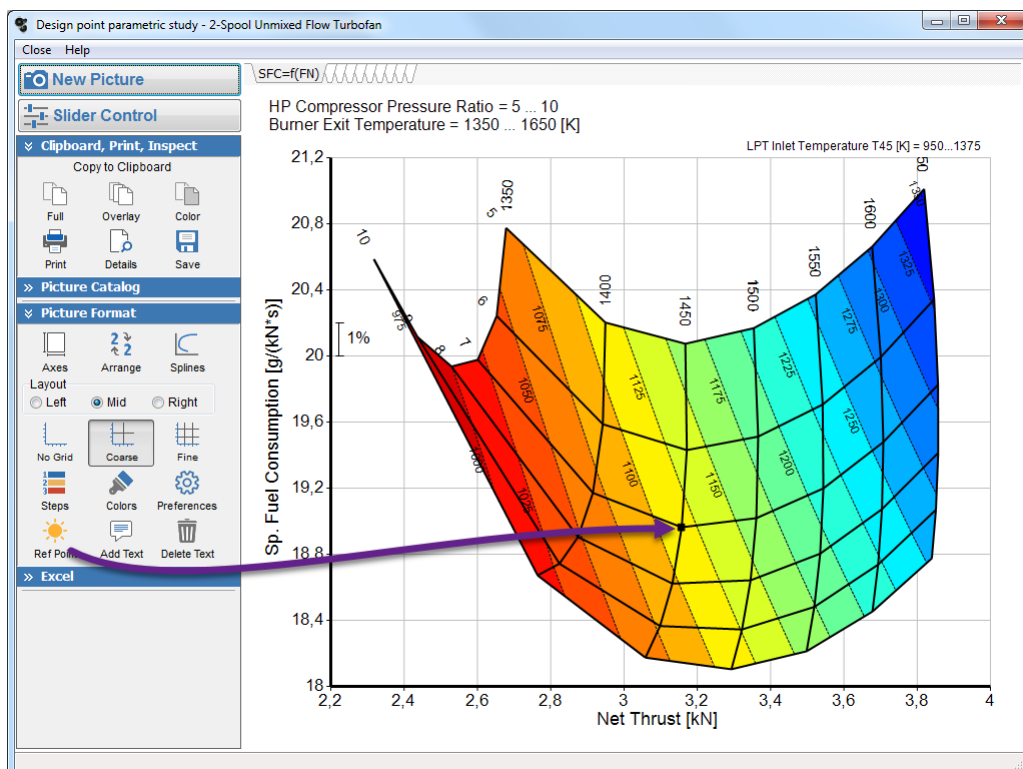



Click ☀ (Ref Point) to toggle between showing and hiding the reference point. This is the little black square which is consistent with the single cycle point which was calculated before commencing the parametric study. If this point is not consistent with your parametric study - because you are using a different iteration setup during the parametric study, for example - then you should hide it.

Move the parameter values around with clicks on 🔄 (Arrange). Try this to find the nicest graph: each click will reposition the numbers. If the automatic placement of a parameter description is not satisfying then click the text, hold the mouse button down and move it to a better place.

If a text box with explanations for symbols shows up in the graphic you can move it to a suitable place: Click the box, hold the mouse button down and move the box to a new place.

You can also add some text to the graphic, click 💬 (Add Text) for that. A movable transparent window opens in which you can adjust the size, orientation, style and color of the additional text. After closing the transparent window you can move the added text with your mouse if necessary.

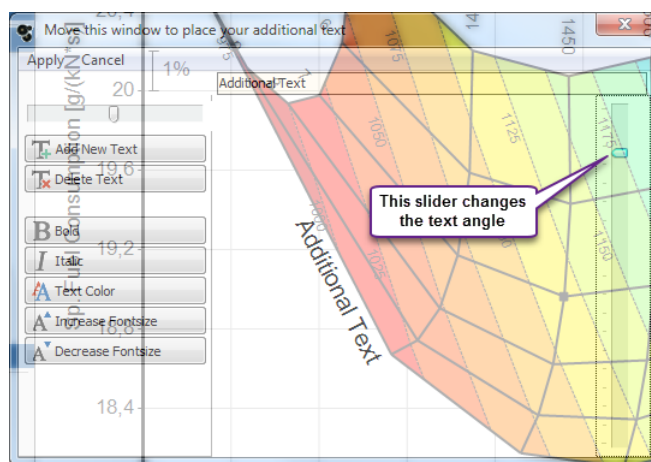

You can produce graphs with or without grid lines. From a figure with fine grid lines you can read numbers without the help of a ruler. Reading numbers from a plot without these grid lines is a cumbersome task because the spacing between grid lines on paper will not be even centimeters or inches.

With clicking the  (Splines) you switch between linear connections of the calculated points and the use of splines. With linear connections you get polygons which might look ugly. Note that the positioning of the contour lines and the boundaries of the color regions is based on a linear interpolation between the calculated points.

Further options in the graphical output window are export data to [Excel](#) and the [Picture Catalog](#).

8.6.2 Several y-Axes

If your parametric study employs only one parameter then you will get the choice for using up to four y-axes in one graphic. Which line belongs to which y-axis can be distinguished with the symbols that are the same on the line and the axis as highlighted with the arrows in the figure below.

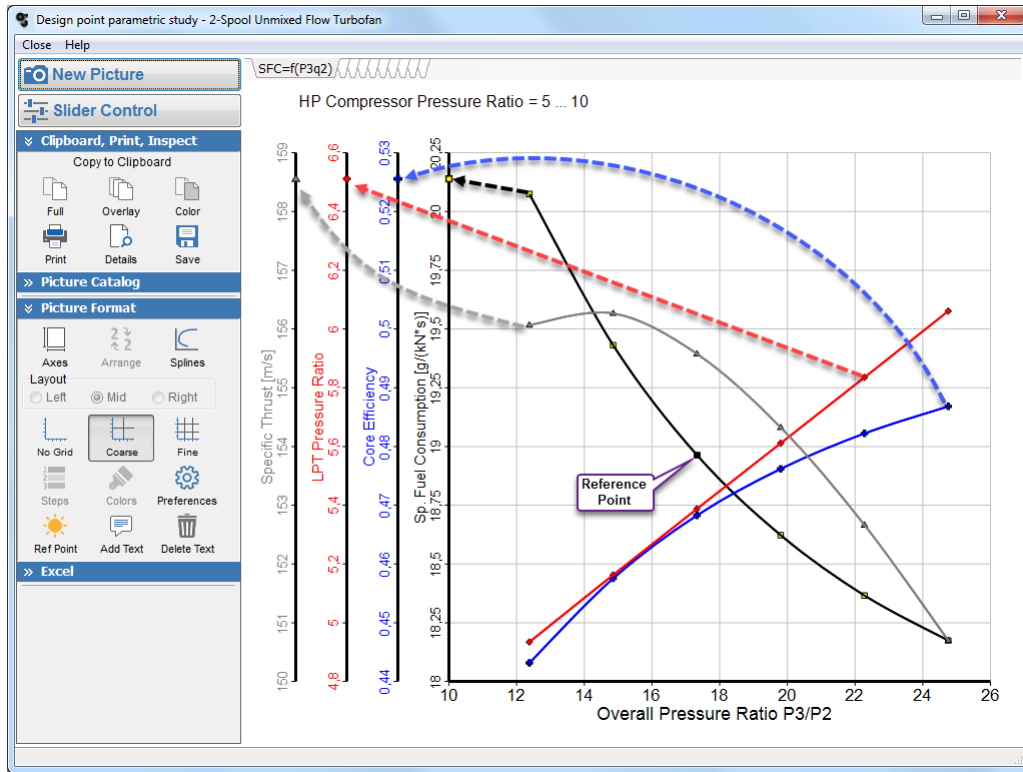

Most of the options in this graph are the same as for a graph with only **one y-axis**. When changing the scales of the axes the following window opens.

Here you can enter new numbers for the axes. Click the button with the hand pointing upwards if you want for y-axes 2 to 4 the same scale as for the first y-axis. Note that the program will accept your input only if your wish implies round numbers.



8.6.3 Copy to Clipboard

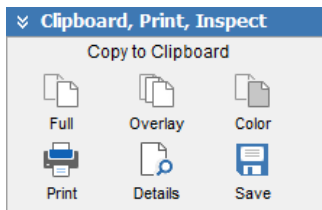

Most of the graphics can be exported to the Windows clipboard and from there pasted into other applications like a word processor or a presentation program. Clicking the *Copy to Clipboard* button copies the complete picture, including added text, to the windows clipboard. *Copy as Overlay* is a copy without the axes, they are replaced by little markers. *Overlay in Special Color* opens a color selection box before actually creating the copy. One pasted into these applications, the graphics can be ungrouped and then edited like vector files.

The graphics are exported as a Windows metafile which is a collection of Windows GDI output functions. Because metafiles store actual GDI output calls, they usually are much smaller than a bitmap; they can also be scaled to almost any size without losing the details. GasTurb 13 stores the data in the enhanced metafile format. The size of the copy can be modified in the *Options* window which can be opened with a click on (*Options*) in the *Extras* button group of the *Design Point Input* window.

8.6.4 Contour Lines

Contour lines are lines in a carpet plot (a graph with 2 parameters) along which a property is constant. Contour lines are, for example, the lines of constant efficiency in a compressor map.

If you have a graphic with contour lines and are not happy with the automatic selection of the colors or the contour line values then click (*Steps*) to change that. Enter new values for the lowest and highest contour value and change the step size and then *Apply* your choice. With the two color buttons you can affect the sequence of colors.

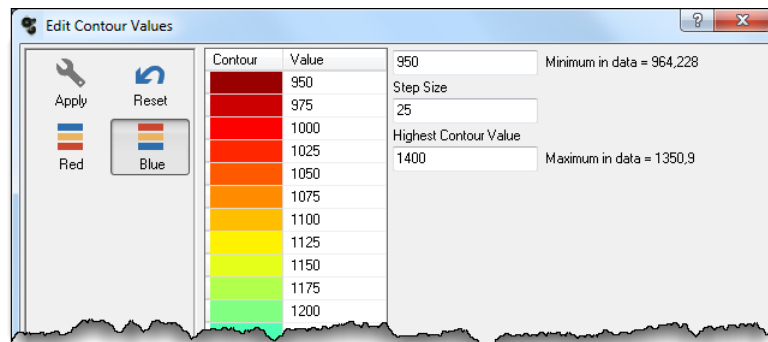

8.6.5 Picture Catalog

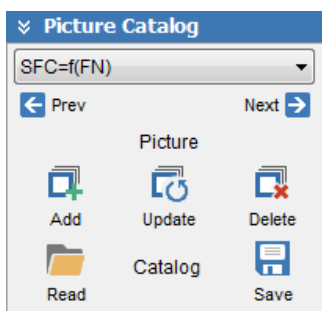

Pictures can be stored in a *Picture Catalog*. From such a catalog you can select pictures much quicker than with the normal procedure. A picture catalog is especially helpful if you want to match a model to given data.

Since the scales of the axes are stored in the picture catalog it may happen that no data are visible because all of the results are outside the predefined ranges. In such a case click (*Axis*) and select appropriate scales.

8.7 Options

When you choose *Options...* from the menu in the program opening window or click the  (*Options*) button in the *Extras* button group of the *Off-Design Input* window then the options dialog opens:

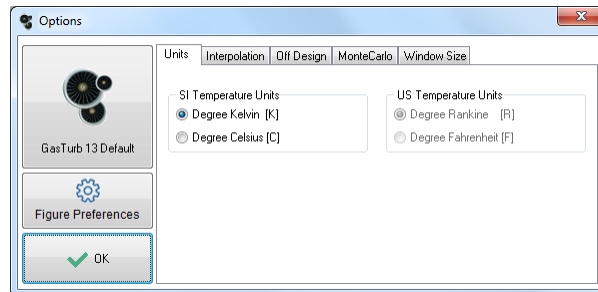

Here you can choose the temperature units and more. On the second page you can choose the interpolation mode for the temperature rise tables. These tables are employed when evaluating the temperature rise due to combustion of fuel. This option is offered for backwards compatibility reasons; in some older versions of GasTurb the tables were interpolated linear.

The off-design page offers several alternatives. The first three options are self explanatory, the fourth needs some explanation. If you encounter [convergence problems](#) then these might be caused by badly estimated values for the iteration variables.

Assume the case that you have a converged solution for Take Off power and want to calculate next Idle power. The estimated iteration variable values for the Idle case are those from the Take Off case. For Idle power this is a poor guess which might cause that the Newton Raphson algorithm fail to converge. If that happens a restart of the iteration might help.

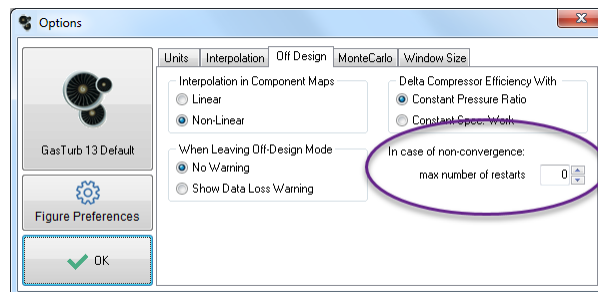

The first step of the restart goes for an operating point half way between Take Off and Idle power. For this mid point the Take Off variable values are better suited as a guess than for Idle and the chance for achieving convergence is significantly enhanced. After the mid point has converged, improved estimates for Idle power are available. The next attempt to find the Idle solution has a good chance to converge.

There is the temptation to set always the maximum number of restarts to three or five. However, there is a drawback of this decision. Think of an operating line calculation from high power downwards. At the low power end of the operating line it might happen that no solution exists because the requested operating point is far outside of one or more component maps. When no solution exists, a high number of restarts will not create a solution but only consume a considerable amount of calculation time. Therefore the default number of restarts is zero.

The *Monte Carlo* page is again self explanatory. The *Window Size* page offers the following:

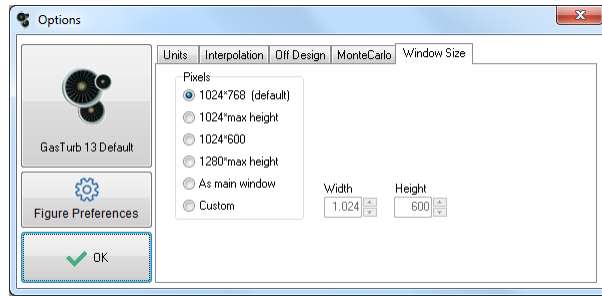

Here the Copy to Clipboard Size [%] needs explanation. With 100% Clipboard size any graphic pasted to Power Point will make use of the full slide area. If you prefer a smaller graphic on your slides, then use 75%, for example. Of course you can re-size any graphic you have pasted into Power Point.

Mathematics





9 Mathematics

9.1 Iteration Algorithms

9.1.1 General Iteration Technique

The calculation of each off-design point requires iteration. Several input variables for the thermodynamic cycle must be estimated. The result of each pass through the cycle calculations is a set of *Iteration Errors* which are inconsistencies in the aero-thermodynamics introduced through the use of imperfect estimates for the variables. The number of errors equals the number of variables.

The algorithm used to manipulate the variables in such a way that in the end all errors will be insignificant is a *Newton-Raphson* iteration. With two variables V_j and two errors E_i this algorithm works as follows:

First the variable V_1 is changed by the small amount of ∂V_1 . Both errors E_1 and E_2 will change, and we will get the influence coefficients $\partial E_1/\partial V_1$ and $\partial E_2/\partial V_1$. Then V_1 is reset to its original value and the second variable V_2 is changed by the amount ∂V_2 . Again both errors will change and we will get $\partial E_1/\partial V_2$ and $\partial E_2/\partial V_2$.

Let us assume for the moment that the influence coefficients $\partial E_i/\partial V_j$ are constant. Then we can immediately calculate how the variables V_j need to be changed to reduce the errors E_i to zero:

$$\begin{aligned}\frac{\partial E_1}{\partial V_1} \Delta V_1 + \frac{\partial E_1}{\partial V_2} \Delta V_2 &= -E_1 \\ \frac{\partial E_2}{\partial V_1} \Delta V_1 + \frac{\partial E_2}{\partial V_2} \Delta V_2 &= -E_2\end{aligned}$$

In practical applications to gas turbine performance problems, the influence coefficients are not constant and these changes of the V_j will not directly lead to $E_i=0$ after this single correction. Have a look at the numerical example in the next section for getting better acquainted with the *Newton-Raphson* algorithm.

The algorithm can be applied to any number of variables. The matrix of influence coefficients is called the *Jacobi matrix*. The system of linear equations is solved by means of the Gauss algorithm.

GasTurb 13 shows the iteration variables and their estimated values on the [Iteration page](#) in the *Off-Design Input* window. If the estimated values are too far away from the solution, the program may have convergence problems. In this case you must make several intermediate steps from a converged solution toward the desired off-design operating condition.

The single off-design point output contains the number of iteration loops used. If the iteration has not converged, then the sum of the square of the iteration errors $\Sigma \text{Error}^2 = \Sigma E_i^2$ is also shown. The last digit of ΣError^2 will be zero or one after full convergence. If the program fails to achieve full convergence ($\Sigma \text{Error}^2 > 10^{-8}$), it will show the point with the smallest ΣError^2 encountered during the iteration process.

With the help of the [convergence monitor](#) you can observe how the iteration proceeds and possibly see why an iteration fails to converge.

For transient simulations the implicit *Euler integration* method is used which means that for each time step a *Newton-Raphson* iteration is performed. You can select the integration time step as required.

9.1.2 Numerical Example

A numerical example involving two variables illustrates the *Newton-Raphson* iteration technique. Let's look at the following linear relationships:

$$E_1 = 5 \cdot V_1 + 3 \cdot V_2 + 4$$

$$E_2 = -3 \cdot V_1 + 7 \cdot V_2 + 24$$

We are looking for the set of variables that reduces both errors E_1 and E_2 to zero. Let us guess and set $V_1 = 3$ and $V_2 = 7$. By checking the equation we find that $E_1 = 40$ and $E_2 = 64$. Now the *Newton-Raphson* iteration is started. First the partial derivatives needed to create the *Jacobi Matrix* are calculated:

$$\frac{\partial E_1}{\partial V_1} = 5 \quad \frac{\partial E_1}{\partial V_2} = 3$$

$$\frac{\partial E_2}{\partial V_1} = -3 \quad \frac{\partial E_2}{\partial V_2} = 7$$

The changes needed to reduce both E_1 and E_2 to zero can then be calculated as follows:

$$5 \cdot \Delta V_1 + 3 \cdot \Delta V_2 = -40$$

$$-3 \cdot \Delta V_1 + 7 \cdot \Delta V_2 = -64$$

The solution to this system of linear equations is $\Delta V_1 = -2$ and $\Delta V_2 = -10$. The new values for the iteration variables are then $V_1 = 3 - 2 = 1$ and $V_2 = 7 - 10 = -3$. If we insert these values into the equations for E_1 and E_2 we will see that both E_1 and E_2 are zero as desired.

In the previous example the relation between the variables and the errors was linear. We now try the following quadratic functions as an exercise:

$$E_1 = V_1^2 - 5 \cdot V_2^2 - 307 \cdot V_1 - 2515 \cdot V_2 - 5400$$

$$E_2 = -3 \cdot V_1^2 + V_2^2 + 921 \cdot V_1 + 503 \cdot V_2 - 4800$$

We start with $V_1 = 11$ and $V_2 = 3$. After creating the *Jacobi Matrix* and solving the linear equation the improved estimates are $V_1 = 6.944$ and $V_2 = -2.929$. The exact solution is $V_1 = 7$ and $V_2 = -3$.

9.1.3 Convergence Problems

There are five typical reasons for convergence problems:

1. The estimated values for the iteration variables are very different to those of the solution
2. The lower or upper variable limits of a user defined iteration are too restrictive and exclude the solution from the permissible variable range.
3. In off-design the solution is far outside one or several component maps.
4. One or more variables have no influence on any of the iteration errors.
5. No solution exists.

For examining convergence problems you should start with a converged point and go in small steps into the problem area. Thus you get for each point estimated values of the iteration variables that are near to the solution for the next step. You can influence the convergence behavior in a similar way by changing the [number of restarts](#) in the *Options* window.

If an off-design iteration does not converge then check for the last converged solution to see if the operating points are all within the component maps. Note that GasTurb 13 tolerates only a limited



amount of map extrapolation to avoid that unreasonable results are shown as valid solution. Check also the lower and upper limits for user defined iteration variables.

If the iteration does not converge while all the operating points in the turbomachines are within their maps then it is very probable that no solution exists provided that all iteration variables affect at least one of the iteration errors.

A reason for convergence problems at low power ratings may be caused by specifying T_4 instead of relative spool speed. If you plot T_4 over spool speed then there might be a minimum of T_4 and at very low power T_4 increases with decreasing speed. If you specify T_4 lower than the minimum T_4 then the iteration can and will not converge.

You can deliberately create a convergence problem by steadily increasing the power offtake while T_4 is given: If you exceed a certain level of power offtake, then no steady state operation is possible and the iteration will fail to converge. To create an example take the TURBOJET configuration, load the file Demo_jet.CYC and go to the *Off-Design Input* window. Click (*Special*) in the *Maps and Connections* button group and set the turbine reference point to Beta,ds=0.5 and N/sqrt(T),ds=1.1. Close the *Special Component Maps* window and switch to *ZT4 given* with specified $T_4=1450$. Set power offtake to 1150kW and run the case, you will get a converged solution and the operating points in both maps are in healthy regions. Then increase power offtake a little bit to 1180 kW - no converged solution exists for this high power offtake. With the specified turbine inlet temperature of 1450 K there is not enough energy available for steady state operation with 1180kW power offtake.

9.1.4 Convergence Monitor

If an iteration does not converge then this can have many reasons. The convergence monitor helps understanding what happens during the iteration and shows how the iteration proceeds step-by-step. Click the (*Convergence Monitor*) button in the Extras button group to open the monitor window and then start the calculation of a single off-design point by clicking **Off Design Point**.

Convergence Monitor					
File View Pause Help					
Variables Jacobi Settings Output					
Loop No.14 converged		Sum of errors squared = 3,98561E-10			
No.	Variable	Value	Relative Value	Error	Value
1	Betavalue in HPC Map	0,498425		HPT Flow	-1,82356E-07
2	Burner Temperature ZT4	1615,15		HPT Work	-1,70567E-08
3	Betavalue in LPC Map	0,488835		Core Nozzle	1,06329E-05
4	LPC Spool Speed ZXNL	0,995382		LPT Flow	-2,62203E-07
5	Estimated Bypass Ratio	8,16066		Byp Nozzle P/P	2,13369E-07
6	Betavalue in IPC Map	0,430121		IPC Flow	-8,45534E-07
7	Betavalue in HPT Map	0,499784		HPC Flow	5,06801E-07
8	Betavalue in LPT Map	0,49368		LPT P/P	1,68637E-05
9	delta T Recirculating Bleed	-4,14272E-06		T2-T1 Recirc	-3,78956E-15

On the *Variables* page you see the names of the iteration variables in the second column and in the third column the actual value of this variable. The fourth column shows the same value graphically within the range from minimum to maximum. The fifth column contains an explanation of the *Iteration Error* and in the last column the numeric value of the error is displayed.

The minimum respectively maximum values of the predefined off-design variables are set automatically and cannot be modified by the user. The user-defined additions to the off-design iteration system and all cycle design iterations have variable limits that are input quantities in the *Iteration* definition window.

When a minimum or maximum limit is set too stringent then this prevents the iteration to converge. In such a case the blue line in the *Relative Value* column will move to the right respectively left column border. Resetting the relevant limit can resolve the problem.

On the second page of the convergence monitor the normalized *Jacobi Matrix* is shown. If in a row j all the values are zero, then the variable V_j has no influence on the value of any of the errors E_i . Similarly, if in a column j there are only zeros, then the Iteration Error E_j is not affected by any of the variables. In both cases the mathematical solution is undefined and the iteration will not converge.

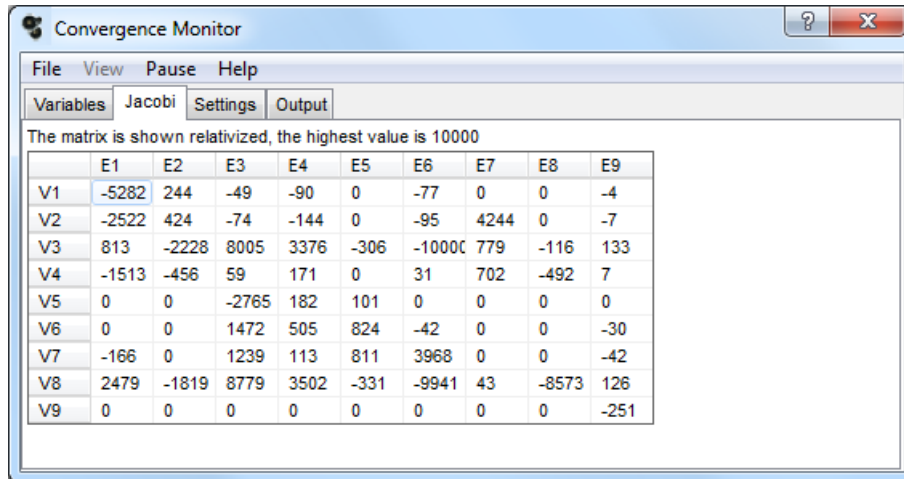

	E1	E2	E3	E4	E5	E6	E7	E8	E9
V1	-5282	244	-49	-90	0	-77	0	0	-4
V2	-2522	424	-74	-144	0	-95	4244	0	-7
V3	813	-2228	8005	3376	-306	-10000	779	-116	133
V4	-1513	-456	59	171	0	31	702	-492	7
V5	0	0	-2765	182	101	0	0	0	0
V6	0	0	1472	505	824	-42	0	0	-30
V7	-166	0	1239	113	811	3968	0	0	-42
V8	2479	-1819	8779	3502	-331	-9941	43	-8573	126
V9	0	0	0	0	0	0	0	0	-251

On the *Settings* page you can modify some parameters that influence the iteration algorithm, however, this is seldom required.

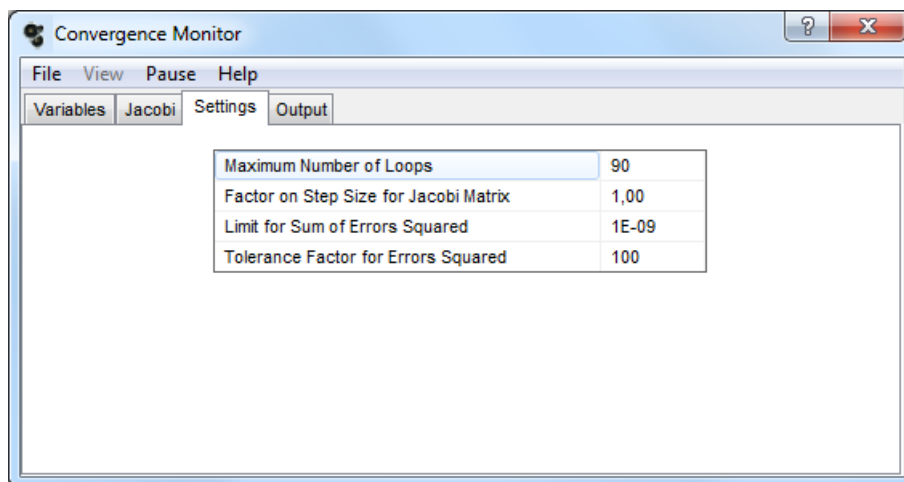

Maximum Number of Loops	90
Factor on Step Size for Jacobi Matrix	1,00
Limit for Sum of Errors Squared	1E-09
Tolerance Factor for Errors Squared	100

Maximum Number of Loops

After the maximum number of loops through the engine model the algorithm will stop and check if the sum of errors squared is lower than the limit multiplied by the *Tolerance Factor for Errors Squared*. If this condition is met then the solution will be accepted, otherwise the point is declared as not converged.

Factor on Step Size for Jacobi Matrix

The Jacobi Matrix is generated using finite differences. The size of the differences (steps) influences the quality of the matrix: too large steps introduce errors due to the non-linearities of the problem and too small steps introduce numerical error. The step size which is automatically selected by the program changes both its magnitude and its sign with each new *Jacobi Matrix*. You can change the size of the steps by setting the *Factor on Step Size* to a value unequal to 1.0.

Limit for Sum of Errors Squared

As soon as the sum of errors squared is below the specified limit the iteration is declared as converged.



Tolerance Factor for Errors Squared

See explanations for the topic *Maximum Number of Loops*.

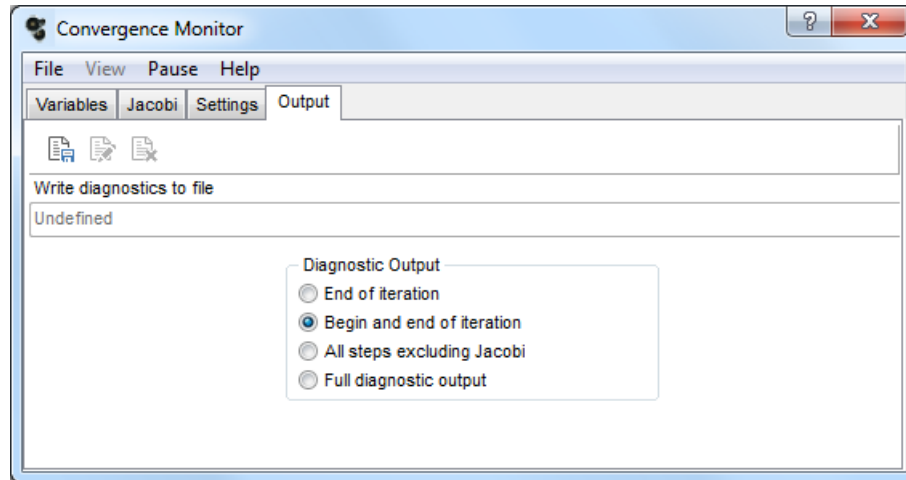

Finally, on the *Output* page you can make your choice about writing iteration diagnostics to a file for detailed examination.

9.1.5 Iteration Setup Examples

9.1.5.1 Single Spool Turbojet

Let us go through an off-design calculation with a given rotational speed. We will find the variables and the iteration errors mentioned in the previous section.

The calculation starts with the inlet. This provides the compressor inlet conditions. The compressor map has to be read next. Although we know the aerodynamic speed $N/\sqrt{\Theta_2}$, this is not sufficient to place the operating point in the map. An estimate for the auxiliary coordinate β_c is required. β_c is our *first variable*.

From the compressor map we can read the mass flow, the pressure ratio and the efficiency and then calculate the burner inlet conditions. The amount of fuel required for running the engine at the specified rotational speed is still unknown. An estimate for the burner exit temperature T_4 will yield the fuel-air-ratio. T_4 is the *second variable*.

The combustor exit mass flow W_4 is derived from the compressor exit flow W_3 , the internal air system (cooling air, bleed) and the fuel flow W_F . The pressure loss in the burner depends on the corrected burner inlet flow only. It's no problem to find the total pressure at the burner exit P_4 . We can directly calculate the corrected flow $W_4\sqrt{\Theta_4}/\delta_4$ at the inlet to the turbine.

Selecting the turbine operating point is similar to selecting that of the compressor: we know the corrected speed $N/\sqrt{\Theta_4}$, but not the value of the auxiliary map coordinate for reading the turbine map. β_T is the *third variable* we have to estimate.

Reading the turbine map provides us with the corrected flow $(W_4\sqrt{\Theta_4}/\delta_4)_{map}$ and the efficiency. Here the corrected flow is derived from a second source. The difference between both corrected flows constitutes the *first error* of our iteration. We will ignore this error for the moment and go on. The turbine exit conditions and the shaft power produced are calculated using the values read from the map. The difference between the power required driving the compressor and the power produced by the turbine (it is obvious that they must be equal to ensure steady state operation) is the *second error* of the iteration.

The pressure loss $(P_5 - P_6)/P_5$ in the turbine exit duct depends only on the corrected flow. When reheat is not switched on then P_6 equals the nozzle total pressure P_8 . Furthermore W_8 equals W_6 and T_8 equals T_6 . Thus the nozzle inlet conditions are fully fixed.

A certain total pressure $P_{8,req}$ is required to force the flow W_8 with the total temperature T_8 through the given area A_8 , while the back pressure is equal to P_{amb} . As long as the iteration has not yet converged there will be a difference between P_8 and $P_{8,req}$. This constitutes the *third error* of the iteration.

We have found three variables and three errors. The *Newton-Raphson* iteration algorithm modifies the variables in such a way that all the *Iteration Errors* equal zero.

The above explanation applies when the compressor rotational speed is specified. Alternatively the burner exit temperature T_4 can be specified. In this case the first variable will be the spool speed instead of T_4 , the calculation procedure and the iteration errors will remain the same.

When **limiters** are active then an additional Iteration Error is generated, which is the deviation from one of the specified limiting values. We now need an additional variable, we use both the compressor rotational speed and the burner exit temperature T_4 as estimated values. The program calculates the deviations for all limiters. The limiter errors are formulated in such a way that any value higher than the limiter setting results in a positive number. The selection of the biggest error out of all limiter errors ensures that no value will exceed its limit after convergence. The biggest error - which is nearly zero - defines the active limiter.

When reheat is selected the calculation described above will be done first - reheat fuel will not be taken into account until the iteration converges. The program uses an equivalent dry nozzle area during this part of the calculation. After convergence the reheat system (afterburner) is switched on. The calculation restarts in station 6, and produces new nozzle inlet conditions. These new conditions require a certain area A_8 in order that the flow can pass through the nozzle. If you wish to study the effect of different nozzle area settings on the reheated performance, you need to modify the equivalent dry nozzle area by entering a value of, say, 5% for Delta Nozzle Area.

If you want to specify thrust for a reheated case then an ambiguity arises: Thrust is affected both by the rating of the dry engine and the reheat exit temperature. The limiters affect the operation of the turbomachines only and therefore employing thrust as a limiter will not change the reheat exit temperature. With reheat switched on you should work with a **user defined addition to the iteration** with ZT7 as iteration variable and FN as iteration target. In parallel you may have limiters switched on which define the operating point of the turbomachines.

9.1.5.2 Two Spool Turboshaft, Turboprop

The setup of the off-design iteration for the two-spool turboshaft resembles that of the **turbojet**. Up to the high-pressure turbine exit the procedure is the same. The *first variable* is the auxiliary coordinate β_c which is used to read the compressor map. The *second variable* is either the rotational speed N_H of the compressor or the burner exit temperature T_4 . The *third variable* is the auxiliary coordinate β_{HPT} needed to read the map of the high-pressure turbine.

The burner exit corrected flow will not be equal to the HPT corrected flow as long as the iteration has not yet converged. The difference between both corrected flows constitutes the *first error* of our iteration. The high-pressure turbine (HPT) exit conditions and the shaft power it produces are calculated using the values read from the map. The difference between the power required for driving the compressor and the power produced by the turbine (it is obvious that they must be equal to ensure steady state operation) is the *second error* of the iteration.

We ignore this error for the moment and go on. The HPT exit conditions are derived from the power required to drive the attached compressor and from HPT efficiency. It is no problem to find the turbine inter-duct pressure loss. We can directly calculate the low-pressure turbine inlet corrected flow.



For this type of engine, the low-pressure spool speed N_L is an input quantity. Searching the low-pressure turbine operating point is similar to searching that of the compressor: we know the corrected speed $N_L/\sqrt{\Theta_{45}}$ for reading the LPT map, but not the value of the auxiliary map coordinate. β_{LPT} is the *fourth variable* which we have to estimate.

Reading the turbine map provides us with the corrected flow $(W_{45}\sqrt{\Theta_{45}/\delta_{45}})_{map}$ as well as the LPT efficiency. Here the corrected flow is derived from a second source - the difference between both corrected flows constitutes the *third error* of the iteration. We will ignore this error for the moment and go on. The LP turbine exit conditions and the shaft power delivered are calculated by means of the values read from the map.

The pressure loss $(P_5-P_6)/P_5$ of the turbine exit duct depends only on the corrected flow. P_6 is equal to the total pressure at the exhaust, P_8 . Furthermore W_8 equals W_6 and T_8 equals T_6 . The exhaust nozzle inlet conditions are thus fully determined.

A certain total pressure $P_{8,req}$ is required to force the flow W_8 with the total temperature T_8 through the given area A_8 , while the back pressure is equal to P_{amb} . As long as the iteration has not yet converged there will be a difference between P_8 and $P_{8,req}$. This constitutes the *fourth error* of the iteration.

We have found four variables and four errors. The *Newton-Raphson* iteration algorithm modifies the variables in such a way that all errors equal zero.

When limiters are used, then an additional error will exist which is the deviation from one of the specified limiting values, therefore an additional variable is required. Without limiters either N_{HPC} or T_4 can serve as a variable, but with limiters both N_{HPC} and T_4 are variables.

The program calculates the deviations for all activated limiters. The limiter errors are formulated in such a way that a value higher than the limit results in a positive number. The selection of the biggest limiter error ensures that after convergence no limiter will be exceeded. The biggest error - which is nearly zero - defines the "active limiter".

9.1.5.3 Boosted Turboshaft, Turboprop

For this type of engine, the low-pressure spool speed N_L is an input quantity. The booster map auxiliary coordinate β_{IPC} must be estimated; it is the first variable of the iteration. The inlet conditions and the data read from the map yield W_2 , T_{24} and P_{24} .

After the compressor inter-duct, the mass flow is reduced by the handling bleed, and W_{25} equals $W_{24} - W_{HdIBld}$. Total temperature does not change, the duct pressure loss can be calculated easily. The corrected mass flow in station 25 is now known.

Next the HP compressor map is read using N_{HPC} (which is either specified or estimated) and β_{HPC} yielding another value for the corrected flow: $(W_{25}\sqrt{\Theta_{25}/\delta_{25}})_{map}$. The difference between those two flows constitutes the first error of the iteration.

We find two turbine mass flow errors, the HPT work error and the nozzle inlet pressure error, as in the case of the two-spool turboshaft. The iteration scheme consists of the variables and errors listed in the table below if N_{HPC} is a specified value. In the alternative procedure T_4 is specified, and N_{HPC} is a variable for the iteration instead of T_4 . When limiters are used, the other variable is also employed giving a total of six errors and six variables.

Variable	Error
β_{IPC}	HPC flow

Variable	Error
N_{HPC}	HPT flow
β_{HPC}	HPT work
β_{HPT}	LPT flow
β_{LPT}	$P_8 - P_{8,required}$

9.1.5.4 Unmixed Flow Turbofan

The iteration starts with estimated values for the *first* and *second variable* of the iteration, the rotational speed of the low- pressure spool N_L and for the auxiliary coordinate β_{LPC} . This allows us to read the fan (LPC) map. The inlet conditions and the data read from the map yield T_{21} , P_{21} , T_{13} and P_{13} . The total mass flow W_2 is also derived from the map. We need to split this mass flow between the core and the bypass streams and estimate the bypass ratio, which constitutes the *third variable* of the turbofan iteration.

Core stream calculations will be done next. The compressor inter-duct pressure loss depends only on $W_{21}\sqrt{\Theta_{21}/\delta_{21}}$. After subtracting the handling bleed flow W_{HDBld} , we can find the corrected flow $W_{25}\sqrt{\Theta_{25}/\delta_{25}}$ at the high pressure compressor (HPC) inlet.

Let us assume that the rotational speed of the high-pressure spool N_H is a given value. To read the HPC map we need an estimate for the auxiliary coordinate β_{HPC} , which constitutes our *fourth variable*.

The pressure ratio P_3/P_{25} , efficiency η_{HPC} and the corrected flow $(W_{25}\sqrt{\Theta_{25}/\delta_{25}})_{map}$ can be read from the map. The difference between this corrected flow and the one calculated before constitutes the *first error* of the turbofan iteration. We will ignore this error and calculate the burner inlet conditions by means of the values read from the HPC map. Burner exit temperature T_4 is an estimated value, the *fifth variable* of the iteration.

Searching the HP turbine operating point is similar to searching that of the compressor: we know the corrected speed $N_H/\sqrt{\Theta_4}$, but not the value of the auxiliary map coordinate for reading the high-pressure turbine map. β_{HPT} is the *sixth variable* we have to estimate.

The burner exit corrected flow will not be equal to the HPT corrected flow as long as the iteration has not yet converged. The difference between both corrected flows constitutes the *second error* of our iteration. The high-pressure turbine (HPT) exit conditions and the shaft power produced are calculated using the values read from the map. The difference between the power required driving the high-pressure compressor and the power produced by the HPT (it is obvious that they must be equal to ensure steady state operation) is the *third error* of the iteration.

We will ignore this error for the moment and go on. The HPT exit conditions are derived from the power required to drive the high pressure compressor and from HPT efficiency. It presents no problem to find the turbine inter-duct pressure loss. We can directly calculate the low-pressure turbine inlet corrected flow $W_{45}\sqrt{\Theta_{45}/\delta_{45}}$.

Searching the low pressure turbine operating point is equivalent to searching the HPT operating point: we know the corrected speed $N_H/\sqrt{\Theta_{45}}$, but not the value of the auxiliary map coordinate for reading the high-pressure turbine map. β_{LPT} is the *seventh variable* we have to estimate. Reading the turbine map provides us with the corrected flow $(W_{45}\sqrt{\Theta_{45}/\delta_{45}})_{map}$ and the LPT efficiency. Here the corrected flow is derived from a second source. The difference between these corrected flows constitutes the *fourth error* of the iteration.



As usual we will ignore this error for the moment and proceed. The turbine exit conditions and the shaft power delivered are calculated using the values read from the map. The difference between the power required to drive the low- pressure compressor (fan) and the power delivered by the LPT (it is obvious that they must be equal to ensure steady state operation!) yields the *fifth error* of the iteration.

The pressure loss $(P_5-P_6)/P_5$ of the turbine exit duct depends only on the corrected flow $W_5\sqrt{\Theta_5/\delta_5}$. P_6 is equal to the total pressure P_δ in the core nozzle. Furthermore, W_δ is equal to W_6 and T_δ is equal to T_6 . The core nozzle inlet conditions are thus fully fixed.

A certain total pressure $P_{\delta,req}$ is required to force the flow W_δ with the total temperature T_δ through the given area A_δ , while the back pressure is equal to P_{arb} . As long as the iteration has not yet converged there will be a difference between P_δ and $P_{\delta,req}$. This constitutes the *sixth error* of the iteration.

We now go on with the bypass stream. Its pressure loss depends only on the bypass inlet corrected flow. P_{18} , T_{18} and W_{18} define secondary nozzle inlet conditions. Analogously to the core nozzle procedure we can calculate the pressure $P_{18,req}$ which is required to force the flow through the given area A_{18} . P_{18} will not be equal to $P_{18,req}$ during the iteration. This constitutes the *seventh error*.

We have found seven variables and seven errors. The *Newton-Raphson* iteration algorithm manipulates the variables in such a way that in the end all errors equal zero.

9.1.5.5 Mixed Flow Turbofan

The iteration for a mixed turbofan is very similar to that for an unmixed turbofan, as described in the previous section. It leads to the same variables, and all the errors are the same except one. We obviously have to replace the error derived from flow continuity in the secondary nozzle.

The *seventh error* for the mixed turbofan is the difference between the static pressures P_{s63} and P_{s163} in the mixing plane.

9.1.5.6 Geared Turbofan

The iteration for the geared turbofan is also very similar to that described for the unmixed turbofan. The difference is in the additional intermediate pressure compressor (IPC). Its rotational speed is easily derived from N_L , since it is connected to the fan mechanically. We must, however, make an estimate for the auxiliary coordinate β_{IPC} in addition to the seven variables of the unmixed turbofan.

There is also an additional error: The corrected flow $W_{21}\sqrt{\Theta_{21}/\delta_{21}}$ downstream of the low pressure compressor (fan) will not be the same as the value read from the IPC map $(W_{21}\sqrt{\Theta_{21}/\delta_{21}})_{map}$.

There will be eight variables and eight errors for the geared turbofan, if we have not switched on some limiters. With limiters there will be nine errors and nine variables. For the *Newton-Raphson* iteration this does not present a problem.

A transient calculation uses as iteration variables fuel flow, acceleration rates for the rotors, and the auxiliary coordinates in the component maps. In the table below all the variables and the corresponding errors employed during the simulation of transients are listed.

Variable	Error
dN/dt	IPC flow error

Variable	Error
dN_H/dt	HPC flow error
W_f	$W_f - W_{f,Control\ System}$
BPR	HPT flow error
β_{HPT}	HPT work error
β_{LPC}	LPT flow error
β_{IPC}	LPT work error
β_{HPC}	$P_8 - P_{8,required}$
β_{LPT}	$P_{18} - P_{18,required}$

9.1.5.7 Variable Cycle Engine

The variable cycle engine is a special case because the required iteration setup varies with the switch position of the VABI's (Variable Bypass Injectors). While all VABI's are open the variables and errors are

Variable	Error
N_L	HPT flow
β_{LPC}	HPT work
BPR ₂	$P_8 - P_{8,required}$
BPR ₁₅	LPT flow
β_{IPC}	Main mixer error (station 64)
N_H	Core driven fan stage flow
β_{HPC}	HPC flow
β_{HPT}	LPT work
β_{LPT}	Bypass mixer error (station 15)

Thus there are nine variables and nine errors while all VABI's are open. When either the first or the second VABI is closed then the two bypass ratios are the same and there is no bypass mixer error. The iteration employs in this case only eight variables and errors.



9.2 Monte Carlo Simulations

9.2.1 Overview

The *Monte Carlo* method has its name from the casino in Monte Carlo where many statistical experiments are made by the gamblers. The physical experiment with the ball in the gambling room is replaced in a Monte Carlo simulation by running a computer model with randomly distributed input data. The simulation yields output properties that are again randomly distributed. The distributions of the output properties can be analyzed for their mean values, standard deviations, confidence levels etc.

The Monte Carlo simulation method implemented in GasTurb 13 calculates many cycles in which some selected cycle input parameters are randomly distributed. Normal distributions with specified standard deviation or asymmetric distributions will be created for the selected input parameters. The results are presented graphically as bar charts together with points that indicate the shape of a corresponding Gaussian distribution.

9.2.2 Statistical Background

Probability Distribution and Confidence Level

Everybody knows the probability density plot for a so-called standard distribution which looks like a bell. The more general case is a non-symmetrical probability distribution with the density $p(x)$ as shown in the figure. The probability $P(x)$, that the performance level is less than x , is given by the colored area.

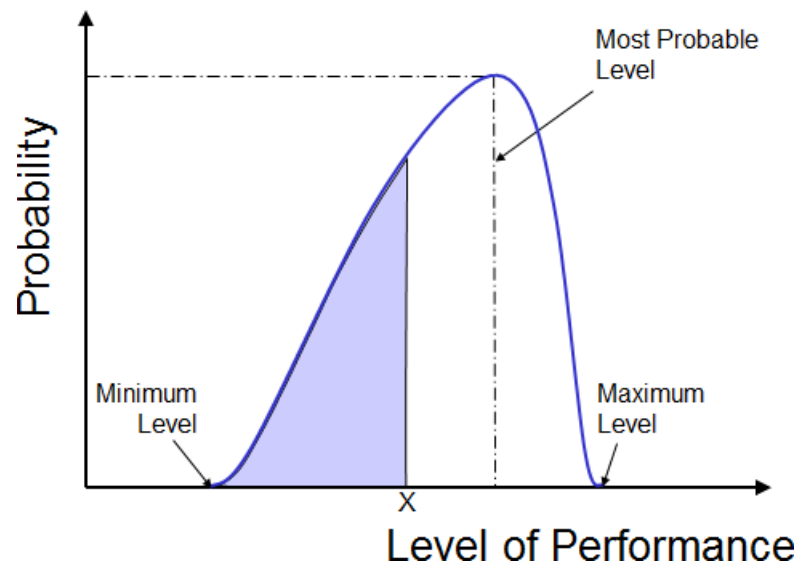

If the random event is the achievement of a component efficiency level η_0 , for example, then the probability of missing this efficiency level $P(\eta_0)$ is connected with the probability density $p(\eta)$ by

$$P(\eta_0) = \int_0^{\eta_0} p(\eta) \cdot d\eta$$

Instead of the probability often also the confidence level C is used in discussions. The confidence level is equal to $1 - P(x)$ and expresses the probability that a certain performance level is achieved. In the example of the figure above the confidence level of achieving the minimum performance would be 1 (respectively 100%) and the confidence level of achieving the maximum performance would be zero. Note that because the example distribution is not symmetrical the confidence level of achieving the most probable level is less than 50%.

About Root-Sum-Squared

If n random variables are independent from each other and each of these variables follows a Gaussian distribution with the mean value $V_{m,i}$ and the standard deviation σ_i then any random variable which is a linear combination of the n random variables will also follow a Gaussian distribution. The mean value ξ of this Gaussian distribution can be calculated as

$$\xi = \sum_{i=1}^n k_i \cdot V_{m,i}$$

For the standard deviation σ holds

$$\sigma = \sqrt{\sum k_i^2 \cdot \sigma_i^2}$$

The preconditions for the use of the *Root-Sum-Square* method are

- The random variables are independent from each other
- Each of them follows a Gaussian distribution
- Their effects on the quantity of interest can be linearly combined

When one or more of these conditions are not fulfilled then the *Root-Sum-Squared* method must not be applied.

Monte Carlo Method

The computer model employed with the Monte Carlo simulation yields the connections between input and output. The random variables may or may not be independent from each other as required for the application of the *Root-Sum-Squared* method. Moreover, the correlations between the variables involved need not to be linear. So the Monte Carlo method has much less restrictions for its use than the *Root-Sum-Squared* method and it can be applied to very complex problems.

9.2.3 Symmetrical Distributions

If you select a normal (Gauss) distribution for your Monte Carlo simulation then you enter the standard deviation s for selected properties. The program will generate normal distributed random numbers with the specified standard deviation. Values outside of the range of mean value +/- 2σ are not considered. With a normal distribution (Gaussian distribution) 68% of all data will be in the range of +/- σ and 95% in the range of +/- 2σ

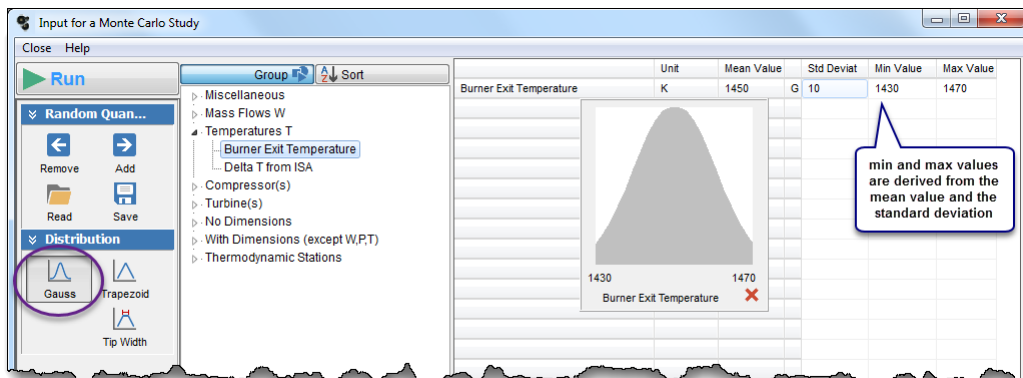

The random distributions for all input data are independent of each other in a cycle design Monte Carlo study. In an off-design study, however, there are a few properties that are **connected** with each other.



9.2.4 Asymmetric (Trapezoid) Distribution

If you select an asymmetric (trapezoid) distribution for your Monte Carlo simulation then you must enter the minimum and the maximum value for selected properties. The standard deviation input is in this case of no relevance. The minimum value must be lower than the nominal value and the maximum value must be higher than the nominal value. If the distances $X_{nom} - X_{min}$ and $X_{max} - X_{nom}$ are different then the distribution will be asymmetric as indicated by the graphic in the input window. The default value for the trapezoid tip width is 20% of the base width. You can change that value in the Options window.

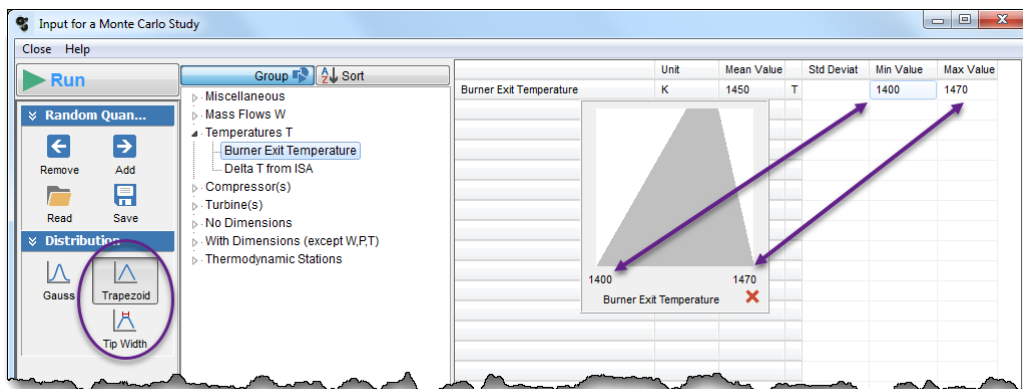
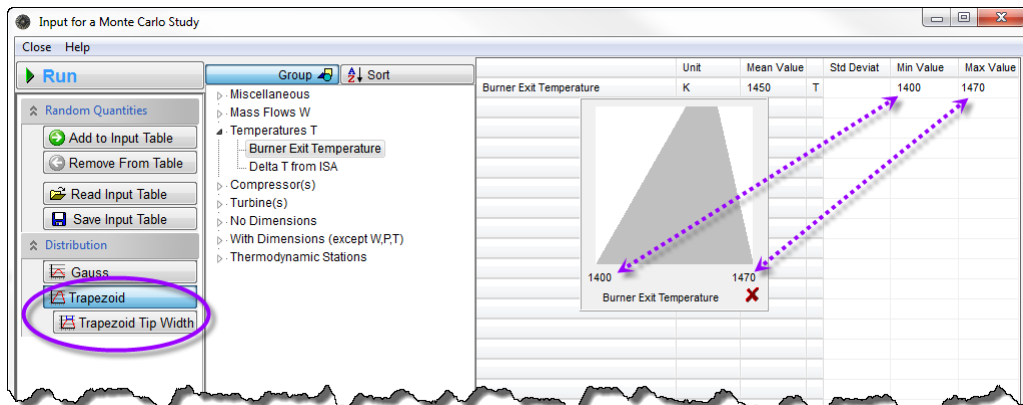

Switch between normal and trapezoid distributions by a click on the corresponding button. The distribution type selected is marked in the forth column of the table by **G** respectively **T**.

In a cycle design Monte Carlo study the random distributions for all input data are independent of each other. In an off-design study there are a few properties that are **connected** with each other.

9.3 Optimization Strategies

What is "optimization" in a mathematical sense? It requires a mathematical model of reality. A complex engine model, for example, provides many outputs such as thrust, fuel consumption, weight, noise, manufacturing cost etc., for any meaningful combination of input variables.

One quantity is selected as a *figure of merit*: The mathematical model is then driven to an extreme value of the figure of merit by the optimization algorithm. You can, for example, ask for the engine with the lowest weight.

The figure of merit alone does not fully describe the problem. Normally there are *Constraints* for both the variables and the results. For an engine of a subsonic transport aircraft the optimization task could be: Minimize specific fuel consumption (figure of merit = SFC) with the following *Variables*:

Variable	min		max
Bypass ratio	6	BPR	12
Outer fan pressure ratio	1.5	P_{13}/P_2	1.8
IPC pressure ratio	1.5	P_{24}/P_2	6
HPC pressure ratio	6	P_3/P_{25}	12
Burner exit temperature	1400K	T4	1800K

Additionally there might be *Constraints*, for example:

Constraint	min		max
HPC exit temperature		T_3	840K
HPT exit temperature		T_{45}	1250K
Thrust	30 kN	FN	
HPT pressure ratio		P_4/P_{45}	3.2

It is not obvious how the variables affect the constraints. In many cases the relation between optimization variables and the constraints is very complex. It is impossible to see instantly whether a specific set of variables fulfills the constraints. There are only a few rules for setting up a mathematical model. The figure of merit and the values for the constraints must depend on the optimization variables directly. If a certain combination of variables results in an invalid figure of merit, the model must reply with an error message. Then it must give the control back to the optimization algorithm again.

Let us be more general now: The mathematical model of the engine is a function which provides exactly one value for the figure of merit Z and several values C_j for the constraints, for a set of optimization variables V_i .

We are looking for an algorithm to find the optimum set of variables. This set must have the highest figure of merit possible without violating any constraint. A minimization task can, by the way, be easily converted into a maximization task by multiplying the figure of merit by -1.

GasTurb 13 offers two optimization algorithms: a gradient strategy and a random search algorithm.

9.3.1 Gradient Search

There is a good example for an optimization task: A mountaineer shall climb the highest peak in a certain region. He has no map and the weather is foggy. His only tool is an altimeter. What is he going to do? He will certainly check his surroundings first and then go in the direction of the steepest ascent. In the end he will come to the top of a mountain. This is a place where each step leads downwards.



The steepest ascent may, however, lead toward a border (which is either the lower or upper limit of a design variable) of the region. Then our mountaineer will walk along the border until he reaches the place where each step leads downwards or out of the allowed region.

Is that the end of the story? Not necessarily. There might be several summits within the region. Our mountaineer may have found the highest peak by chance, but he cannot be sure of that. He has to check other parts of the region. In mathematical terms there might be *local* optima besides the *global* optimum.

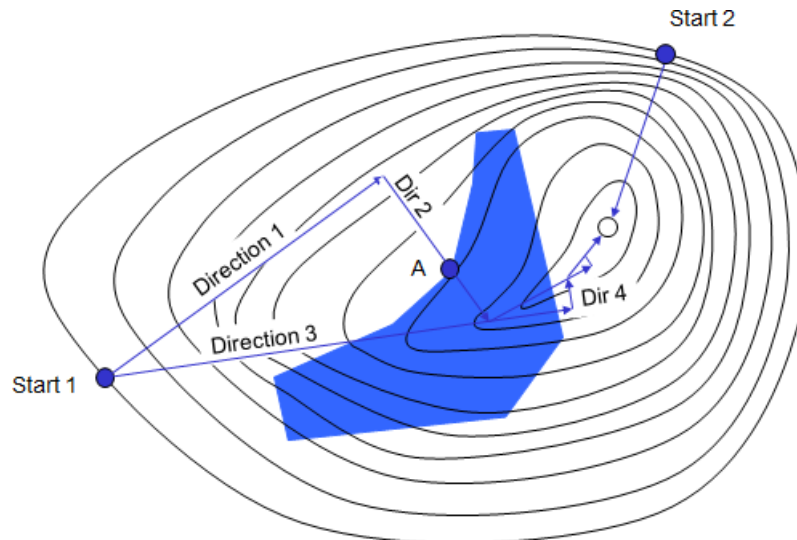

Up to now we have not spoken of constraints. They are like fences, a part of the region is off limits for our mountaineer. His task is made more difficult because on his way to the summit he may have to walk downwards for a while to avoid a forbidden region. The fences (the constraints) often exclude the summit (where each step leads downwards) as an acceptable solution. They create local optima that would not exist without fences. Constraints make the task of optimization difficult.

Let us turn to the mathematical algorithm now. The mountaineer who first makes test steps in several directions uses the *Gradient Strategy* as a search method. With the test steps he is looking for the partial derivatives $\partial Z/\partial V_i$. For each optimization variable he must do one test step before he can start his way in the "right" direction.

After the first step uphill the local gradients will be different. The test steps could now be repeated to find the new direction. Test steps take time, however, and it is therefore better to go on in the same direction as long as the altitude increases. Reaching a fence (violating a constraint) could be another reason for stopping the climb. Only then will new gradients be sought. The new direction will eventually take you along a fence.

The gradient search strategy which is implemented in the program is derived from Reference [18]. The principle is the following: we begin at the point marked *Start 1* in the figure with looking for the direction of the steepest gradient (Direction 1). Following this direction we walk to the highest point. Then we change direction by 90° (orthogonal). We can do this without evaluating the local gradient. Then once again we look for the highest point. To define the third direction we use the knowledge of the first two directions. We connect the point *Start 1* with the optimum point found along Direction 2. We follow this direction as long as altitude increases.

This procedure can be reapplied until the search steps or the changes in the figure of merit become very small. In the example above the optimum is found along search direction 7.

Up until now we have only dealt with optimization without constraints. In the figure there is a colored zone which suggests a forbidden region. If we use the strategy just described the search for the optimum will end at point **A** along Direction 2. We cannot find the global optimum if we begin at Start 1. If we begin at *Start 2*, however, we will reach the top of the hill very quickly.

Do not underestimate the danger of finding only a local optimum, particularly in cases involving several constraints. Repeat the optimization run from several starting points - the program offers the option *Restart* for this purpose. While doing a restart the program uses random numbers as the optimization variables and checks, which is the worst combination. However, the constraints must be fulfilled during the search for a new starting point. If you have found the same optimal solution from several starting points, you can be quite sure that you have found the global optimum.

9.3.2 Random Search

The adaptive random search strategy offered by GasTurb 13 is based on Reference [19]. In an adaptive random search - which has some similarity with a genetic algorithm - random numbers concentrated around the best solution found previously are used as the optimization variables. The algorithm is

$$V_i = V_i^* + \frac{R_i}{k_R} \cdot (2 \cdot \Theta - 1)^{k_v}$$

with

V_i	New value of optimization variable
V_i^*	Value of V_i producing the best figure of merit
R_i	Search region for variable V_i
k_R	Range reduction coefficient (positive integer)
k_v	Distribution coefficient (positive odd integer)
Θ	Random number between zero and one

To start an adaptive random search you should have a variable combination that fulfills all of the constraints. At the start of the search k_R is 10 and k_v is 1. In one search run the program tries 40 times the number of optimization variables random engine cycles. When all cycles have been calculated, then k_R will be duplicated and k_v will be increased by 2. The search region will get smaller. Another 40 times the number of optimization variables cycles will be calculated, and then k_R will be duplicated again and k_v will be further increased by 2. This procedure will be repeated until all cycles for $k_R=80$ have been tried. Cycles that do not fulfill the constraints will be ignored.

You can also switch over to the gradient search strategy each time the adaptive random search stops. Along with the *Restart* option this constitutes a very flexible tool for mathematical optimization.

It is obvious, that a very wide range for the variables at the begin of the optimization will yield only an inaccurate result. On the other side, a too small range for the variables can exclude the true optimum unintentionally.

The adaptive random search is combined with automatic restarts in the *Endless Random Search*. When an optimum solution has been found, then a random search moving away from the present optimum (a restart) is initiated automatically. This will create a new starting point for the optimization, and a new search will begin. Some of the searches may end in local optima, but some will find the global optimum in the search region.



If you have many optimization variables and several constraints in a complex optimization problem running on a slow computer, the endless random search is the best choice. You can do other jobs and leave the computer alone. Come back later, press the *Stop* button and you will see the best solution the computer has found during the last hour, for example. You should check this cycle thoroughly and look at the effects of small deviations from the optimum variable combination. Click the  (*Sensitivity*) button for that purpose.

How to ...





10 How to ...

10.1 ... Adjust the Cycle Design Point

The situation is that you have got data from an engine and you want to model that engine with GasTurb 13.

Select from the data you have got a point which will serve as *Cycle Reference Point*. Ideally this point is the design point of the engine, however, any high power operating point will do. The thus selected test data point is calculated with GasTurb 13 as a single point in *Cycle Design* mode.

For many of the engine configurations there is a *Test Analysis* option in cycle design mode. Whenever you have all the input data needed for this option then you should use it because that makes the adjustments of the GasTurb 13 input data very easy. With the *Test Analysis* option all temperatures and pressures on the compressor side are given and these define implicitly efficiency and pressure ratio for each of the compressors. On the turbine side the pressures are also input to the program. The only unknowns are the air system properties, the mechanical efficiencies and power offtake.

Adjust the air system properties in such a way that the calculated temperatures in the hot section of the engine line up with the given values. This can be done by trial and error combined with parametric studies and iterations. You can also employ optimization in which the air system properties are the optimization variables and the figure of merit is the sum of all $(T_{\text{calculated}} - T_{\text{given}})^2$ from the hot section of the engine. Use *composed values* for the calculation of the figure of merit.

If you are simulating an engine with a single nozzle then the exhaust temperature can be checked easily: Consider the engine as a black box which has two incoming energy streams: the intake air flow and the fuel flow. If no secondary air leaks from the black box and no power offtake exists then the energy of the exhaust gases (their total temperature) follows from the law of conservation of energy. If the exhaust temperature calculated by GasTurb 13 does not line up with the temperature given, then there must be some energy leak like an overboard bleed or power offtake.

When you have found the best match to the given data, check the box *Overwrite P/P, Eff and T4* input and run the calculation once more. This will modify your compressor pressure ratio, T_4 and efficiency input data in such a way, that you get with *Test Analysis* "off" the same result for the cycle design point as with *Test Analysis* "on" .

10.2 ... Adjust the Off-Design Model

At the *Cycle Reference Point* the match between the given data and the GasTurb 13 results is as good as you have adapted the data in cycle design mode. Other data points will deviate more or less from the simulated operating line. Prepare the known data in the same units as used in GasTurb for *reading them from file*. Then you can show them together with the GasTurb 13 results as *Comparative Data*.

The part load characteristics in terms of specific fuel consumption depends mainly on the component maps, especially those of the compressors. The compressor maps yield two correlations:

1. Corrected Mass Flow - Efficiency
2. Corrected Mass Flow - Corrected Speed

In the final model both correlations must be in line with those of the given data. It is recommended to deal with both correlations separately and to begin with the first correlation.

Flow - Efficiency Correlation

Plot and compare your compressor efficiency data in the first step at given compressor inlet corrected flow. If you do not have any component efficiency information then plot specific fuel consumption over shaft power respectively thrust. Do not use spool speeds in any of the plots while you are working on the first correlation.

For getting the efficiency characteristics and the specific fuel consumption right you must work on the correlation between the cycle design point and the component maps. With other words: you must find the place of the cycle design point in the component map(s) which yields the best part load characteristics. This is explained in the section [How to set the Design Points in the component maps](#).

Optimize the match between the given corrected flow and efficiency data and the GasTurb 13 results. The specific fuel consumption plotted over shaft power respectively thrust will be as good in line with the given data as the component loss assumptions are. Check also the hot end temperatures in plots over shaft power respectively thrust.

If shifting the cycle design point around in the map does not yield sufficient agreement between the data and the simulation then you can use a different map or even [modify the efficiency distribution in the map](#) within GasTurb 13.

Flow - Corrected Speed Correlation

When you are happy with all the comparative plots you have checked until now, then you can go for the second model adjustment step: getting the spool speeds right. This can be achieved with only small secondary effects on the already adjusted correlations by re-labeling the speed lines in the compressor maps.

Note that in the simulation of turbofan engines the booster operating line moves in the booster map if the speed lines of either the booster or the fan map are re-labeled. This operating line shift affects not only the booster part load efficiency, but also the correlations of booster exit temperature and pressure with global parameters like thrust, for example. After re-labeling the fan or booster speed lines the *Flow - Efficiency* Correlation should be checked again.

For the [adjustment of the Flow-Speed correlation](#) select the component from the *Compressors* button group in the *Operating Line* window.

After adjusting the *Flow - Speed* and *Flow - Efficiency* correlations you should store the modified map to file. Otherwise you will lose your results when closing the program. Besides storing the modified map itself you should also save your other data as an [Engine Model](#) file because only such a file will contain the reference to the new map.

10.3 ... Modify the Efficiency Distribution in a Compressor Map

The specific fuel consumption and the thermal efficiency at part load depend very much on the efficiency read from the compressor maps. While trying to match with the simulation a set of given data it might be necessary to modify the efficiency in the map; You can do that without leaving GasTurb 13.

In the *Operating Line* window click in the *Compare* button group the *Read Test Data* button and read the file with your known data. For comparing these data with the compressor map of your model you need data for efficiency, relative corrected speed and corrected mass flow. In case of a TURBOJET, for example, the short names for these quantities are e23is, XNRSTD and W2Rstd.

Click in the *Compressor Map(s)* button group the *Edit Compr Map* button. In the window that opens there is a list with the original [peak efficiency](#) numbers in the map. The numbers in the third column (*Delta Peak Efficiency*) can be edited individually or changed all together by moving the slider on the



right side of the figure. The graphic shows two lines: one which connects the peak efficiency points for all speed lines in the map and a second line with efficiency along the operating line.

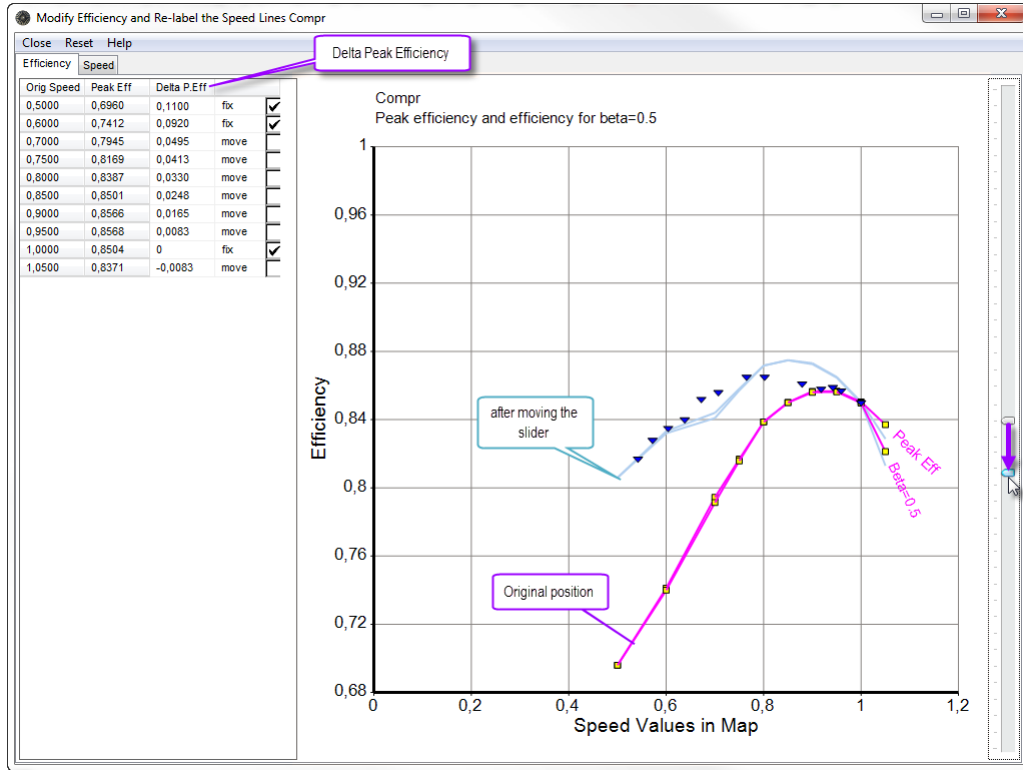

The task is now to modify the two lines in such a way that the test data agree with the map. You can manually edit the *Delta Peak Efficiency* values in the table or you can use the slider. While moving the slider, the numbers in the third column change, except those where the checkboxes are checked. Look at first only at the lowest speed value and move the lines with the slider to the optimal position. Then click the checkbox to fix the *Delta Peak Efficiency* value for that speed. Then proceed with the next speed, move the lines to the right place and fix the delta value.

Note that the data at the cycle design point will remain unchanged (because otherwise the correlation of the cycle design point with the map would be affected) and therefore you cannot modify efficiency at speed = 1.0, neither by editing the table nor by playing with the slider.

You cannot modify the efficiency and re-label the speed lines in one go. Adapt first the efficiency values and re-label the speed lines later. When closing the window then all the efficiency values in the map are factored by the peak efficiency ratio new old = f(Speed). Write the scaled map to file, otherwise you will lose the data when closing the Off Design Input window.

Finally you should check the modified map with the program **Smooth C** which offers many graphics that show if a map makes sense from a physics point of view.

10.4 ... Re-Label the Speed Lines in a Compressor Map

Re-labeling the speed lines in a compressor map is equivalent to using a different **variable geometry schedule**. For the adjustment of the *Flow - Speed* correlation of a map click in the *Compressor Map(s)* button group the relevant *Edit Compr Map* button. Make sure that you have loaded **comparative data** with the corrected flow and relative corrected speed - if available - before clicking the *Edit* button because that allows quickly matching the flow-speed correlation to given data. It is possible to re-label the speed lines also if you do not have comparative data, however, doing that is like flying in the dark without instruments.

There are three lines in this picture: one for the lowest corrected flow in the map (auxiliary coordinate $\beta=1$), a second for the middle of the map ($\beta=0.5$) and the third line represents the maximum corrected flow in the map ($\beta=0$). In the table on the left side you see the original speed values. You can re-label the speed lines by editing the numbers in the second column of the table or by using the slider below the figure. All changes will be shown immediately in the figure.

If a checkbox is checked, then the *Delta Speed* value of that line is fixed and no longer affected by the slider movement. It is convenient to fix one *Delta Speed* value after the other.

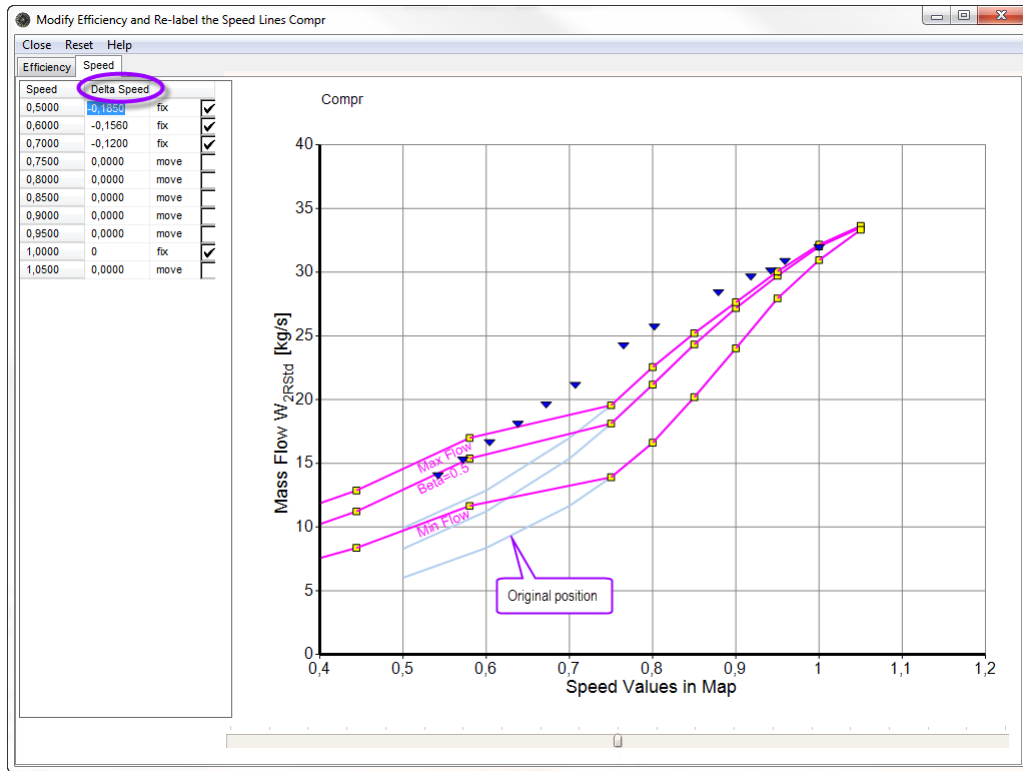

After adjusting the *flow-speed* correlation you should store the modified map to file. Otherwise you will lose your results when closing the program. Besides storing the modified map itself you should also save your other data as an [Engine Model](#) file because only such a file will contain the reference to the new map.

Usually, re-labeling the speed lines of a compressor map has nearly no effect on the operating line and the surge margin. With high bypass engines, however, if two separate maps are used for the core and the bypass stream, re-labeling the speed lines in the booster map can cause a significant shift of the booster operating line and affect the booster surge margin.

10.5 ... Set the Design Points in the Component Maps

Let us assume that a turbofan for a passenger transport aircraft application is to be simulated. Some data for the *Max Climb* rating at 35000ft, Mach 0.8 are known and some more data for the sea level *Take Off* condition.

Select the altitude case as a *Cycle Design (Cycle Reference) Point* and achieved in a first step a reasonable match of the GasTurb 13 results and the known data.

If you want to employ a scaled component map then you must select a scaling point in the not yet scaled map which will after scaling of the map be in line with the [cycle design point](#). The position of the scaling point in the map is described by the two coordinates N/\sqrt{T}_{ds} and β_{ds} . You can modify



these two coordinates in the *Special Component Maps* window which opens when you click the  (*Special*) button in the *Maps and Connections* button group.

The setting of the map scaling point (i.e. the cycle design point position in the map) influences the simulation results for off-design conditions (but not those of the cycle design point). Imagine you have set the cycle design point in the map at high corrected speed in a region where with increasing speed the efficiency decreases rapidly. In such a case the efficiency will change significantly with the corrected speed of the respective component during off-design simulations. However, if you set the cycle design point to a lower map speed in the region of with optimum efficiency then the efficiency will change only marginally with corrected speed.

You can perform a parametric study which shows the impact of moving the map scaling point on the simulation results at one selected off-design point with the following procedure:

- Do a cycle design point calculation and then go for the *Off-Design Input* window.
- Stay with the Standard Maps or load the maps of your choice.
- Do not modify any of the input data (except composed value definitions), go for a single point mission.
- Adjust the mission input data in such a way that you get the off-design condition you are interested in.
- Perform the mission calculation and check the results.
- Close both the *Mission List Output* window and the *Mission* window.
- Switch to *Parametric* study and run it.

In the parameter selection window you will find at the end of the parameter list in the *Map Reference Points* group the coordinates *Map Speed @ Design Pt* and *Map Beta @ Design Pt* of all the relevant maps. Select one or two of them as parameters and do the simulation: the graphical output will show the data from the off-design point which you have defined as the single point mission.

10.6 ... Model a Derivative Engine

The most expensive part of an engine is the gas generator or core, which consists of the high-pressure compressor HPC, the burner and the high-pressure turbine HPT. Engine companies therefore strive to use the same core for several applications. All engines with a common core constitute an *engine family*.

During cycle design calculations for a TWO SPOOL TURBOFAN, for example, the third option on the *Mass Flow Input* page allows you to use an HPC map. You specify with this option the map coordinates β_{HPC} and N/\sqrt{T}_{Map} of the HPC operating point. Reading the map at this point will yield mass flow, efficiency and pressure ratio of the HPC. The flow capacities of the turbines will be calculated in such a way, that this operating point is achieved.

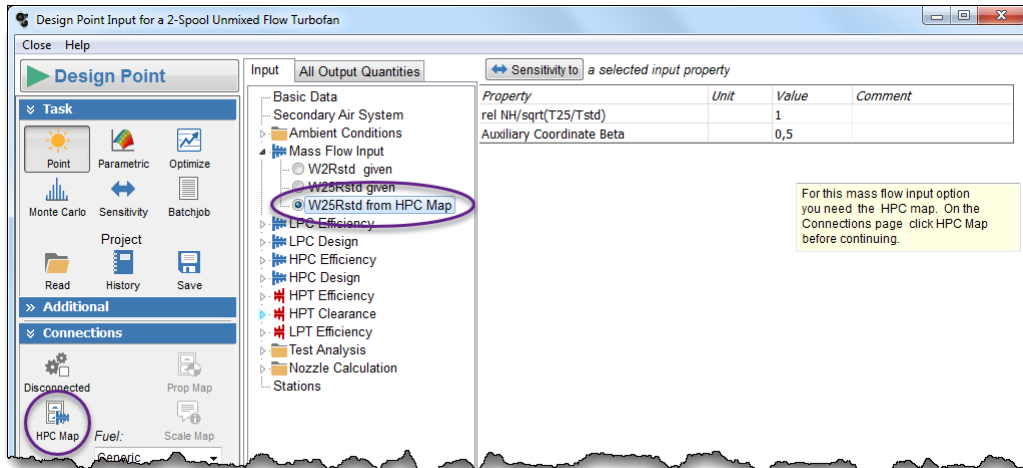

Before you can begin the cycle calculation with this option you must load an HPC map: click the  (HPC Map) button. After loading the map, the HPC Map window opens:

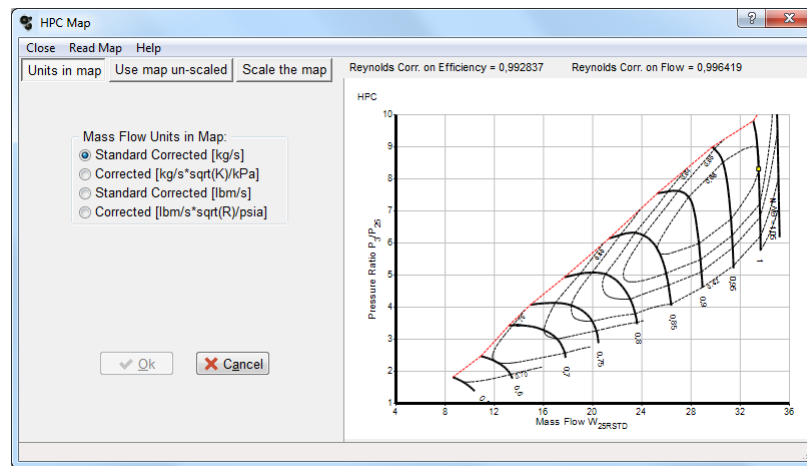

The map is shown on the right, and on the left you mark what the mass flow units in your map are.

Now you must decide if you want to use the map unscaled or scaled. In the unscaled map you can position the operating point by setting the auxiliary coordinate β and $rel\ NH/\sqrt{T25/Tstd}$. The corresponding values for mass flow, efficiency and pressure ratio will be shown in the box on the lower left side. Note that you can use a map unscaled only if you have read a map with [map reference speed information](#).

If you choose to scale the map, then you must input both the map coordinates and true values for mass flow, efficiency and pressure ratio. The resulting map scaling factors are shown on the lower left side:

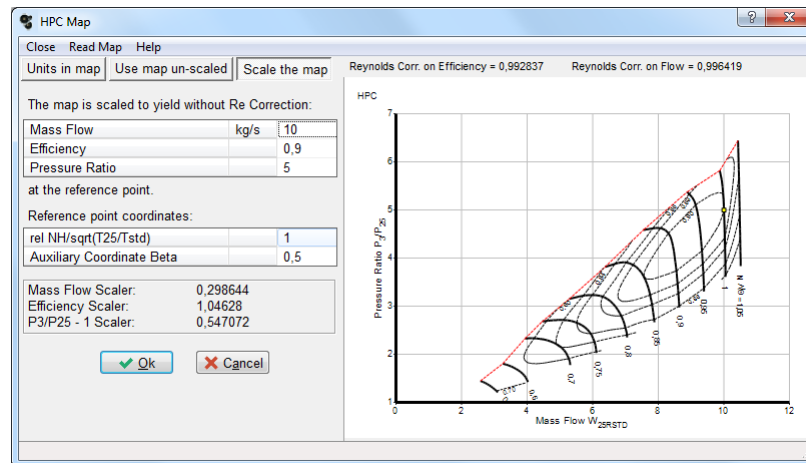

After the map has been scaled, the values for HPC mass flow, pressure ratio and efficiency will be read from the map as long as option 3 from the *Mass Flow Input* page remains selected.

10.7 ... Compare Data with GasTurb Results

If you have got data from another cycle program, from measurements or from literature you are certainly interested how these data compare to simulation results from GasTurb 13. Such a comparison is done in two steps:

First you calculate one of the given data points in Cycle Design mode to get your [cycle reference point](#). When you have found a reasonable match between your data and the GasTurb 13 results at this point then you can go for [adapting the model for off-design](#).

10.8 ... Calculate Off-Design Performance for Specified Thrust or Fuel Flow

If you want to run the engine to a specified thrust or fuel flow level then switch on the thrust or the fuel flow [limiter](#). For turboshaft engines specify the shaft power delivered instead of thrust.

You can switch on simultaneously several limiters or have [control schedules](#) active. If you do that then you can answer problems like:

Operate the engine in such a way that it delivers 30kN thrust provided that the high-pressure spool speed is not higher than 102%.

Note that during reheat (afterburner) operation of a jet engine an ambiguity arises: Thrust is affected both by the rating of the dry engine and the reheat exit temperature. The limiters affect the operation of the turbomachines only and therefore employing thrust as a limiter will adapt the mass flow, but not the reheat exit temperature.

With reheat switched on you should work with a [user defined addition to the iteration](#) with *ZT7* as iteration variable and net thrust *FN* as iteration target. In parallel you may have limiters switched on which define the operating point of the turbomachines.

10.9 ... Modify Reynolds Number Corrections

Reynolds number correction information is stored with the compressor and turbine maps. On the second line of a map file the Reynolds number correction factors of efficiency are given in the following form:

$$\text{reynolds: RNI} = x1 \quad f = y1 \quad \text{RNI} = x2 \quad f = y2$$

The laminar flow region was not considered prior to GasTurb 13.

The Reynolds correction data stored in a component map file is overridden by the data read from an Engine Model File or a Map scaling file.

The Reynolds correction for corrected flow is based on the number for efficiency correction. For example, when efficiency is corrected using the factor 0.96, and the ratio w_{corr}/eff_{corr} is 0.5, then mass flow will be corrected with the factor 0.98.

Note that you can modify the Reynolds number correction data after selecting in the *Off-Design Input* window  (*Special*) from the *Maps and Connections* button group.

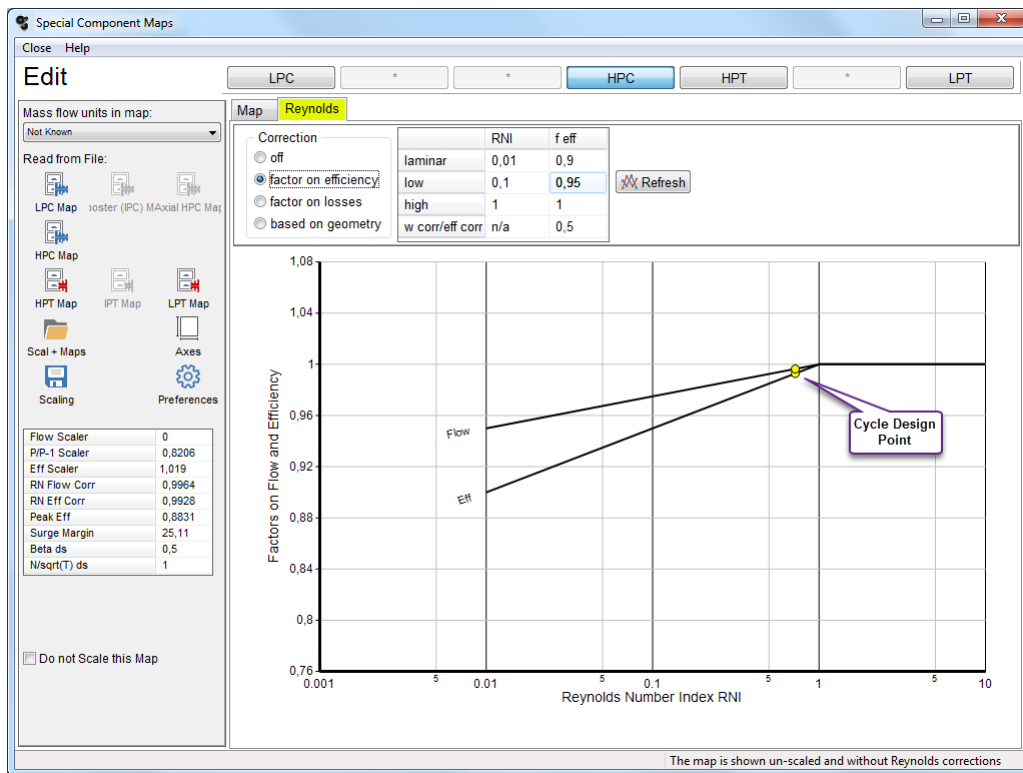

Modifications you make here can be stored in an engine model file (an option in the *Off-Design Input* window) and in a map scaling file (an option in the *Special Component Maps* window). When you read an engine model file then the Reynolds correction data from the engine model file will override the Reynolds correction data read from the component map file.

10.10 ... Increase Surge Margin

During an off-design calculation you may detect, that the surge margin in one of the compressors is not sufficient. You can cure this problem by **setting the design point** in the map to a lower β -value before commencing the off-design simulation. Alternatively, you can use variable geometry in your engine. Opening the nozzle of a mixed flow turbofan will increase fan surge margin, for example.



Note however, that this will not help if you have got a surge problem with the high-pressure compressor of your turbofan.

Another option is employing a handling bleed to lower the operating line of a compressor. You can define an [automatic schedule](#) for this bleed. Using variable turbine geometry is mostly not a practical thing to do, but can also help to alleviate compressor surge problems.

10.11 ... Use a Booster Map with an Unmixed Turbofan

Instead of the TWO SPOOL TURBOFAN configuration select the GEARED TURBOFAN A configuration, set the inner fan pressure ratio to 1.0 and use as gear ratio also 1.0. Enter the booster pressure ratio and the booster efficiency such that they include the fan hub pressure rise.

10.12 ... Select the Optimum Fan Pressure Ratio for Turbofan Engines

Some engines for subsonic transports have a mixer while others do not. There is a lot to be said for both versions. With GasTurb 13 you can study the consequences of mixing the core and the bypass streams. There are different criteria to be used for selecting the optimum fan pressure ratio.

Unmixed flow turbofan

Let us start with the unmixed engine. We want to design a low-pressure system for a given core engine. Which is the best combination of bypass ratio and fan pressure ratio? This problem can be solved analytically ([Reference 24](#)) and leads to the conclusion that the specific fuel consumption will be lowest when the ideal jet velocities V_{18} and V_8 are related to the low spool efficiencies according to

$$\left(\frac{V_{18,id}}{V_{8,id}} \right)_{opt} = \eta_{Fan} \cdot \eta_{LPT}$$

Note that this formula implies special definitions for both the jet velocities and the efficiencies. $V_{8,id}$ and $V_{18,id}$ are ideal velocities: they are calculated from a full expansion to ambient pressure. η_{Fan} takes into account all the bypass stream pressure losses, and η_{LPT} all the losses downstream of the low-pressure turbine.

Mixed flow turbofan

For the mixed flow turbofan there is also a rule for selecting the best combination of fan pressure and bypass ratios. At the mixer entry the ratio of the total pressures P_{16}/P_6 must be close to unity. Otherwise, there will be high mixing losses which will decrease the thrust gain as you can evaluate with GasTurb Details 6. Toward part load the pressure ratio P_{16}/P_6 increases. It is therefore good to select a value for P_{16}/P_6 which is slightly below 1 for the design point.

The optimum fan pressure ratio for a mixed flow engine is generally lower than that for an unmixed engine, provided that both have the same bypass ratio. If you compare engines with the same fan pressure ratio, the mixed flow engine will have a lower bypass ratio and a higher specific thrust F_N/W_2 . The amount of power which the low-pressure turbine has to supply to drive the fan will be smaller if both streams are mixed. This usually allows the mixed engine to be designed with one fewer LPT stage than the unmixed turbofan. The weight saved by removing this turbine stage helps to compensate for the higher weight of the long duct nacelle needed for the mixed flow engine.

10.13 ... Make a Turbine Temperature Schedule

In the *Off-Design Input* window click the  (*Schedules*) button in the *Controls* button group. Enter [numbers](#) for the schedule and activate it. After closing the schedule definition window you will see on the notebook page [Limiters](#) the activated limiters marked as scheduled.

If you need a control schedule in which T_{41} is not only a function of T_2 , but also a function of Mach number, for example, then you must employ a [General Table](#). Select *General Table...* from the menu in the schedule definition window to go to the table editor. After having created a tables in the editor (or loaded from file) you can select *HPT Rotor Inlet Temp T41* as parameter being a function of the value read from the table which is selectable from the list below the parameter selection list. Do not forget to activate the schedule before closing the control schedule definition window.

Even more complex control schedules can be described with the help of [composed values](#). The result for the composed value is finally employed as single valued [limiter](#).

10.14 ... Make Nozzle Area a Function of Corrected Speed

Click in the *Off-Design Input* window the  (*Schedules*) button in the *Controls* button group. Use as schedule parameter *Delta Nozzle Area [%]* being a function of *Corr. Spool Speed [%]*, enter your numbers and activate the schedule. Alternatively you can employ a [General Table](#) and iterate the nozzle area modifier (i.e. *Delta Nozzle Area [%]*) in such a way that the calculated nozzle area is equal to the value read from the table.

You can find an optimized nozzle area schedule easily. Define an iteration with *Delta Nozzle Area [%]* as variable and *Specific Fuel Consumption* as iteration target name. Use the keyword **min** instead of a value for the iteration target:

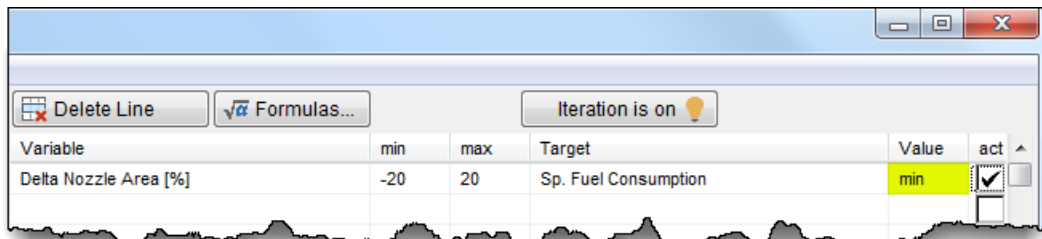

Run an *Operating Line* and then plot *Delta Nozzle Area [%]* over *Rel. Corr. Spool Speed*:

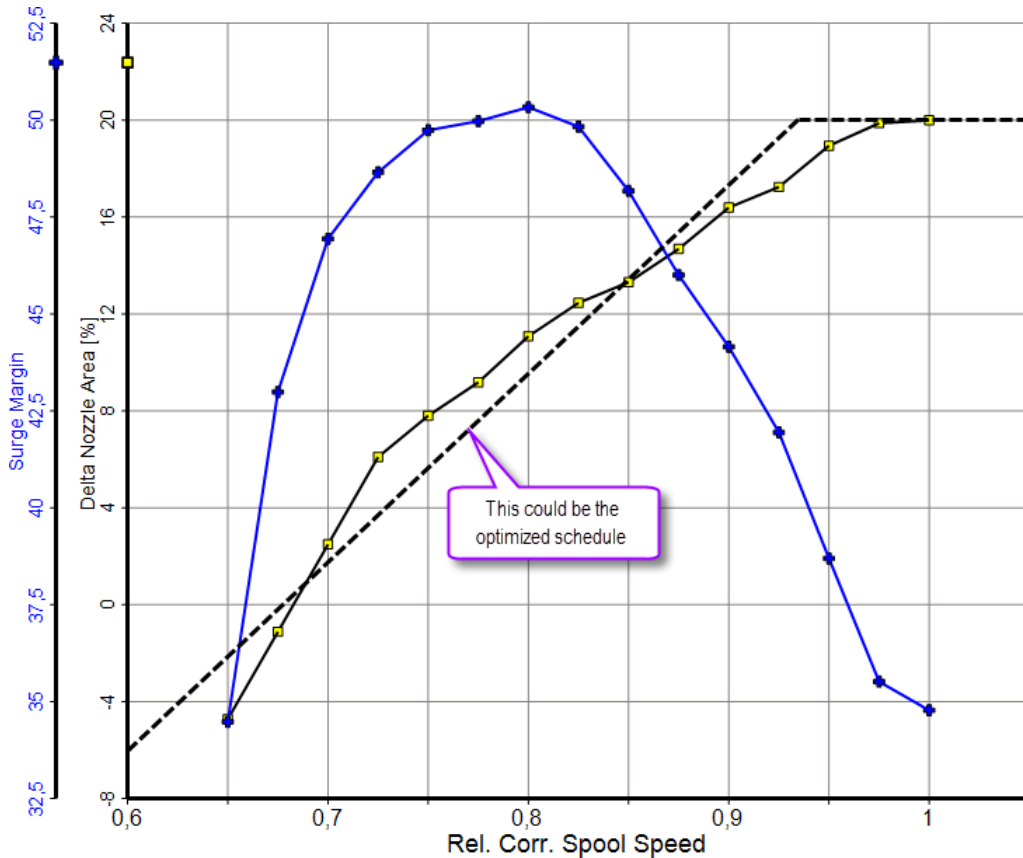

10.15 ... Estimate the Confidence of Achieving the Development Target

When a new engine is designed there is some uncertainty about the component performance that can be achieved and this transfers to an uncertainty in overall engine performance. If, for example, the design target in specific fuel consumption of the project is met with insufficient confidence then the cycle must be modified. That can often be done by an increase in the overall pressure ratio or in the bypass ratio, for example. The confidence with which the development targets are achieved can be improved to a certain extent with more time and money spent for engine development.

The *Monte Carlo* method applied to this problem can give an estimate about the exchange rate between confidence and development effort. The input data for such an exercise is derived from interviews with the component specialists as described in the section about [Engine Design Uncertainty](#).

A similar interview would be to ask firstly for the best value which the efficiency could assume. This value is interpreted as the 2σ limits of a normal distribution. That means, that only in 2.5% of all cases this value will be exceeded. Further questions are for the most probable value and for a pessimistic value which will be achieved in at least two thirds of all component designs. The answers can be checked for consistency: the difference between the most probable and the best value should be approximately twice as big as the difference between the most probable and the low value estimate.

The method is not only useful prior to the launch of a new engine project. During the development it can be used to correlate the confidence in the success of intended modifications with the probability of achieving the overall development target.

10.16 ... Analyse a Transient Test

If you have measured data from a transient test, then you can analyze them with the help of a transient simulation. First build a model which describes the steady state behavior of the engine, then go for the transient simulation. Use as input data the measured spool speed of the first compressor as a function of time. If the engine has a variable nozzle, then enter also A_8 data as a function of time.

During transient maneuvers there is a significant amount of heat transferred between the blades and casings and the gas. This effect can be modeled with GasTurb 13, however, such a model needs to be calibrated first. Before having calibrated the model you should not use fuel flow as an input because this would result in a wrong energy transfer to the gas stream.

Run the transient simulation with the above specified input and you will get as a result the transient operating lines in the compressor maps, among other useful information.

10.17 ... Simulate Water Injection into a Turbofan

For the TWO SPOOL MIXED TURBOFAN configuration you can study the effects of rain ingestion, inlet fogging and water injection upstream of the fan. The GEARED MIXED TURBOFAN A configuration allows for water injection into the core stream upstream of the booster, between the core compressors and into the burner. Water injection can be used for increasing the power of an engine and for NO_x reduction.

Water injected a certain distance upstream of the fan cools the air down because the water evaporates before it enters the engine. This process is called **inlet fogging**. Water injected directly in front of the fan has no chance evaporating before it enters the engine and we get a **wet compression** process.

The wet compression process is described with the empirical constant *Evaporation Rate $d\text{ war} / d\text{ Temp}$* . (here war = liquid water-air-ratio). In a first calculation step any wet compression process is calculated without considering the water. This calculation yields the polytropic efficiency. Using this polytropic efficiency the process is recalculated in 20 steps that each consist of a compression step followed by an evaporation step. The amount of water evaporating is calculated from the temperature increase during the compression step and the given *Evaporation Rate $d\text{ war} / d\text{ Temp}$* . Thus the amount of gaseous water in the air is continuously increasing while the amount of liquid water is decreasing.

When no liquid water is left, and the compression process is not yet finished, then the rest of the compression process is calculated with the then existing gaseous water-air-ratio.

If not all of the liquid water evaporates within the fan then the rest of the liquid water is transferred to the bypass respectively high pressure compressor HPC. If downstream of the HPC there is still liquid water then it will be evaporated before the burner calculation commences.

Liquid water at the bypass exit will evaporate after mixing the hot and the cold stream between stations 64 and 65. Note that the printout will show station 65 only if an evaporation of liquid water takes place.

The aim of injecting water into the core stream of a turbofan is increasing thrust and reducing emissions. You can study this with the GEARED MIXED FLOW TURBOFAN configuration. Note that in this simulation it is assumed that all the water evaporates before it enters the compressor. If the relative humidity - based on total pressure and temperature - exceeds 100% then a warning message appears. Note that in a more rigorous simulation the calculation of the relative humidity must employ the static pressure and temperature instead of the total quantities.



Limitations

In the simulation it is assumed that the water (either gaseous or liquid) is evenly distributed over the fan face. In a real engine the liquid water will tend to concentrate along the outer wall of the fan, the booster and the HPC. This is because the water droplets that hit the compressor blades will be accelerated to blade speed and then move along the blade surface outwards due to centrifugal force. Finally the droplets will leave the blades and many of them will hit the casing and create a water film. Some of the water moving along the casing will disappear in the offtakes that are located there. Water flowing through the handling bleed valve (if open) will enter the bypass channel.

As mentioned above GasTurb 13 assumes that the water is evenly distributed over the gas stream and thus the effects of local water concentrations is not taken into account.

Gas properties are stored in tables for dry air, air with 3% gaseous water-air-ratio and 10% gaseous water-air-ratio. Water flow rates caused by the incoming humidity, inlet fogging and water injection that yield together more than 10% water-air-ratio lead to extrapolation of the gas property data tables. It is up to the user of the program to decide whether the error introduced by this extrapolation of the gas property tables is acceptable or not.

10.18 ... Generate Data for Input to Aircraft Performance Calculation Programs

Aircraft performance calculation programs need as an input engine performance data in a specific sequence and format. You can produce these data with the help of GasTurb 13. If your aircraft performance program needs data that are not directly calculated by the program like relative thrust, for example, then make use of [composed values](#).

For generating the data the best solution is to create a [batch job](#). You can run an unlimited number of points in arbitrary sequence with this option.

10.19 ... Design an Engine for a Supersonic Aircraft

The design requirements for an engine of a supersonic aircraft are quite different to those of a subsonic transport aircraft engine. We will study the problem using the file **DEMO_MTF.CYM** which contains data for a low bypass ratio, mixed flow turbofan with reheat and a convergent-divergent nozzle.

There are several conflicting design requirements for such an engine. High specific thrust and low specific fuel consumption for supersonic flight are the most important criteria. We must also consider *Take Off* performance. Moreover, the specific fuel consumption for subsonic cruise conditions should not be too high. Fulfilling this latter criterion leads to a high bypass ratio engine, while fulfilling the first criterion mentioned favors a low bypass ratio. The choices you make very much depend on the mission the aircraft has to fulfill.

The example data file provides you with the cycle data at sea level static (SLS) conditions, which are shown in the following table. Note that the area ratio of the convergent-divergent nozzle A_9/A_8 is different for dry and reheated operation. In both cases the nozzle pressure ratio is too low for the given area ratio. The nozzle over-expands the flow, as you can see from the negative pressure thrust term. These and other details will appear on the output screen when you run the example. Note that you must adjust the nozzle area ratio when you switch from dry to reheated operation.

Bypass ratio	1
Burner exit temperature T_4	1600 K
Overall pressure ratio	17.325
Reheated thrust	48.6 kN
Nozzle inlet temperature in reheat T_7	2000 K
Nozzle area ratio in reheat $(A_9/A_8)_{RH}$	1.35
Dry thrust	29.4 kN
Nozzle area ratio in dry $(A_9/A_8)_{dry}$	1.2

We will now look at supersonic flight conditions. First calculate the design point with reheat switched on. Then select the off-design calculation option and use the standard component maps together with the *Booster Map Type = 0*. The area ratio A_9/A_8 of the convergent divergent nozzle in off-design depends on the nozzle throat area A_8 :

$$\frac{A_9}{A_8} = a + b \cdot \frac{A_8}{A_{8,Design}} + c \cdot \left(\frac{A_8}{A_{8,Design}} \right)^2$$

Use $a = 0.8705$, $b = 0.7325$ and $c = -0.253$. Then enter the following data and start the off-design calculation:

Altitude [m]	11000
Mach Number	2
HPC Spool Speed $ZXNH$	1.01

The table below contains the most important results for the two cases $A_8=A_{8,Design}$ and $A_8=A_{8,Design}+10\%$. For the nominal nozzle area, the mechanical spool speed of the gas generator N_H exceeds the sea level value (all design point speeds are defined as 100%), but the aerodynamic speed $N_H/\sqrt{\Theta_{25,R}}$ decreases to 91.9%. The relative aerodynamic speed of the fan $N_L/\sqrt{\Theta_{2,R}}$ drops to an even greater extent. This explains the overall pressure ratio of 10.5, which is quite low compared to the pressure ratio at sea level.

Property	$\Delta A_8=0\%$	$\Delta A_8=+10\%$
Thrust	46.9 kN	50.5 kN
Mass Flow W_2	52.1 kg/s	56.2 kg/s
Burner exit temperature T_4	1681 K	1672 K
Bypass ratio	1.21	1.36
Overall pressure ratio	10.5	10.6
Nozzle area ratio A_9/A_8	1.339	1.385



Property	$\Delta A_8=0\%$	$\Delta A_8=+10\%$
Nozzle pressure ratio P_8/P_{amb}	12.28	11.53
Low-pressure spool speed N_L	89.5 %	92.6 %
High-pressure spool speed N_H	101 %	101 %
Fan aerodynamic speed $N_L/\sqrt{\Theta_{2,R}}$	76.9 %	79.6%
HPC aerodynamic speed $N_H/\sqrt{\Theta_{25,R}}$	92.0%	91.9%

The result clearly shows that the standard map scaling procedure must not be applied if the cycle design point is at supersonic flight conditions. The standard procedure would place the design point at a corrected speed of 100% in all maps. If you run a sea level static flight case with such a cycle design, the operating point in the compressor maps would be found at excessively high aerodynamic spool speeds.

You can, of course, also use the standard component maps when defining your engine design point at supersonic flight conditions. You will then have to set the design point in the component maps to an appropriate map speed value significantly below 100%.

The table above contains two columns with numbers. Both apply to the same high pressure spool speed. A bigger nozzle area will improve performance in this case. Whether an increase in the nozzle area helps depends on the flight condition. To see this, take a look at a subsonic high altitude cruise case, for example.

For the calculation of dry performance at 11000m, Mach number 0.8 you need to enter some data in addition to the modified altitude and Mach number. Reset the nozzle area to 100%, switch on the $N_L/\sqrt{\Theta_{2,R}}$ limiter and set it to 104%. You can now start the calculation.

This specific iteration sometimes fails to converge. What can you do to get a valid solution? Restart the calculation, this might lead to convergence. If not, look on the *Iteration* page: you may find an unrealistic number for the estimated bypass ratio, for example. Correct it to BPR=1 to provide a revised estimate for the iteration. This should help; if it does not, have a look at the estimates for the other iteration variables and enter reasonable looking numbers.

Try also the high altitude subsonic flight case with the same two nozzle areas as above. You will find that - in contrast to the supersonic flight case with afterburning, in which the nozzle area increase yields higher thrust - increasing the nozzle area at this flight condition leads to a lower thrust. In the supersonic case the decrease in nozzle pressure ratio due to the bigger nozzle area is overcompensated by the increase in mass flow and therefore thrust increases. While flying with subsonic velocity at high altitude the corrected fan speed is limited and this prevents an increase in mass flow when opening the nozzle and the resulting drop in nozzle pressure ratio decreases thrust.



10.20 ... Investigate a Variable Cycle Engine

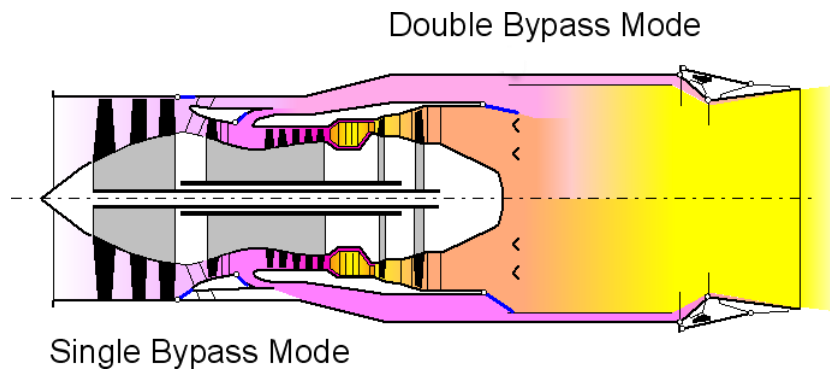

The variable cycle engine as modeled within GasTurb 13 has three *Variable Bypass Injector (VABI)* valves:

- downstream of the fan
- downstream of the core driven fan stage
- at the inlet to the mixer

During the cycle design calculation all three VABI's are in their nominal (open) position, i.e. as shown in the figure for the double bypass mode. In single bypass mode the front fan and the core driven fan stage operate in series. Note that the mixer VABI in single bypass mode may be open or closed as shown in the figure above.

For the two front VABI's only the values 0 (closed) and 1 (open) are accepted. The rear VABI is closed if the input value is set to zero.

At the cycle design point this VABI is in its nominal position, described by $VABI_3=1$. The numbers describing the other positions are in the range from 0.5 to 1.5. Values lower than one indicate that the bypass mixer area A_{163} is smaller than its nominal value. For example $VABI_3 = 0.5$ means that the bypass mixer area is reduced to 50% of the design point value. VABI 3 values bigger than one mean that the core mixer area A_{63} is reduced. A 50% reduction of A_{63} is described with $VABI_3 = 1.5$, for example. The sum of A_{163} and A_{63} is always equal to the total mixer area A_{64} .

For off-design operation the core driven fan stage must cope with a very wide flow range which requires variable geometry. The variable guide vane settings of the intermediate-pressure compressor going with the different VABI positions are separate input properties.

10.21 ... Speed up the Calculation

Extensive use of composed values in combination with user defined iterations can slow down the calculation considerably. You can minimize the calculation time by moving those [composed value definitions](#) that are iteration targets to the top of the list in the composed value definition list. Also the user defined limiters should be among the first composed values while they are activated.

10.22 ... Compare Temperature-Entropy and Enthalpy-Entropy Diagrams

When you have a *Temperature-Entropy* or *Enthalpy-Entropy* diagram on your screen then you can freeze this diagram by clicking the  (Freeze) button.

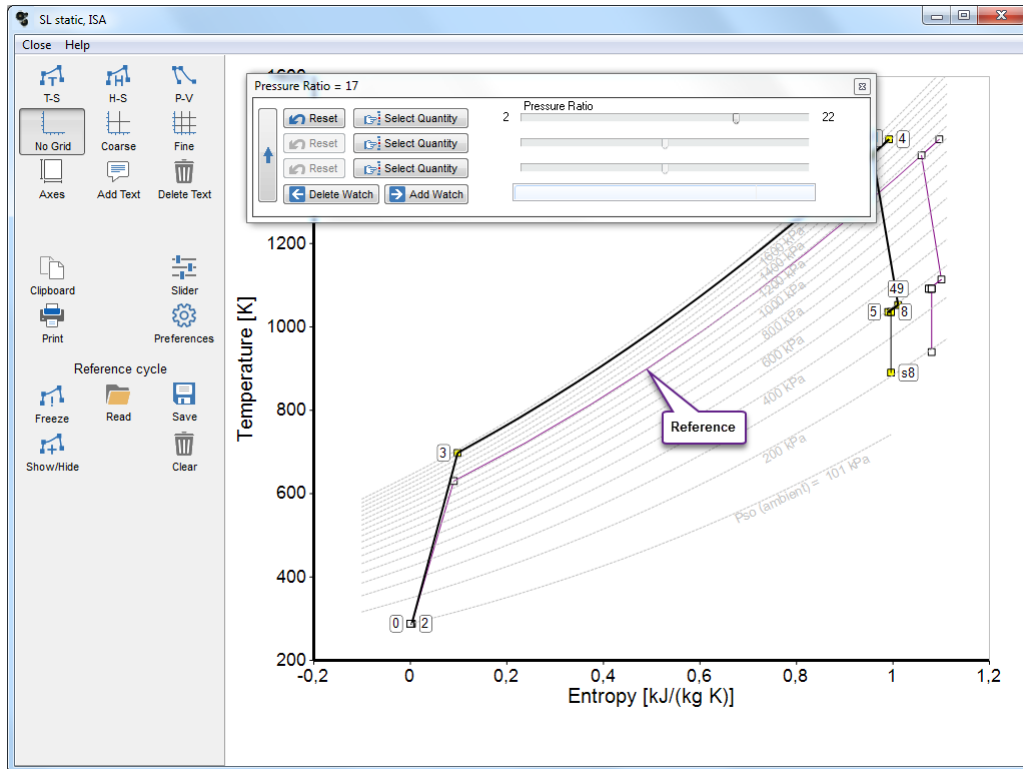

In the example above the compressor pressure ratio was assigned to a slider and increased relative to the reference cycle. The comparison of the two cycles shows how compressor pressure ratio changes affects the expansion process in the turbines.

10.23 ... Recover from a "General Error"

Severe errors in the input data will in some odd cases cause the following message to show up:

Your input data do not lead to a reasonable cycle. Please check and correct your data!

Check your data for typing errors, wrong units or wrong orders of magnitude. Look at the *Iterations* page in the *Off-Design Input* window and correct extreme estimates for the iteration variables. Take range warnings serious. The program can never calculate a cycle with a burner pressure ratio of 0.04, for example. You may have entered this number because you were thinking of a burner pressure loss of 4%.

10.24 ... Compile the Program

The first attempt to compile the GasTurb program usually ends with the error message:

Class THelpRouter not found. Ignore the error and continue?

This message indicates that a Delphi component is missing. The required components - which are needed for the GasTurb Help System - are part of the EC Software Help Suite (EHS); they can be downloaded for free from

<http://www.ec-software.com/comppage.htm>

Store the EHS components in a directory of your choice. Next select in Delphi *Project Options* and add on the page **Directories/Conditionals** the **Search Path** to this directory.

The next error message which many encounter is:

File not found: Excel_TLB.dcu

This message indicates that the *Excel Type Library* is not loaded. How type libraries are loaded is described in the Delphi help system; The *Excel Type Library* is copied to the computer as part of the *Delphi Integrated Development Environment* during the installation of Delphi.

Nomenclature and Units



XI



11 Nomenclature and Units

The first page of the cycle result sheet contains a summary in which many abbreviations and symbols are used. When you click on a symbol - just after the first letter - you will get an explanation:

The screenshot shows the 'Summary' window in GasTurb 13. The window title is 'Alt=11000m / Mn=0.800 ISA'. The left sidebar contains 'Overview', 'Diagrams', and 'Output' sections. The main area displays a table of station data and a list of nomenclature items.

Station	W kg/s	T K	P kPa	wRstd kg/s	FN
amb		216,65	22,632		= 3,16 kN
1	20,294	244,44	34,509		
2	20,294	244,44	34,164	55,436	
13	17,395	294,18	61,495	28,960	
21	2,899	326,63	85,410	3,662	
25	2,899	326,63	84,556	3,699	
3	2,812	599,69	591,890	0,694	
31	2,464	599,69	591,890		
4	2,524	1450,00	574,133	0,999	
41	2,698	1400,30	574,133	1,050	
43	2,698	1141,05	208,871		
44	2,843	1115,66	208,871		
45	2,843	1115,66	204,694	2,769	
49	2,843	781,91	37,991		
5	2,930	773,75	37,991	12,806	
8	2,930	773,75	37,231	13,067	
18	17,395	294,18	60,265	29,551	
Bleed	0,029	599,69	591,890		

Efficiencies:	isent	polytr	RNI	P/P
Outer LPC	0,9000	0,9079	0,409	1,800
Inner LPC	0,8900	0,9032	0,409	2,500
HP Compressor	0,8700	0,8994	0,719	7,000
Burner	0,9995			0,970
HP Turbine	0,8800	0,8666	0,892	2,749
LP Turbine	0,8810	0,8565	0,413	5,388

HP Spool	mech Eff	Nom Spd
	0,9900	38613 rpm
LP Spool	mech Eff	Nom Spd
	1,0000	13500 rpm

hum [%]	war0	FHV	Fuel
0,0	0,00000	43,124	Generic

Nomenclature list:

- TSFC = 18,9610 g/(kN*s)
- wF = 0,05987 kg/s
- BWF = Fuel Flow [kg/s] = 0,1042
- S_w = 0,1042
- Core Eff = 0,4683
- Prop Eff = 0,7529
- P3/P2 = 17,33
- P2/P1 = 0,9900
- P16/P13 = 0,9800
- P25/P21 = 0,9900
- P45/P44 = 0,9800
- P6/P5 = 0,9800
- A8 = 0,05700 m²
- A18 = 0,12549 m²
- P8/Pamb = 1,64505
- P18/Pamb = 2,66282
- wB1d/w25 = 0,01000
- CD8 = 0,97370
- CD18 = 0,97600
- XM8 = 0,88612
- XM18 = 1,00000
- V18/V8, id = 0,83347
- Loading = 100,00 %
- e444 th = 0,86221
- PWX = 50,00 kw
- wCHN/w25 = 0,06000
- wCHR/w25 = 0,05000
- wLc1/w25 = 0,03000

You will see the station definition on the *Air System* page and in the *Nomenclature* window which opens after a click on (*Stations*) in the *Extras* button group.

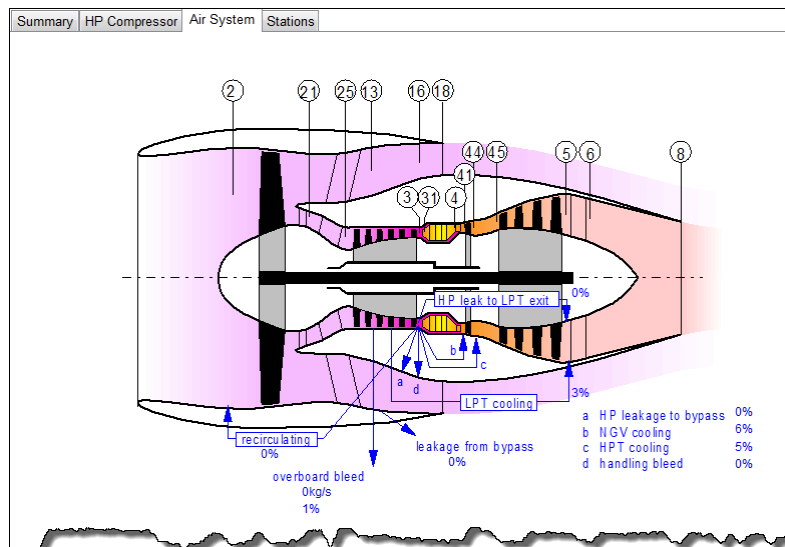

The exact location of the thermodynamic stations is shown in the engine drawing which is generated if the scope is *More*:

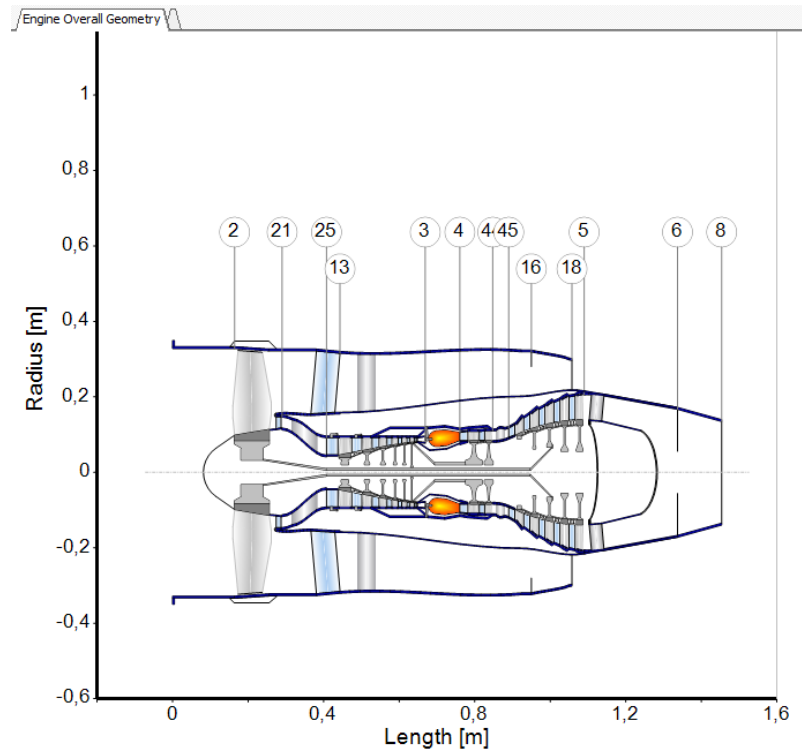

11.1 File Nomenclature

There are example data files delivered with the program, one for each engine configuration. The names of these example files begin with DEMO. The file extension is composed of three letters and always begins with the letter C which stands for cycle data. The next two letters are associated with the engine type. Cycle data for single spool turbojets, for example, have the file extension CYJ.

Engine model files have the same file extension as ordinary cycle data files except that the first letter is M. This file nomenclature has the advantage, that in file selection boxes only those files are offered for loading, which are compatible with the type of engine you are currently simulating.

Besides the data files GasTurb 13 employs files with the extension NMS. These engine configuration specific files contain the names of the properties, default values and step sizes, default [range borders](#) for checking input and output values and more. NMS files can be edited with the program GasTurb Names.

11.2 Station Designation

The station definition used in the program follows the international standard for performance computer programs. This standard has been published by the Society of Automotive Engineers SAE as ARP 755C.

The thermodynamic station names are defined as follows:

0	Ambient
1	Aircraft-engine interface
2	First compressor inlet
21	Inner stream fan exit
13	Outer stream fan exit



16	Bypass exit
161	Cold side mixer inlet
163	Cold side mixing plane
18	Bypass nozzle throat
24	Intermediate compressor exit
25	High-pressure compressor inlet
3	Last compressor exit, cold side heat exchanger inlet
31	Burner inlet
35	Cold side heat exchanger exit
4	Burner exit
41	First turbine stator exit = rotor inlet

Two spool engines:

43	High-pressure turbine exit before addition of cooling air
44	High-pressure turbine exit after addition of cooling air
45	Low-pressure turbine inlet
49	Low-pressure turbine exit before addition of cooling air

Three spool engines:

42	High-pressure turbine exit before addition of cooling air
43	High-pressure turbine exit after addition of cooling air
44	Intermediate turbine inlet
45	Intermediate turbine stator exit
46	Intermediate turbine exit before addition of cooling air
47	Intermediate turbine exit after addition of cooling air
48	Low-pressure turbine inlet
49	Low-pressure turbine exit before addition of cooling air
5	Low-pressure turbine exit after addition of cooling air
6	Jet pipe inlet, reheat entry for turbojet, hot side heat exchanger inlet
61	Hot side mixer inlet
63	Hot side mixing plane
64	Mixed flow, reheat entry
7	Reheat exit, hot side heat exchanger exit
8	Nozzle throat
9	Nozzle exit (convergent-divergent nozzle only)

The station numbers for the selected configuration are shown in an engine cross section. This cross section may be printed from the cycle design point result window.

11.3 Symbols

The symbols for mass flow, pressures and other quantities are defined in ARP 755. This standard has been published by the Society of Automotive Engineers SAE. The symbols are composed of the station name and some leading letters. The following symbols are used in the manual and the program:

A	Area
alt	Altitude
amb	Ambient

ax	Axial
Bld	Bleed
BPR	Bypass ratio
corr	Corrected
C	Constant value, coefficient
C	Compressor
CFG	Thrust coefficient
Cl	Cooling
d	Diameter
dH	Enthalpy difference
dp	Design point
DC	Pressure distortion coefficient
DT	Temperature distortion coefficient
f	Factor
f	Fuel
far	Fuel-air-ratio
F	Thrust
FN	Net thrust
FG	Gross thrust
h	Enthalpy
H	High-pressure spool
Hd Bld	Handling bleed
HPC	High-pressure compressor
HPT	High-pressure turbine
i	Inner
IPC	Intermediate-pressure compressor (booster)
L	Low-pressure spool
Lk	Leakage
LPC	Low-pressure compressor (fan)
LPT	Low-pressure turbine
M	Mach number
N	Spool speed
NGV	Nozzle guide vane (of a turbine)
o	Outer
P	Total pressure
prop	Propulsion
PW	Shaft power
R	Gas constant
rel	Relative
RH	Reheat (afterburner)
RNI	Reynolds number index
s	Static
S NOx	NOx severity parameter (used for NOx emission estimates)
SD	Shaft, delivered
SFC	Specific fuel consumption
t	Tip (blade)
t	Time
T	Total temperature
TRQ	Torque
U	Blade (tip) velocity
V	Velocity
W	Mass flow
XN	Relative spool speed



11.4 Short and Long Names

GasTurb 13 uses two sorts of names for the properties: the short name and the long name:

Short name	Long name
alt	Altitude
dtamb	Delta T from ISA
humid	Relative Humidity [%]
XM	Mach Number
ZW2Rstd	Inlet Corr. Flow W2Rstd
P2q1	Intake Pressure Ratio
ZP3q2	Pressure Ratio
T4_D	Burner Exit Temperature
FN	Net thrust
WF	Fuel Flow

In the user interface usually the long names are used. In some cases, however, the use of the long names is not appropriate, as for example in the definition of [composed values](#) and in tables with results from a [Small Effects](#) study. Note that both the short and the long names are case sensitive.

11.5 Units

With GasTurb 13 you can use either SI units or Imperial (US custom) units. Switch between them while you define your cycle design point. During off-design simulations you may switch (click the  (*Options*) button in the *Extras* button group) between degree K and C while SI units are selected and between R and F while Imperial units are selected.

Property	SI	Imperial
Altitude	m	ft
Temperature	K or C	R or F
Pressure	kPa	psi
Mass Flow	kg/s	lbm/s
Shaft Power	kW	hp
Thrust	kN	lbf



Property	SI	Imperial
SFC (Thrust)	g/(kN s)	lbm/(lbf h)
SFC (Shaftpower)	kg/(kW h)	lbm/(hp h)
Velocity, Spec.Thrust	m/s	ft/s
Area	m ²	in ²
Diameter	m	in
Spec.Work H/T	J/(kg K)	BTU/(lbm R)
A*N ²	m ² RPM ² 10-6	in ² RPM ² 10-6
Tip Clearance	mm	in*10-3(=mil)
Torque	N*m	lbf*ft
Specific Shaftpower	kW/(kg/s)	hp/(lbm/s)

The units employed when evaluating the [composed values](#) are selected in the *Define Composed Values* window. They are independent from the units used for the other data in- and output. The reason for that is that GasTurb 13 is unable to convert the results of the composed value formulas to a different system of units.

11.6 Total Pressure

For a thermodynamic cycle calculation the true (static) pressure is of relevance mostly for the intake and the nozzle, but usually not for the engine components. What matters is the total or stagnation pressure.

The stagnation pressure is the pressure which the gas would possess when brought to rest isentropically. The symbol for total pressures is P followed by the [station designation](#) number. Static pressures are marked as P_s. The symbol for ambient pressure is P_{amb}.

11.7 Total Temperature

For a thermodynamic cycle calculation the true (static) temperature is usually of no relevance. What matters is the total or stagnation temperature.

The stagnation temperature is the temperature which the gas would possess when brought to rest adiabatically. The symbol for total temperatures is T followed by the [station designation](#) number. Static temperatures are marked as T_s. The symbol for ambient temperature is T_{amb}.



11.8 Further Definitions

11.8.1 GasTurb Deck

A GasTurb Deck is a computer deck as defined in the SAE Aerospace Standard AS681. The engine subroutine is contained in a Dynamic Link Library (DLL). The Dynamic Link Library can be used with any other 32-bit Windows program, independent from the programming language of the calling program.

The data describing the engine are created with GasTurb as an *Engine Model File* which is loaded during the deck initialization process. During this initialization process the cycle design point is calculated with the scope *Performance*, all the component maps are loaded and scaled appropriately. Then the engine model is ready for off-design simulations.

11.8.2 Heat Rate

According to the Diesel & Gas Turbine Worldwide Catalog is the *Heat Rate* a product of *Lower Heating Value of Fuel* (measured in kJ/g) multiplied by shaft power *Specific Fuel Consumption* (measured in g/kWh).

In GasTurb 13 the following units are standard:

Units	SI	US
FHV	MJ/kg	BTU/lbm
SFC (Shaftpower)	kg/(kw h)	lbm/(hp h)

11.8.3 Stator Outlet Temperature

The *Stator Outlet Temperature* SOT (=T41) is the total temperature at the exit of the first vane row of the turbine, after mixing the stator cooling flow with the main stream. The *Stator Outlet Temperature* is in GasTurb equal to the *Rotor Inlet Temperature* **RIT** because no cooling air is mixed in between the stator outlet and the rotor inlet.

The first stator of a turbine is also called *Nozzle Guide Vane* NGV because it accelerates the flow like a nozzle.

11.8.4 Rotor Inlet Temperature

The Rotor Inlet Temperature RIT is the total temperature after mixing the cooling air of the turbine inlet guide vane to the mainstream. The mass flow at the rotor inlet is assumed to do work in the turbine while expanding with the specified *turbine efficiency*.

11.8.5 Standard Day Conditions

The (sea level) standard day conditions are $T = 288.15\text{K}$ and $P = 101.325\text{ kPa}$. The gas constant of dry air is $287.05\text{ J/(kg}\cdot\text{K)}$



11.8.6 Spool Speed

For many questions the spool speeds are of interest with gas turbine performance simulations.

You can calculate the *design point spool speed* N, RPM in revolutions per minute from a few data at the compressor inlet, see [compressor design](#). The design point spool speed is required for the simulation of inlet flow distortion and transients.

For off-design simulations there are four different values for the spool speed:

N	actual spool speed
$N, nominal$	nominal spool speed
N, rel	relative spool speed
$N, corr, rel$	relative corrected spool speed

The *relative spool speed* is defined as $N, rel = N / N, ds$ with $N, ds = 1.0$ at the cycle design point. The *actual spool speed* is $N = N, rel * N, nominal$

The *relative corrected spool speed* is defined as

$$N_{corr,rel} = \frac{N / \sqrt{\frac{R \cdot T}{R_{std} \cdot T_{std}}}}{\left(N / \sqrt{\frac{R \cdot T}{R_{std} \cdot T_{std}}} \right)_{ds}}$$

The index std indicates [standard day](#) conditions. For the cycle design point the relative corrected speed is per definition 1.0.

$N, nominal$ is an input on the compressor design page. It is a good idea to set the nominal speed to the design point spool speed value which has been calculated from the [compressor design](#) option, but that is not a "must".

As a standard for the cycle design point all relative and all relative corrected spool speeds are set to 1.0. However, when you [use an unscaled map](#) this might not be so.

11.8.7 Corrected Flow

Corrected flow is defined as

$$W_{corr} = W \cdot \frac{\sqrt{\frac{R \cdot T}{R_{std} \cdot T_{std}}}}{\frac{P}{P_{std}}}$$

with

W	Mass flow
T	Total temperature
P	Total pressure
R	Gas constant
T_{std}	Standard day temperature



- P_{std} Standard day pressure
 R_{std} Gas constant of dry air

11.8.8 Aircraft Speed

Various definitions for the speed of an aircraft are in use:

True Airspeed

The speed of the aircraft's center of gravity with respect to the air mass through which it is passing.

GasTurb 13 employs the true airspeed.

Indicated Airspeed

The speed indicated by a differential-pressure airspeed indicator which measures the actual pressure difference in the pitot-static head. This instrument is uncorrected for instrument, installation and position errors. For this reason it is often called pilot's indicated airspeed.

GasTurb 13 does not calculate the indicated airspeed. If you need it you must employ a composed value.

Calibrated Airspeed

The airspeed related to differential pressure by the standard adiabatic formulae. At standard sea level conditions the calibrated airspeed and true airspeed are the same. The calibrated airspeed can be thought of as the indicated airspeed, corrected for instrument errors. It is sometimes called true indicated airspeed.

GasTurb 13 does not calculate the calibrated airspeed. If you need it you must employ a composed value.

Equivalent Airspeed

The equivalent airspeed is a direct measure of the incompressible free stream dynamic pressure. It is defined as the true airspeed multiplied by the square root of the density ratio (air density at some flight altitude over density at sea level). Physically the equivalent airspeed is the speed which the aircraft must fly at some altitude other than sea level to produce a dynamic pressure equal to a dynamic pressure at sea level. At low speeds the calibrated airspeed and the equivalent airspeed are the same. For speeds above Mach 0.3 the two differ because of an error in the differential-pressure measuring device. This error is due to the compressibility of the air at higher speeds which cannot be calibrated into the instrument.

GasTurb 13 employs the equivalent airspeed.

11.8.9 Entropy Function

The well known formula for the end temperature of an isentropic compression is

$$T_{2is} = T_1 \cdot \left(\frac{P_2}{P_1} \right)^{\frac{\gamma-1}{\gamma}}$$

This equation is strictly valid for constant isentropic exponent γ only. The formula is often used with γ as a function of the mean temperature $(T_{2s}+T_1)/2$. The evaluation of the simple formula needs iteration with a result which is only an approximation.

The rigorous expression for an isentropic process with temperature dependent gas properties employs the entropy function Ψ which is defined as entropy divided by gas constant R :

$$\Psi(T) = \int_{T_{ref}}^T \frac{c_p}{R} \frac{dT}{T}$$

The change of the entropy function in an isentropic process is equal to the logarithm of the pressure ratio:

$$\Psi_2 = \Psi_1 + \ln(P_2/P_1)$$

Ψ can be tabulated as a function of temperature and reading this table with given Ψ yields the end temperature of any isentropic process without iteration.

11.8.10 Exergy

Exergy is defined as the maximum work obtainable from a thermodynamic system by bringing it into equilibrium with its environment, i.e. with the ambient conditions. In GasTurb the specific exergy e is calculated from specific enthalpy h and specific entropy s for each of the thermodynamic stations employing total temperature and pressure at the respective station and the (static) ambient temperature and pressure values:

$$e = h - h_{amb} - T_{amb} \cdot (s - s_{amb})$$

Exergetic efficiency of a system relates the change in exergy to the total energy (shaft power + heat) added to the system. In case of a compressor, for example, the exergetic efficiency is

$$\eta_{c,e} = \frac{e_3 - e_2}{dh_{23}}$$

Note that exergetic efficiency is not a pure measure of the compressor quality, it depends also on the compressor inlet conditions which in turn depend on flight and operating conditions.

In case of the burner of a conventional gas turbine it becomes especially obvious that exergy efficiency does not describe alone the quality of a component; it also describes the quality of the thermodynamic process. Even if the burner has no losses at all, i.e., if there is no pressure loss and the burning process yields perfect chemical equilibrium, the number calculated for exergetic efficiency remains well below 1. The majority of the exergy losses are due to the type of the heat addition process (i.e. at basically constant pressure) in a conventional gas turbine. The exergy losses could theoretically be reduced by switching over to constant volume respectively pressure rise combustion. The problem with these alternatives is that they result in highly unsteady flow which cause - relative to a steady flow - additional losses in the components downstream of the heat addition device.

Nevertheless the concept of exergy gives a hint to theoretically feasible gas turbine cycle improvements.

When calculating the exergetic efficiency of a complete aircraft propulsion system it is convenient to relate the exergy change to the product of fuel flow W_f and fuel heating value FHV. For the example



of a simple turbojet without power or bleed air offtake (i.e. $W_9=W_2+W_f$) the internal exergetic efficiency is

$$\eta_e = \frac{(1 + far) \cdot e_9 - e_2}{far \cdot FHV}$$

with $far=W_f/W_2$. It is a measure of how much of the fuel exergy is stored in the exhaust mass flow for producing thrust and therefore a measure of the internal quality of the jet engine. In contrast to thermal efficiency the internal exergetic efficiency not only includes the kinetic energy increase of the flow through the engine but also the available energy of the flying system relative to ambient pressure and temperature.

Additionally one can define overall exergetic efficiency as the ratio of propulsive power $F \cdot V_0$ and fuel exergy $W_f \cdot e_f$. It is a measure of how much of the fuel exergy is transferred to useful power and therefore the most general and most important measure of the quality of the whole system. In summary, exergetic efficiency is suited for describing the quality of a complete system operating in given ambient conditions, but not for qualifying the performance of isolated components of conventional gas turbines.

11.8.11 Relative Enthalpy Rise

The relative enthalpy rise of bleed air is a number between 0 and 1:

- If the relative enthalpy rise is equal to 0 then the bleed is taken upstream of the relevant compressor.
- If the relative enthalpy rise is equal to 1 then the bleed is taken downstream of the relevant compressor.
- If the relative enthalpy rise is between 0 and 1 then the bleed air is taken from an intermediate compressor stage. The number says how much energy was required to compress the air up to the offtake position.

An example: If you take off some bleed air after the third stage from a compressor which has five stages, then the relative enthalpy of the bleed air is $3/5=0.6$.

11.8.12 Equivalent Shaft Power

In a turboshaft engine the exhaust velocity is minimized and thus the maximum amount of power is extracted from the gas available from the gas generator.

Turboprop engines do not extract all the power from the exhaust gases since the exhaust gases create usable thrust. The optimum exhaust gas velocity depends from the flight velocity and the quality of the propeller. The higher the flight velocity the higher the optimum exhaust gas velocity. Poor propeller efficiency also favors high exhaust velocity.

When a turboprop engine is to be compared to a turboshaft engine then the equivalent shaft power of the turboprop is of interest. This shaft power is calculated as if the power turbine would expand to a total pressure which is equal to ambient pressure.

11.8.13 Turbine Flow Capacity

The background of the term turbine flow capacity is that in the throat of the nozzle guide vane of a turbine, the flow velocity is usually sonic or very near to sonic. For sonic flow the quantity $W \cdot \sqrt{T}$

(A*P) is a function of the gas constant and the isentropic exponent only. When the gas properties are known then it is sufficient to measure the turbine throat area to evaluate the term $W \cdot \sqrt{T}/P$ which is called the turbine flow capacity.

11.8.14 Heat Exchange Effectiveness

Heat exchange effectiveness is defined as ratio of actual transferred heat Q and the maximum transferable heat Q_{max} :

$$\varepsilon = \frac{Q}{Q_{max}}$$

The actual amount of heat transferred is the product of mass flow W , specific heat c_p and a temperature difference. Index c stands for the cold side and index h for the hot side:

$$Q = W_c \cdot c_{p,c} \cdot (T_{exit,c} - T_{inlet,c}) = W_h \cdot c_{p,h} \cdot (T_{exit,h} - T_{inlet,h})$$

The product of mass flow and specific heat is called a heat capacity flow

$$C_c = W_c \cdot c_{p,c}$$

$$C_h = W_h \cdot c_{p,h}$$

The maximum transferable amount of heat is

$$Q_{max} = \min \left\{ \begin{array}{l} C_c \cdot (T_{inlet,h} - T_{inlet,c}) \\ C_h \cdot (T_{inlet,h} - T_{inlet,c}) \end{array} \right\} = C_{min} \cdot (T_{inlet,h} - T_{inlet,c})$$

Effectiveness is then

$$\varepsilon = \frac{C_c \cdot (T_{exit,c} - T_{inlet,c})}{C_{min} \cdot (T_{inlet,h} - T_{inlet,c})} = \frac{C_h \cdot (T_{inlet,h} - T_{exit,h})}{C_{min} \cdot (T_{inlet,h} - T_{inlet,c})}$$

11.8.15 AnSyn Factor

The term *AnSyn* stands for *Analysis by Synthesis* which means model based performance analysis. In a model based test analysis the measured data are compared with those from a thermodynamic model of the engine.

AnSyn factors describe the difference between the off-design simulation model and quantities derived directly or indirectly from measurements. The *AnSyn* factor for efficiency is defined as

$$f_{AnSynE} = \text{measured efficiency} / \text{model efficiency}$$

Similarly, the flow capacity *AnSyn* factor is defined as

$$f_{AnSynC} = \text{measured corrected flow} / \text{model corrected flow}$$

For each compressor respectively turbine there is a flow capacity and an efficiency factor defined. Similarly an *AnSyn* Factor can be calculated from the difference between measured and calculated thrust of a jet engine, for example. It depends on the engine configuration which *AnSyn* factors are used during test analysis.



11.8.16 Propulsive Efficiency

Propulsive efficiency is the ratio of useful propulsive energy – the product of thrust and flight velocity – compared to the wasted kinetic energy of the jet:

$$\eta_P = \frac{F \cdot V_0}{W_9 \cdot (V_9^2 - V_0^2)/2}$$

If the nozzle flow is expanded fully to ambient conditions and the inlet mass flow W_0 is equal to the nozzle mass flow W_9 then thrust F equals $W \cdot (V_9 - V_0)$ and the above formula can be rewritten as

$$\eta_P = \frac{2 \cdot V_0}{V_0 + V_9}$$

Propulsive efficiency is maximum when jet velocity equals flight velocity; however, in this case thrust is zero.

With a turbojet at subsonic flight conditions the exhaust jet velocity is very much higher than the flight velocity of the aircraft. The high kinetic energy which the exhaust jet has relative to the air is a loss and this results in poor propulsive efficiency and finally in high thrust specific fuel consumption (SFC) even if all the component efficiencies are high.

When propulsive efficiency is evaluated for an unmixed flow turbofan then the core stream and the bypass stream must be considered. This is done by calculating the exhaust velocity V_9 as gross thrust divided by the sum of the two nozzle mass flows.

$$\eta_P = \frac{2}{1 + \frac{F_N + W_{2A} \cdot V_0}{(W_8 + W_{18}) \cdot V_0}}$$

See also [overall efficiency](#).

11.8.17 Thermal Efficiency

Thermal efficiency is defined as increase of the kinetic energy of the gas stream passing through the engine by the amount of heat employed which is given as product of fuel mass flow W_f and fuel heating value FHV:

$$\eta_{th} = \frac{W_9 \cdot V_9^2/2 - W_0 \cdot V_0^2/2}{W_f \cdot FHV}$$

With turbofan engines one can split the thermal efficiency in two terms, the [core efficiency](#) and the [transmission efficiency](#).

See also [overall efficiency](#).

11.8.18 Core Efficiency

Core efficiency is the ratio of energy available after all the power requirements of the core stream compression processes are satisfied – that means at the core exit - and the energy available from the fuel:

$$\eta_{core} = \frac{W_{core} \cdot (dh_{is} - V_0^2/2)}{W_f \cdot FHV}$$

The enthalpy difference dh_{is} is evaluated assuming an isentropic expansion from the state at the core exit to ambient pressure.

See also [overall efficiency](#).

11.8.19 Transmission Efficiency

Transmission efficiency describes the quality of the energy transfer from the core stream to the bypass stream. It is defined as ratio of the energy at the nozzle(s) to the energy at the core exit and is equal to the [thermal efficiency](#) divided by [core efficiency](#). Transmission efficiency is dominated by the efficiencies of the fan and the low pressure turbine, and both efficiencies are equally important.

See also [overall efficiency](#).

11.8.20 Overall Efficiency

The overall efficiency is the ratio of useful work done in overcoming the drag of the airplane to the energy content of the fuel:

$$\eta_o = \frac{F \cdot V_0}{W_f \cdot FHV}$$

With the same simplifying assumptions as made with the propulsive efficiency it follows that overall efficiency of a turbofan is equal to the product of [thermal efficiency](#) - which can be split into [core efficiency](#) and [transmission efficiency](#) - and [propulsive efficiency](#).

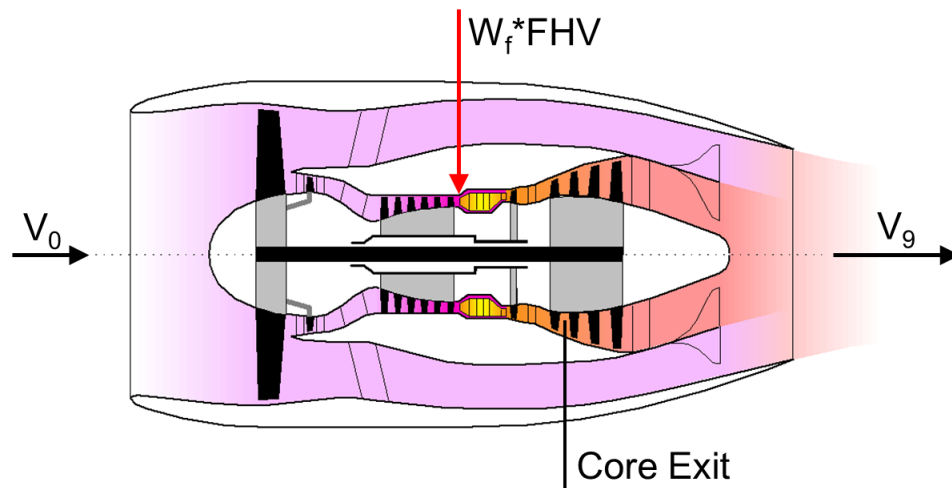



$$\begin{aligned}
 \text{Thermal Efficiency} &= \frac{\text{Energy at the Nozzle}}{\text{Energy of the Fuel}} \\
 \text{Core Efficiency} &= \frac{\text{Energy at Core Exit}}{\text{Energy of the Fuel}} \\
 \text{Trans. Efficiency} &= \frac{\text{Energy at the Nozzle}}{\text{Energy at Core Exit}} \\
 \text{Propulsive Efficiency} &= \frac{\text{Useful Work of the Engine}}{\text{Energy at the Nozzle}} \\
 \text{Overall Efficiency} &= \text{Thermal Eff.} \cdot \text{Propulsive Eff.} \\
 &= \text{Core Eff.} \cdot \text{Trans. Eff.} \cdot \text{Propulsive Eff.}
 \end{aligned}$$

The efficiency of an aircraft engine is inseparably linked with the flight velocity as can be seen from the definitions listed above. So the question arises, how to compare the quality of engines being used at different flight speeds.

We introduce the specific fuel consumption $SFC = W/F$ into the formula above and get:

$$\eta_o = \frac{V_0}{SFC \cdot FHV}$$

or

$$SFC = \frac{V_0}{\eta_o \cdot FHV} = \frac{V_0}{\eta_{th} \cdot \eta_P \cdot FHV} = \frac{V_0}{\eta_{core} \cdot \eta_{trans} \cdot \eta_P \cdot FHV}$$

11.8.21 Peak Efficiency

The peak efficiency is the highest efficiency found on a speed line in a compressor respectively turbine map. The peak efficiency of the map is the highest efficiency found on any speed line.

Acknowledgements





12 Acknowledgements

Some advice about basic Delphi functionality was found in the internet or in Delphi books authored by Marco Cantù, for example. Two Delphi units contain code written by others:

- The Delphi GDI+ Library Copyright (C) 2009 by Erik van Bilsen is the basis for all graphics in GasTurb 13.
- The steam property routines (Copyright (C) by Florian Schmidt, Institut für Luftfahrtantriebe (ILA), Universität Stuttgart, Germany) are employed in combined cycle calculations

References





13 References

- [1] P. P. Walsh, P. Fletcher
Gas Turbine Performance
Blackwell Science Ltd, 1998
- [2] J. Kurzke
Performance modeling methodology: Efficiency definitions for cooled single and multistage turbines
ASME paper 2002-GT-30497 presented at the Turbo Expo 2002 in Amsterdam
- [3] Arthur J. Glassman
Users Manual for Updated Computer Code for Axial Flow Compressor Conceptual Design
NASA Contractor Report 189171, 1992
- [4] Arthur J. Glassman
Computer Program for Preliminary Design Analysis of Axial Flow Turbines
NASA TN D-6702, 1972
- [5] J.L.Younghans, J.E.Johnson, S.J-Csonka
A Methodology to Assess Uncertainty in Selecting Affordable Gas Turbine Technology
ASME 94-GT-419, 1994
- [6] J. Kurzke
Some Applications of the Monte Carlo Method to Gas Turbine Performance Simulations
ASME 97-GT-48, 1997
- [7] J. Kurzke
Calculation of Installation Effects within Performance Computer Programs
in AGARD Lecture Series 183 "Steady and Transient Performance Prediction of Gas Turbine Engines", 1992
- [8] Committee of Aeronautical Technologies, Aeronautics and Space Engineering Board,
Commission on Engineering and Technical Systems, National Research Council
Aeronautical Technology for the Twenty-First Century
National Academy Press, Washington, D.C. 1992
- [9] A. Wulff, J. Hourmouziadis
A Universal Combustor Model for the Prediction of Aeroengine Pollutant Emissions
ISABE 99-7162, 1999
- [10] H.G. Münzberg, J. Kurzke
Gasturbinen - Betriebsverhalten und Optimierung
Springer-Verlag Berlin Heidelberg New York, 1977
- [11] Warner L. Stewart
A Study of Axial-Flow Turbine Efficiency Characteristics in Terms of Velocity Diagram Parameters
ASME 61-WA-37, 1961
- [12] Sanford Gordon and Bonnie J. McBride
Computer Program for Calculation of Complex Chemical Equilibrium Compositions and Applications
I. Analysis
NASA Reference Publication 1311, October 1994
- [13] Bonnie J. McBride and Sanford Gordon
Computer Program for Calculation of Complex Chemical Equilibrium Compositions and Applications

II. Users Manual and Program Description

NASA Reference Publication 1311, June 1996

[14] J. P. Longley, E. M. Greitzer

Inlet Distortion Effects in Aircraft Propulsion System Integration

in: AGARD Lecture Series 183, 1992

[15] J. Kurzke

Effects of Inlet flow Distortion on the Performance of Aircraft Gas Turbines

ASME GT2006-90419, 2006

[16] J. Kurzke

Model Based Gas Turbine Parameter Corrections

ASME GT2003-38234, 2003

[17] H.S. Wainauski, C. Rohrbach, T.A. Wynosky

Prop-Fan Performance Terminology

SAE Technical Paper 871838, 1987

[18] H.G. Jacob

Rechnergestützte Optimierung statischer und dynamischer Systeme

Fachberichte Messen - Steuern - Regeln, Springer Verlag 1982

[19] H. G. Münzberg

Flugantriebe

Springer Verlag, 1972

[20] C. Riegler, M. Bauer, J. Kurzke

Some Aspects of Modelling Compressor Behaviour in Gas Turbine Performance Calculation

ASME 2000-GT-0574

[21] J. Kurzke

Advanced User-Friendly Gas Turbine Performance Calculations on a Personal Computer

ASME 95-GT-147, 1995

[22] J. Kurzke

How to Get Component Maps for Aircraft Gas Turbine Performance Calculations

ASME 96-GT-164, 1996

[23] J. Kurzke

Gas Turbine Cycle Design Methodology: A Comparison of Parameter Variation with Numerical Optimization

ASME 98-GT-343, 1998

[24] N. Gasparovic

Das Zweistromtriebwerk bei optimaler und nicht-optimaler Auslegung

Forsch. Ing.-Wesen 42 (1976) Nr.5

[25] R. C. Kelahan, J. L. Gaddy

Application of the adaptive random search to discrete and mixed integer optimization

International Journal for Numerical Methods in Engineering, Vol. 12, 289-298 (1978)

[26] A. Schäffler

Experimental and Analytical Investigation of the Effects of Reynolds Number and Blade Surface Roughness on Multistage Axial Flow Compressors

ASME 79-GT-2, 1979

[27] Philip Hill, Carl Peterson

Mechanics and Thermodynamics of Propulsion



2nd Edition
Addison Wesley Longman, 2010

[28] Arthur H. Lefebvre, Dilip R. Ballal
Gas Turbine Combustion, Alternative Fuels and Emissions
3rd Edition
CRC Press 2010

[29] **NEWAC Technology Brochure**
www.newac.org

[30] J. Kurzke
An Enhanced Off-Design Performance Model for Single Stage Fans
ASME GT2014-26449, 2014

[31] H. Grieb
Projektierung von Flugtriebwerken
Birkhäuser Verlag 2004

[32] J. D. Denton
Loss Mechanisms in Turbomachines
ASME Journal of Turbomachinery, Vol. 115(4), 1993

[33] D. K. Hall, E. M. Greitzer, C. S. Tan
Performance Limits of Axial Compressor Stages
ASME GT2012-69709, 2012

[34] H. Grieb
Verdichter für Turbo-Flugtriebwerke
Springer Verlag 2009

[35] H. Grieb, G. Schill, R. Gumucio
A Semi-Empirical Method for the Determination of Multistage Axial Compressor Efficiency
ASME 75-GT-11, 1975

[36] Holloway, P. R., Koch, C. C., Knight, G. L., and Shaffer, S. L.
Energy Efficient Engine. High Pressure Compressor Detail Design Report
NASA Contractor Report 165558, 1982

[37] Haaland, Skjalg E
Simple and explicit formulas for the friction factor in turbulent pipe flow
Journal of Fluids Engineering 105.1: 89-90, 1983

[38] Coppage, J. E.; Dallenbach, F
Study of supersonic radial compressors for refrigeration and pressurization systems
GARRETT CORP LOS ANGELES CA AIRESEARCH MFG DIV, 1956

[39] Japikse, David
Centrifugal Compressor Design and Performance
Concepts ETI, Inc, 1996

[40] KANG, Jeong-Seek; CHO, Sung-Kook; KANG, Shin-Hyoung
Development of a performance prediction method for centrifugal compressor channel diffusers
KSME international journal, 16. Jg., Nr. 8, S. 1144-1153, 2002

[41] TRAUPEL, Walter
Die Theorie der Strömung durch Radialmaschinen
G. Braun, 1962.

[42] Müller, G., K. Vogt, and B. Ponick.
Berechnung elektrischer Maschinen
Wiley 2008

[43] D. Schröder and R. Marquardt.
Leistungselektronische Schaltungen : Funktion, Auslegung und Anwendung
Springer 2019

[44] P. C. Vratny.
Conceptual Design Methods of Electric Power Architectures for Hybrid Energy Aircraft
TU München 2019

[45] A. Wintrich et al.
Application Manual Power Semiconductors
Semikron 2015

[46] G. Pellegrino et al.
Comparison of Induction and PM Synchronous Motor Drives for EV Application Including Design Examples
IEEE Transactions on Industry Applications, vol. 48, no. 6, pp. 2322-2332, 2012



Index

- A -

A9/A8 Schedule 45
 Abbreviations 294
 Acceleration 133
 Accuracy of Engine Test Analysis 57
 Adaptive Random Search 226, 269
 Additions to the Standard Off-Design Iteration Scheme 241
 Advance Ratio 186
 Aerodynamic Design 200
 Aerodynamic Interface Plane 157
 Afterburner 44, 70, 179
 Design Inlet Mach No. 180
 Dimensions 222
 Efficiency 180
 Equivalent Dry Nozzle Area 179
 Limiters 179
 Operating Line 88
 Pressure Loss 180
 Specify Thrust 179
 Thermodynamic Station 183
 Air System 37, 184
 Relative Enthalpy Rise 302
 Aircraft Performance 284
 Airspeed 300
 Altitude Test Facility 156
 Ambient Conditions 39
 AN² 173
 Analysis by Synthesis 31, 100
 Compressor 101
 Annulus
 Burner, Duct, Exhaust 66
 Compressor 63
 Shape Descriptor 197
 Turbine 65
 AnSyn 31, 100
 AnSyn Factor 104, 303
 Approach Idle 124, 128
 APU 59
 Aspect Ratio 197
 Assumed Temperature 127
 Asymmetric Distribution 266
 Atmosphere 144
 Augmentor 44, 179
 Automatic Bleed 24, 113

Autopilot 128
 Auxiliary Coordinate Beta 190
 Auxiliary Power Unit 59
 Average in a Mission 89
 Axial Compressor
 Blade and Vane Numbers 197
 Dimensions 197
 Shape Descriptor 197
 Axial Compressor Design Example 199
 Axial Compressor Efficiency 200

- B -

Background Picture 194
 Basic Scope 7
 Batch Job 245
 Aircraft Performance 284
 Edit 245
 Example 245
 General 244
 Nomenclature 244
 Run 246
 Bearing Support 196, 220, 221
 Beta, Auxilliary Coordinate in Maps 190
 Bitmap 194
 Blade and Vane Numbers
 Axial Compressor 197
 Blade Stress 173
 Blade Temperature 172
 Bleed
 Automatic 24
 Recirculating 160
 Bleed Port Selection 242
 Boosted Turbohaft
 Iteration Setup 260
 Booster
 Design Example 197
 Booster Map Type 188
 Boundaries 50
 Burner 137, 167, 170, 171
 DesignExample 217
 Dimensions 216
 Emissions 170
 Heat Soakage 133
 Mass (Weight) 216
 Off-Design Efficiency 81
 Part Load Constant 167
 Temperature Rise 167
 Time Constant 137
 Volume 216
 Burst Margin 228



Burst Speed 228
Bypass 221
 Heat Exchanger 167

- C -

Calculation Time
 Composed Values 287

Calibrated Airspeed 300

Calibrating a Model 96

Can Volume 216

Capacity
 Compressor 84
 Turbine 302

Catalog 250

Celsius 13

Centrifugal Compressor 212

Chemical Composition
 Fuel 142

Clipboard 250

CO and UHC 171

Coarse Grid 247, 248

Cold Day 144

Colors
 Contour Lines 250

Combined Cycle 230
 HRSG Design 231
 Off-Design 232

Combustor 167, 170, 171
 Axial Flow Combustor 216
 CO and UHC 171
 Efficiency 167
 Emissions 170, 171
 NOx 170
 Part Load Constant 167
 Pressure Losses 170
 Reverse Flow Combustor 217
 Temperature Rise 167

Common Core 276

Comparative Data 104, 272, 274, 278
 File Format 96

Compare Data with GasTurb Results 108, 278
 Cycle Design Point 272
 Model Based Test Analysis 104
 Off Design Point 272, 274

Comparing Data with GasTurb 96

Compatibility of GasTurb 13
 Equivalent Shaft Power of a Turboprop 5
 GasTurb 10 7
 Inlet Flow Distortion 7
 Reynolds Number Index 7

 Secondary Air System 5

Compatibility with Previous GasTurb Versions 4

Compiling GasTurb 288

Component Map 191
 Compressor 187
 Fan 188, 189
 Format 145
 Intake 186
 Propeller 192

Composed Value
 Mission Average 89
 Mission Sum 89

Composed Values 10, 236, 238
 Calculation Time 287
 Functions 234, 237
 Introduction 10
 Tables 236
 User Defined Names 10

Compressor 158, 159, 237
 Axial Compressor Aerodynamic Loss 200
 Axial Compressor Design 200
 Axial Compressor Design Example 199
 Axial Compressor Optimization 200
 Calculation 158
 Capacity 84
 Design 157, 197
 Efficiency 40, 158
 Efficiency Estimate 159
 Efficiency Modifier 92
 Map 187, 188
 Map Format 146
 Map Scaling 72
 Size Effect on Efficiency 159
 Surge Margin 190
 Thermodynamic Station 183
 Tip Clearance 159
 Variable Geometry 274
 Water Injection 160, 161

Compressor Coupling 164

Compressor Design Example 199

Compressor Map
 Efficiency Distribution 273

Computer Deck 236, 298

Condition 242

Cone Angle 222

Cone Length 196, 221

Configuration 8

Constraints 55
 Off-Design 56

Contour Lines 50, 52, 250

- Control Schedules 118, 234
 - General Tables 236
- Control System
 - Automatic Bleed 113
 - Control Schedules 111
 - Engine Model 70
 - Limiter 22, 258, 259, 261
 - Limiter Codes (Steady State) 112
 - Limiter Codes (Transient) 133
 - Power Lever 133
 - Single Limiter 109
 - Transient 136
- Conventional Test Analysis 42
- Convergence 88, 255, 256
- Convergence Problems
 - Idle 124
 - Number of Restarts 251
 - While Calculating Rating Schedules 119
- Convergent Nozzle 45
 - Dimensions 222
 - Discharge Coefficient 181
- Convergent-Divergent Nozzle 45, 82
 - A9/A8 Schedule 45
 - Dimensions 222
 - Discharge Coefficient 181
- Cooled Turbine 175, 176
- Cooling Air Cooling 37
- Cooling Air Pumping Diameter 176
- Cooling Constant 172
- Cooling Effectiveness 172
- Cooling with Steam 143
- Copy to Clipboard 250
 - Overlay 51
- Core dP/P 155
- Core Efficiency 304, 305
- Core EPR 117
- Core Flow Analysis 103
- Corner Point Temperature 115
- Corrected Flow 299
- Corrected Speed 299
- Create Data File Example 104
- Creating a GasTurb Model 278
- Critical Sector Angle 162
- Cross Cut 194
- Cross Section 194
- Cruise 128
- Customer Bleed 37
- Customer Bleed Port Selection 242
- Customer Deck 244
- Cycle Design Point 36, 272
- Cycle Output Sheet 9
- Cycle Reference Point 36, 272
- D -**
- Data Enrichment 97
- Data Export 242, 243, 246
- Data File 70, 293
- Deceleration 133
- Deck 298
- DECU 113
- Define Input Quantities 20, 81
- Degree of Reheat 170
- Delta Compressor Efficiency
 - Constant Pressure Ratio 251
 - Constant Specific Work 251
- Denver Bump 126
- De-Rating 126, 127
- Derivative Engine 276
- Design Margin
 - Disks 226
- Design Point 36
- Design Point Input
 - Basic Data 36
 - Compressor Efficiency 40
 - Con-Di Nozzle 45
 - Convergent Nozzle 45
 - Mass Flow 40
 - Reheat 44
 - Test Analysis 42
 - Turbine Efficiency 41
- Design Table 26, 89
- Deterioration 84
- Development Risk 56
- Diagram 287
 - Enthalpy-Entropy 287
 - Temperature-Entropy 287
- Diesel 142
- Difference between 2 Parametric Studies 53
- Differential Control Constant 136
- Diffusor
 - Burner Inlet 197, 216
- Dimensions
 - Axial Compressor 197
 - Burner 216
 - Burner, Duct, Exhaust 66
 - Compressor Annulus 63
 - Exhaust Duct 221
 - Inlet 196
 - Intercooler and Heat Exchanger 224
 - Interduct 220



- Dimensions
 - Nozzle, Exhaust 222
 - Reheat (Afterburner) 222
 - Turbine 218
 - Turbine Annulus 65
- Discharge Coefficient 181, 222
- Disk 225
 - Dead and Live Weight 225
 - Design 66
 - Design Criteria 228
 - Design Options 226
 - Design Speed 225
 - Geometry 225
 - Temperature 226
- Dissociation 142, 167
- Distortion 162
 - Aerodynamic Interface Plane 157
 - Input 83
 - Pressure 164
 - Temperature 165
- DLL 236, 298
- Duct Pressure Loss 165
- Dynamic Link Library 298
- E -**
- Economizer 231
- Edit
 - Batch job 245
 - Range Checking Borders 234
- EEC 113
- Effective Burning Area 180
- Effectiveness 303
 - HRSG 232
- Effects
 - Design 56
 - Getting Started 19
 - Off Design 27, 92
- Efficiency 305
 - Combustor 167
 - Compressor 40, 159
 - Compressor Map 273
 - Core 304, 305
 - Exergetic 301
 - Gearbox 165
 - Ideal Propeller 184
 - Modifier 84, 92
 - Overall 305
 - Peak Efficiency 306
 - Peak Efficiency (Map Scaling) 74
 - Propulsive 304, 305
 - Real Propeller 186
 - Reheat 180
 - Thermal 304, 305
 - Transmission 305
 - Turbine 41
- EGT Margin 116, 120
- Emissions 143, 170
 - CO and UHC 171
 - NOx 170
- Enable Geometry 62
- Endless Random Search 269
- Engine Design for Supersonic Flight 284
- Engine Design Uncertainty 56
- Engine Dimensions
 - Burner, Duct, Exhaust 66
 - Compressor Annulus 63
 - Disk Design 66
 - Overview 62
 - Turbine Annulus 65
- Engine Family 276
- Engine Model 70
- Engine Pressure Ratio 117
- Engine Type 8
- Enthalpy 142
- Enthalpy-Entropy Diagram 287
- Entropy 142, 300
- Entropy Function
 - Compression 158
 - Definition 300
 - Uncooled Turbine 175
- EPR 117
- Equivalent Dry Nozzle Area 179, 181
- Equivalent Shaft Power 302
- Equivalent Single Stage Turbine 174
- Equivalent Airspeed 300
- Estimated Values 83
- Evaporation Rate 160
- Evaporative Inlet Cooling 143
- Evaporator 231
- Excel
 - Export Data to 242, 246
 - Test Analysis Results 109
- Exergetic Efficiency 301
- Exergy 301
- Exhaust (Nozzle)
 - Dimensions 222
- Exhaust Duct 177
 - Dimensions 221
- Exhaust Gas Temperature 116
- Exhaust Loss 177
- Exhaust Pressure Loss

Exhaust Pressure Loss
 Power Generation 157
 Exit Swirl 177
 Expert Mode 7
 Export
 Copy and Paste 9
 Graphics 250
 Mission Calculation Results 92
 Mission Data to File 26
 to Excel 242, 246
 User Defined File Content 243
 External Load 58

- F -

FADEC 113
 Fahrenheit 13
 Fan
 Design Example 197
 Exit Guide Vane 196
 Map 188
 Map for Single Stage Fan 189
 Map Scaling 77
 Pressure Ratio 280
 FHV 36
 Fighter Engines
 Control 113
 Figure of Merit 56
 File Extensions 293
 File History 70
 File Names 293
 Fine Grid 247, 248
 Flat Rate Temperature 115
 Flat Rating
 at Altitude 115
 at Sea Level 115
 FLEX Temperature 127
 Flight Envelope 93, 118
 Getting Started 28
 Flight Idle 128
 Flight Input Mode 155
 Flight Mission 26, 89
 Flow Annulus
 Burner, Duct, Exhaust 66
 Compressor 63
 Turbine 65
 Flow Capacity 302
 Flow Channel
 Burner, Duct, Exhaust 66
 Compressor 63
 Turbine 65

Fogging 143
 Fuel 36, 142
 Fuel Flow
 Run to a Given Value 278
 Fuel Type
 Parametric Study 13
 Fully Rated 113
 Functions 237
 Fundamental Pressure Loss 180

- G -

Gamma 237
 Gap-Chord Ratio 197
 Gas Constant 142
 Gas Properties 142, 237
 Humidity 142
 GasTurb DLL 236
 GasTurb Names 293
 Gaussian Distribution 264
 Gearbox 165, 224
 Geared Turbofan 262
 Iteration Setup 262
 Transient 262
 General 54, 184
 General Error 288
 General Tables 236
 As Control Schedules 111
 Generic Fuel 142
 Genetic Algorithm 269
 Getting Help 3
 Gradient Search 267
 Graphics 247, 248
 Copy to Clipboard 250
 Grid Options 247, 248
 Picture Catalog 250
 Scales 247, 248
 Several y-Axis 248
 Single y-Axis 247
 Zoom 247, 248
 Ground Idle 124, 128
 Ground Input Mode 155
 Ground Vehicle Propulsion 167

- H -

Handling Bleed 37, 113
 Automatic 24
 Heat Exchange
 Effectiveness 303
 Heat Exchanger
 Bypass 167



Heat Exchanger
Simulation Options 166

Heat Rate 298

Heat Recovery Steam Generator 230
Combined Cycle 230
Design 231
Effectiveness 232
Off-Design Constant 232
Pinch Point 231, 232
Single Pressure 230

Heat Soakage 131
Burner 133
Compressors and Turbines 132

Heating Value 142

Help 3

History 70

Hot Day 144

Hot Day Take-Off 56

How to 272, 273, 274, 276, 278, 279, 280, 281, 282, 283, 284, 288

HRSG 230
Single Pressure 230

HRSG Design 231

HRSG Off-Design 232

Humidity
Effect on Corrected Spool Speed Limiters 109

Hybrid Test Data 97

Hydrogen 142

- | -

Ideal Jet Velocity Ratio 280

Ideal Power Coefficient
Propeller 184

Ideal Thrust Coefficient
Nozzle 183
Propeller 184

Idle 22, 111, 118, 124, 128

Idle Schedule 119

IGV 21

Imperial Units 13, 296

Incidence Loss Constant 177

Increment 225

Indicated Airspeed 300

Indirect Test Data 97

Initialize Transient 28

Inlet
Dimensions 196
Flow Distortion 162
Pressure Loss (Power Generation) 155, 157

Inlet Guide Vanes (variable) 21

Inlet Swirl to Exhaust Guide Vanes 178

Input Data
Enhanced Transient Model 138
Off-Design 20
Steady State 81
Transient 136

Input Errors 234

Input Parameter 234, 238

Installation 2
Data Directory 2
Map Directory 2
Network 2
Working Directory 2

Intake 143, 155, 156
Distortion 83
Fogging 143
Map 186
Pressure Distortion 164
Pressure Loss 155
Radial Distortion 155
Radial Pressure Loss Distribution 155
Temperature Distortion 165

Intake Map Format 146

Integral Control Constant 136

Integrated EPR 117

Intercooler 166

Interduct
Dimensions 220
Pressure Loss 165
Pressure Loss in an Interturbine Duct 177

Internal Air System 37, 184
Relative Enthalpy Rise 302
Test Analysis 103

Interpolation Options 251

Interstage Bleed 37, 302

Introduction to GasTurb 2

ISA 144, 298

ISA Correction 106

Iteration 260
Boosted Turboshaft 260
Convergence 88, 255, 256
Design 241
GearedTurbofan 262
Introduction 12
Mixed Flow Turbofan 262
Newton Raphson 254, 255
Off-Design 241
Single Spool Turbojet 258
Transient 254
Turboprop 259, 260

- Iteration 260
 - Unmixed Flow Turbofan 261
 - Variable Cycle Engine 263
- Iteration Target 234, 236, 238
- Iteration Variable 83
- J -**
- Jacobi Matrix 254, 255
- Jet Velocity Ratio 280
- JP-10 142
- JP-4 142
- K -**
- Kelvin 13
- Kerosen 142
- Key 145
- Kink Point Temperature
 - at Altitude 115
 - at Sea Level 115
- L -**
- Layout File 90
- Lift Fan 58
- Limiter 22, 234
 - Effect of Humidity 109
 - General Table 236
 - Interaction of Min and Max Limiters 109
 - Interaction with Iteration Setup 82
 - Limiter Codes (Steady State) 112
 - Limiter Codes (Transient) 133
 - Mission 26, 89
 - Schedules 111
 - Shaft Power or Fuel Flow 259
 - Single Limiter Setting 109
 - Temperature Control Schedule 281
 - Thrust or Fuel Flow 258, 261
- Limiters 109
 - Power Manegment 125
- Load Compressor 59
- Long Names 296
- Low Idle 124, 128
- M -**
- Manufacturing Tolerance 99
- Map 71, 72, 77, 187, 188, 189, 191, 275
 - Intake 186
 - Propeller 153, 192
 - Re-Labeling the Speed Lines 274
 - Turbine 154
- Map Directory 2
- Map Format 145
- Map Reference Speed 76
- Map Scaling 70, 76
 - Compressor Map 72
 - Efficiency 74
 - Example 1 75
 - Example 2 76
 - Map Scaling File 71
 - Parametric Study 275
 - Procedure 71
 - Single Stage Fan 77
 - Turbine 80
 - Writing Scaled Maps to File 244
- Map Scaling Point 71, 72, 74, 75, 77
- Map Type 188
- Mass
 - Axial Compressor 197
 - Burner 216
 - Disk 226
 - Gearbox 224
 - Inlet 196
 - Inter-duct 220
 - Turbine 218
- Mass Flow Input 40
- Matching a GasTurb Model to Given Data 272, 273, 274, 278
- Max Climb 118, 128
- Max Climb Rating Schedule 123
- Max Continuous 118
- Max Continuous Rating Schedule 122
- Max Cruise 118
- Max Limiter 109, 111
- Maximum Limiter 22
- Measured Data 96
- Measurement Tolerance 107
- Metal Temperature 172
- MIL 210 144
- Min Limiter 109
- Min Limiter Settings 124
- Min Limiters 119
- Minimum Limter 22
- Mission 26
 - Export of Results 92
 - Layout of Output List 90
 - Mission Average 89
 - Mission Sum 89
 - Optimization Constraints 56
 - Output=Input 91
- Mixed Flow Turbofan
 - Fan and Booster Map 188
 - Iteration Setup 262



Mixer 179
 General 222

Model Based Test Analysis 31

Modifiers 84

Monitoring 31
 Iteration 256

Monte Carlo 56, 265
 Algorithm 264
 Asymmetric Distribution 266
 Confidence 282
 Development Risk 56
 Input 265
 Manufacturing Tolerance 99
 Off-Design 28, 99
 Standard Deviation 265
 Test Analysis Uncertainty 17
 Trapezoid Distribution 266

More (Scope) 7

More Than Performance 32

Multiple Operating Lines 25

- N -

Names 296

Natural Gas 142

Newton Raphson 254, 255

NGV 298

NMS Files 293

Nomenclature 293
 Air System 37
 General 292
 Stations 293
 Symbols 294

Nominal Speed 299

Normal Distribution 264

Novice Mode 7

NOx 143, 170

Nozzle 45, 181, 237
 C/D Area Schedule 82
 Convergent 181
 Convergent-Divergent 181
 Dimensions 222
 Petal Angle 181
 Plug Nozzle 222
 Standard Nozzle 222
 Thrust Coefficient 183

Nozzle Calculation Switch 46, 181

Nozzle Guide Vane 298

Number of Restarts 251

- O -

OAT 115

Off-Design 236, 272, 274
 Disk Stress 62
 Effects 27
 General Remarks 70
 Getting Started 20
 Input Data 20
 Parametric Study 26, 86, 88

Off-Design Input Data 82
 C/D Nozzle Area Schedule 82
 Flow Distortion 83
 Iteration Variable 83
 Modifiers 84
 T4 Input 82
 Tip Clearance Correction 84
 Variable Geometry (Compressor) 85
 ZNX input 82

Operating Line 24, 86
 Compare with Given Data 96
 Multiple Operating Lines 25
 Reheat 24, 88
 Single Spool Turboshaft 87

Optimization
 Adaptive Random Search 269
 Algorithms 266
 Constraints 55
 Figure of Merit 56
 General 54
 Getting Started 15
 Gradient Search 267
 Off-Design Constraints 56
 Variables 55

Optimizing Disk Dimensions 66, 226

Options
 Temperature Units 251

Outer Air Temperature OAT 115

Output
 Export to Excel 242, 246
 Test Analysis Results 108
 Text File 243

Output=Input 91

Overall Efficiency 305

Overboard Bleed 37

Overlay 51

Overspray 143

Overstressed Disk 228

- P -

Parallel Compressor Theory
 Aerodynamic Interface Plane 162
 Compressor Coupling 164

Parametric Study 13, 238

- Parametric Study 13, 238
 - Contour Lines 250
 - Difference between 2 Study Results 53
 - General 47
 - Map Scaling 275
 - Off Design 88
 - Off-Design 26, 86
 - Picture Catalog 250
 - with Contour Lines for Off-Design 52
 - with Iteration 48
 - Partload 128
 - Peak Efficiency 74, 306
 - Performance Scope 7
 - Petal Angle 181, 222
 - Picture Catalog 250
 - PID Control 136
 - Pinch Point 230, 231
 - Pipe Flow Analogy 150
 - Pipe Flow Analogy Application 152
 - Pipe Flow Analogy Variations 153
 - Pitch-Chord Ratio 197
 - PLA 118, 120, 133
 - Plug Nozzle 222
 - POT and Bleed Input=f(Time) 138
 - Power Coefficient 186
 - Power Generation 87
 - Inlet and Exhaust Pressure Loss 157
 - Input Mode 155
 - Power Lever 28, 118, 133
 - Use for Power Management 125
 - Power Lever Angle 120
 - Power Lever Input = f(Time) 138
 - Power Mangement 125
 - Power Offtake
 - From Any Spool 58
 - Transient 137
 - Pre-Defined Functions 237
 - Preliminary Engine Design 7
 - Pressure 297
 - Pressure Loss 180
 - Burner 170
 - Compressor Interduct. 165
 - Exhaust Duct 177
 - Exhaust Guide Vane 178
 - Fundamental Pressure Loss 180
 - Inlet 157
 - Intake 155
 - Reheat, Afterburner 180
 - Turbine Inter-duct 177
 - Production Scatter 99
 - Program Directory 2
 - Propeller 153
 - General 184
 - Ideal 184
 - Map 192
 - Map Format 153
 - Real 186
 - Static Performance 153
 - Proportional Control Constant 136
 - Propulsive Efficiency 304, 305
 - Pumping Diameter 176
- R -**
- Radial Compressor 212
 - Aerodynamic Design 212
 - Geometry Nomenclature 214
 - Two Stage Design 216
 - Radial Pressure Profile 155
 - Rain 283
 - Range Checking 234
 - Rankine 13
 - Rating Adjustment
 - Bleed 126
 - De-Rating 126
 - Rating Adjustments
 - Idle 128
 - Rating Availability 118
 - Rating Schedule 125
 - Rating Schedules
 - Limiter Settings 119
 - Rayleigh Line 170, 180
 - Recirculation Bleed 160
 - Recuperator 166
 - Red Line Temperature 116
 - Reference Point 36
 - References 310
 - Regenerator 166
 - Reheat 44, 70, 179
 - Design Inlet Mach No. 180
 - Dimensions 222
 - Efficiency 180
 - Equivalent Dry Nozzle Area 179
 - Limiters 179
 - Operating Line 88
 - Partload 24
 - Pressure Loss 180
 - Sequential Combustion 170
 - Specify Thrust 179
 - Thermodynamic Station 183
 - Re-Labeling Speed Lines 274



Relative Enthalpy Rise 302
Relative Speed 299
Relative Tip Clearance 40
Restart Iteration 251
Reverse Flow Combustor
 Design Example 217
Reynolds Correction 74
 General 148
 How to Modify 279
 Map Scaling Example 75
 Pipe Flow Analogy 150
 Pipe Flow Analogy Application 152
 Pipe Flow Analogy Variations 153
 Reynolds Number Index 150
Reynolds number 150
Reynolds Number Index
 Definition 148
Risk Prediction 56
RIT 298
RNI 150
 Calculation 148
Root-Sum-Squared 264
Rotor Inlet Temperature 175, 298
Running Line 24

- S -

Scales of Graphs 247, 248
Scaling Factor 31
Scan Sequence Number 104
ScanId 104
Schedule
 Nozzle Area 281
 Turbine Temperature 281
Schedule Correction 107
Schedules 111
Scope 7
 More 32
Secondary Air System 37, 184
 Relative Enthalpy Rise 302
Sensor Checking 105
Sensor Time Constant inTransient 137
Sequential Combustion 170
Shaft 225
Short Names 296
Shrouded Blades 218
SI Units 296
Single Cycle Output 9
Single Point Mission 89
Single Spool Turbojet
 Iteration Setup 258

Single Spool Turboshaft
 Limiter Interaction with Iteration Setup 82
 Operating Line 87
Single Stage Fan Map 189
Small Effects
 Design 56
 Getting Started 19
 Off Design 92
Smooth C 146, 154
Smooth T 154
SOT 175, 176, 298
Special Maps 71, 72, 76, 77
Specific Fuel Consumption 304, 305
Specific Heat 142
Specify Shaft Power or Fuel Flow 259
Specify Thrust or Fuel Flow 22, 258, 261
Speed
 Aircraft 300
 Spool 299
Split Map 188
Splitter 196
Stability Assessment 162, 164
Standard Atmosphere 144
Standard Correction 106
Standard Data Directory 2
Standard Data Files 70
Standard Day 298
Standard Day Corrected 299
Standard Deviation 265
Standard Map 71
Static Pressure 297
Static Propeller Thrust 186, 192
Static Temperature 297
Station 183, 293
 Input and Results 46
 Thermodynamic 183
Statistical Background 264
Stator Outlet Temperature 175, 176, 298
Steady State Engine Control 109
Steady State Input Data 81
Steam Cooling 143
Steam Generation 230
Steam Injection 143
Steam Turbine 232
Strategy in Optimization 266
Stress Margin 228
Sum in over a Mission 89
Superheater 231
Supersonic Engine Design 284

- Surge Margin 190, 279
 - Inlet Flow Distortion 162
 - Small Effects 27
- Switching Units 13
- Symbols 294
- T -**
- T41 298
- T41 Limiter Setting = $f(\text{Altitude})$ 123
- Tables 145, 236
 - Editor 236
 - Format 145
 - General 236
 - Key 145
- Take Off 118
- Take Off Rating Schedules 120
- Tapezoid Distribution 266
- Target
 - Design Point Iteration 241
 - Off-Design Iteration 241
- Temperature 297
 - Disk 226
- Temperature-Entropy Diagram 287
- Test Analysis 43, 102, 107, 108, 109, 303
 - Air System 103
 - Altitude Test Facility 156
 - Analysis by Synthesis 100
 - Comparison with a Model 108
 - Compressor AnSyn 101
 - Conventional 43
 - Data Input Overview 102
 - Deviations from Model 104
 - Effect of Measurement Errors 107
 - Example 43
 - Export of Data 108
 - Export to Excel 109
 - Flow Analysis Method 103
 - ISA Correction 108, 109
 - Measured Values 102
 - Monte Carlo Study 99
 - Multiple Point Data Input 104
 - Rated Power 107
 - Schedule Correction 107, 108, 109
 - Sensor Checking 105
 - Standard Correction 106
 - Test Analysis by Synthesis 31
 - Transient 283
 - Turbine Capacity 103
 - Turbojet 100
 - Turboshaft 101
 - Uncertainty 57
 - with Design Calculation 42
- Test Bed 156
- Test Data 96
- Test Data Enrichment 97
- Test Data File Format 96
- Test Data Input 102
- Testbed Input Mode 155
- Thermal Efficiency 304, 305
- Thermodynamic Station 46, 183
- Thermodynamic Turbine Efficiency 41, 176
- Throttle Lever 118
- Throttle Lever Angle 114
- Throttle Lever Dead Band 113
- Thrust
 - Run to a Given Value 278
 - Static 186, 192
- Thrust Coefficient
 - Ideal Propeller 184
 - Nozzle 183
- Thrust Management 113, 118, 125
 - Subsonic Airliners 114
- Thrust Rating 113, 114
- Thrust Setting Parameter 117
- Time Constant 137
 - Heat Soakage 131
 - Transient 131
- Tip Clearance
 - Compressor Efficiency 40
 - Input 138
 - Off-Design 84
 - Transient 130
 - Turbine Design 173
- TLA 118
- Total Pressure 297
- Total Temperature 297
- Transient 138, 139
 - 100% Power Offtake 137
 - Accel and Decel 133
 - Burner Time Constant 137
 - Compressor and Turbine Heat Soakage 132
 - Enhanced Model 129
 - Fuel Flow Input 139
 - Geared Turbofan Iteration Setup 262
 - General 128
 - Heat Soakage 131
 - Initialize 28
 - Input Data 136
 - Iteration Variables 139
 - Iteration Variables and Errors 139
 - Limiter Codes 133



Transient 138, 139
 PID Control 136
 POT and Bleed Input=f(Time) 138
 Power Lever 133
 Power Lever Input = f(Time) 138
 Running the Enhanced Model 140
 Running the Simplified Model 139
 Scope 128, 129
 Simplified Model 128
 Spool Speed Input 139
 Temp Sensor Time Constant 137
 Time Constant 131
 Time Step 139
 Tip Clearance 130, 140
Transmission Efficiency 305
True Airspeed 300
TST File 97
TST File Format 96
Turbine 172, 237
 Blade Metal Temperature 172
 Cooled 175, 176
 Cooling Constant 172
 Design 171, 172
 Dimensions 218
 Efficiency 41
 Flow Capacity 103, 302
 General 174
 HP Turbine Design Example 218
 Inter-duct 177
 LP Turbine Design Examples 219
 Map 154, 191
 Map Scaling 80
 Thermodynamic Station 183
 Tip Clearance Correction 173
 Uncooled 175
Turbine Exhaust Duct 177
Turbofan 280, 304
 Booster Map 280
 Core Efficiency 304
 Handling Bleed Location 37
 Mixed Flow 280
 Propulsive Efficiency 304
 Transmission Efficiency 304
 Unmixed Flow 280
 Water Injection 283
Turbojet
 Test Analysis 100
Turboprop
 Equivalent Shaft Power 302
 Iteration 260
 Single Spool 87

Turboshaft
 Exhaust Duct Loss 177
 Single Spool 87
 Test Analysis 101
Tutorial 7
Two Spool Turboshaft & Turboprop
 Iteration Setup 259

- U -

Units 234
Units Converter 296
Unmixed Flow Turbofan
 Iteration Setup 261
Un-Scaled Maps 76
Unshrouded Blades 218
US Units 296
User Defined Iteration 241
User Defined Names 10

- V -

Variable
 Design Point Iteration 241
 Off-Design Iteration 241
Variable Cycle Engine 287
 Bypass 221
 Iteration Setup 263
Variable Geometry 84
 Compressor 21, 85, 274
Variable Guide Vanes
 Single Spool Turboshaft 87
Vehicle Propulsion 167
Velocity Ratio 280
VGV 21, 85

- W -

Warnings 234
Water
 Gaseous 142, 143, 160, 283
 Liquid 161
Water Injection 160
 Combustor 143
 Compressor 160
 Evaporation Rate 160
 Fogging 143
 Turbofan 283
 Work Done on Liquid Water 161
Weight
 Axial Compressor 197
 Burner 216
 Disk 226
 Gearbox 224

Weight
 Inlet 196
 Inter-duct 220
 Turbine 218
Wet Compression 160
 Work Done on Liquid Water 161
What's New 4
Windows Metafile 250
Within Limits 109
Working Directory 2
Working Line 86
Write to Excel 242, 246
Write to File 243

- Z -

Zoom 247, 248
Z_{XN} 82
Z_{XN} given (1) or Z_{T4} given (2) 20

